

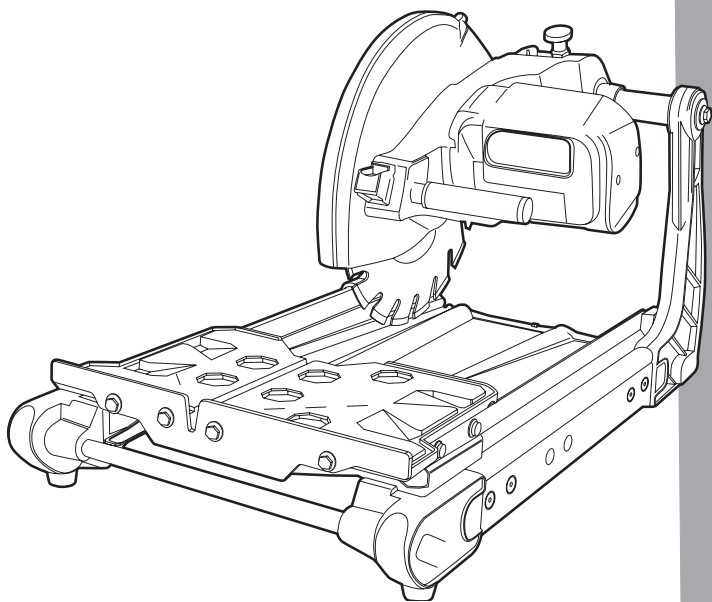

**OWNER'S MANUAL  
VX141MS - MASONRY SAW**



**PEARL ABRASIVE CO. - VX141MS MASONRY SAW**

***Before operating the unit, please read this manual thoroughly, and retain it for future reference.***

# TABLE OF CONTENTS

	◆ Page
<b>Contents</b> .....	<b>1</b>
<b>Safety Precautions</b> .....	<b>2</b>
<b>General Safety Rules</b> .....	<b>3</b>
<b>Health Warnings</b> .....	<b>3</b>
<b>Unpack, Assembly &amp; Set-up</b> .....	<b>4</b>
<b>Inspection &amp; Specification</b> .....	<b>5</b>
<b>Features</b> .....	<b>6</b>
<b>Cutting Table Assembly</b> .....	<b>7</b>
<b>The Rip Guide</b> .....	<b>8</b>
<b>Cutting Depth</b> .....	<b>8</b>
<b>Spring Lock Pin</b> .....	<b>9</b>
<b>Carbon Brush Replacement</b> .....	<b>10</b>
<b>Air Filter Replacement</b> .....	<b>11</b>
<b>Electric Motor Specification</b> .....	<b>12</b>
<b>Do's and Don't's for Blades</b> .....	<b>13</b>
<b>Saw Maintenance</b> .....	<b>15</b>
<b>Optional Accessories</b>	
<b>Angle Guide</b> .....	<b>17</b>
<b>Master Guide</b> .....	<b>17</b>
<b>Folding Stand</b> .....	<b>17</b>
<b>Folding Stand Assembly</b> .....	<b>18</b>
<b>Water Kit</b> .....	<b>18</b>
<b>Troubleshooting</b> .....	<b>19</b>
<b>Customer Service</b> .....	<b>22</b>
<b>Replacement Parts List</b> .....	<b>23</b>
<b>Exploded View</b> .....	<b>25</b>
<b>Contact Us</b> .....	<b>27</b>

# SAFETY PRECAUTIONS

Saw blade should be inspected daily for excessive wear, core cracks, and arbor damage. Replace any blade that shows signs of damage.

- To mount blade, clean arbor and outer flanges, tightening nut securely.
- **DO NOT** place any portion of body in line with blade while it is rotating.
- To reduce risk of electrical shock, it is recommended to use GFCI and refer servicing to qualified professional.

SawMaster recommends the use of these Safety Items when Operating the Saw:



**WEAR HEARING PROTECTION**



**WEAR EYE PROTECTION**



**USE BLADE GUARD WHEN OPERATING SAW**



**WEAR BREATHING PROTECTION**

## GENERAL SAFETY RULES

- Never use the machine improperly or work in an unsafe manner.
- Always wear safety goggles, dust mask, and ear protection while operating the saw (to comply with ANSI-Z87.1).
- Always remain alert when the saw is in use. Failure to pay attention on the operator's part may lead to serious injury.
- Before you start working, familiarize yourself with the work site and its surroundings. Take notice of circumstances which may impede working or traffic, observe soil conditions (good bearing or not), and take measures to ensure safety (i.e. the shielding of roadworks from public traffic).
- Take measures to ensure that the machine is in a safe and trouble-free condition prior to usage. Use the machine only when all protective devices (i.e. guards, noise absorbers, emergency-off devices) are operating in the intended locations.
- A visual check of the machine must be made at least once a shift to ensure that visible damages or faults are recognized. Any changes (including changes in the performance or behavior of the machine) must be reported to the supervisor. If necessary, stop the machine at once and secure it.
- In the case of a malfunction stop the machine immediately and secure it. Fix the problem as soon as possible.
- For starting and stopping the machine follow the operating instruction steps and observe any indicator lights.
- Before switching the machine on make sure that the activated machine will be of no danger to anyone.
- Be sure to connect the plug to a properly grounded receptacle to reduce the risk of electric shock.

## HEALTH WARNINGS:

Some dust are created by power sanding, sawing, grinding, drilling, and cause other construction activities contains chemicals known to cause cancer, birth defects or other reproductive harm. Some examples of these chemicals are:

- Lead from lead based paints,
- Crystalline silica from bricks and cement and other masonry products,
- Arsenic and chromium from chemically-treated lumber.

Your risk from these exposures varies, depending on how often you do this type of work. To reduce your exposure to these chemicals: work in a well ventilated are, and work with approved safety equipment, such as those dust masks that are specially designed to filter out microscopic particles.

# UNPACK, ASSEMBLY & SET-UP

Open the container, carefully lift the saw frame handles and place it on a flat, level working area. Be certain that you have the following items before you discard the container:

- Saw
- 45° /90° Rip Guide
- Universal Wrench
- Owner's Manual
- Extra Air Filter

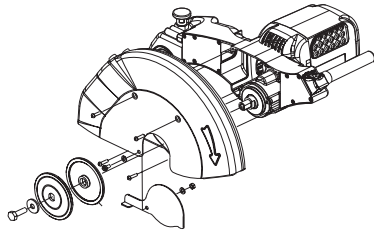

## Diamond Blade Installation

1. Move the blade shaft cover upwards. To remove the blade lock nut, open the shaft space.
2. Place the 14" blade onto the blade shaft. Make sure that the directional arrow is pointing in the direction of the shaft rotation.
3. Lock the blade lock nut with the outer flange. Use the multiple wrench provided to fasten the blade tightly.

# INSPECTIONS & SPECIFICATION

The compact VX141MS Masonry saws are shipped completely assembled and ready for use except for the diamond blade. Inspect the saw for shipping damage. If any damage is found, contact the shipper immediately and file a freight claim. Pearl is not responsible for any freight related damages. Remove the saw from the shipping container.

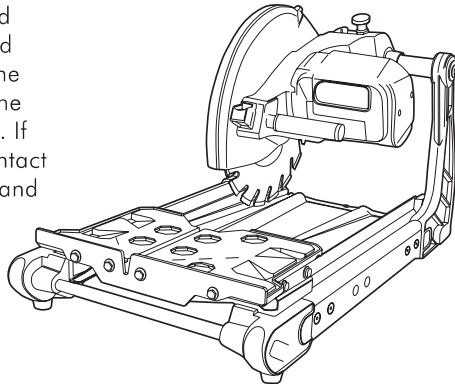

## VX141MS SPECIFICATIONS

<b>Horse Power</b>	<b>3 HP (2,238 kW) Peak</b>
<b>Volts</b>	<b>115 - volts</b>
<b>Amps</b>	<b>15 A</b>
<b>Hertz (Cycles)</b>	<b>60 Hz</b>
<b>Motor Type</b>	<b>Carbon Brush</b>
<b>Bearing Type</b>	<b>Heavy Duty Sealed</b>
<b>Blade Shaft Speed</b>	<b>3,600 rpm</b>
<b>Maximum Blade Size</b>	<b>14 (356mm)</b>
<b>Arbor Size</b>	<b>1" (25.4mm)</b>
<b>Maximum Depth of Cut</b>	<b>5" (127mm)</b>
<b>Straight Cut Length</b>	<b>17" (431mm)</b>
<b>Maximum Material Size</b>	<b>8" x 8" x 16"</b> <b>(203mm x 203mm x 406 mm)</b>
<b>Dimensions L x w x H</b>	<b>31-1/2" x 18-1/2" x 30"</b> <b>(800mm x 470mm x 762mm)</b>
<b>Weight Uncreated</b>	<b>75 lbs (34.1kg) Approx.</b>

# FEATURES

The VX141MS Masonry Saw is designed for the professional contractor in mind. It enhances performance with a multitude of features facilitating operation.

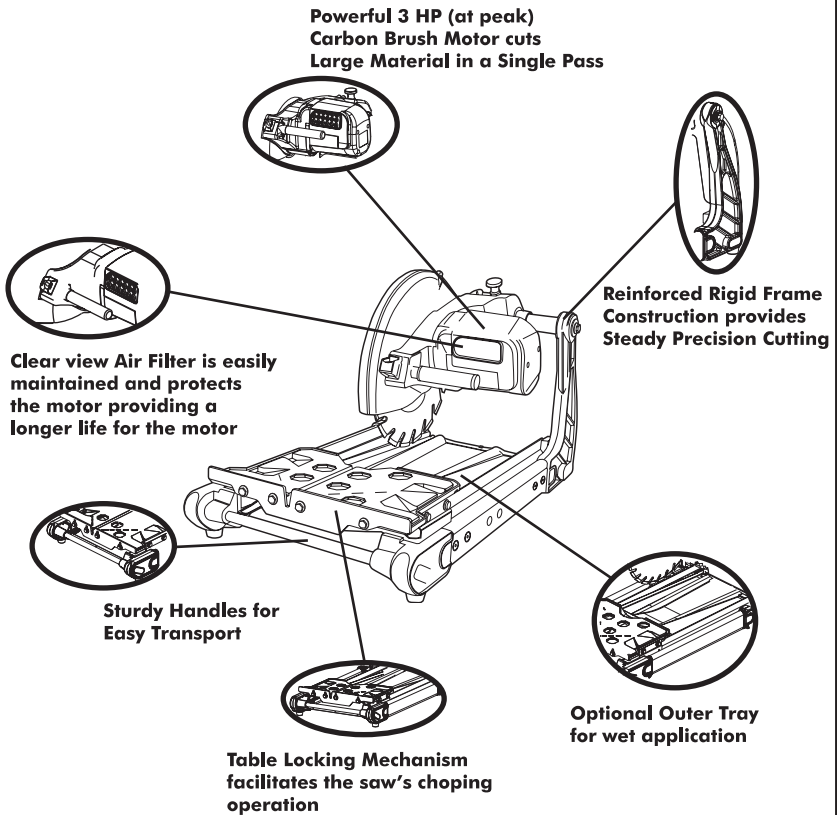

# CUTTING TABLE ASSEMBLY

To install the Cutting Table to the machine:

1. Set the Cutting Table on the rails.
2. Install the screws and brackets to the cutting table.
3. To remove the Cutting Table do the reverse of the above two steps.

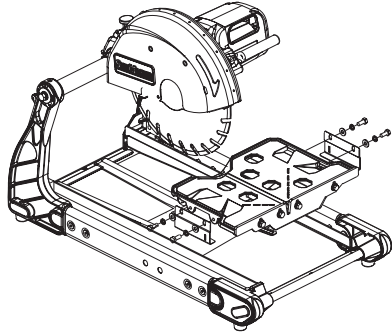

## THE CUTTING TABLE

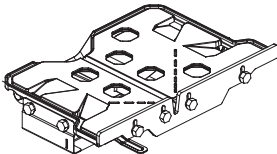

### Features:

- The heavy-duty cutting table with Steel Wheels provides the durability to handle large materials.

### **WARNING:**

Only use the **Ø14"** blade for this saw. Setting smaller size of diamond blade may grab the material being cut, causing damage and possibly injury.



# THE RIP GUIDE

## Steps to Use the 45° / 90° Rip Guide

1. Set the rip guide by positioning it on the desired dimension and tighten the threaded knob. Make sure that the rip guide is firmly tightened to avoid slippage. The rip guide can be used for 90° rip cuts and 45° angle cuts from both the left and right side. (Note the straight and 45° angled slits on the bottom of the rip guide.)
2. After the rip guide is positioned for the desired cut, place material flat against the rip guide and the measurement rail.

For 45° rip cuts, place the corner of material in the open slot of the measurement rail.

3. Simply line up the material being cut with the appropriate pre-marked lines on the cutting table.
4. Now you are ready to make your cut.

# CUTTING DEPTH

The recommended cutting depth is  $\frac{1}{4}$ " below the cutting table surface. The cutting clearance has been fixed from original designed.

**Blade Diameter**

**14"**

**Cutting Depth**

**5"**



### **WARNING:**

Only use the **Ø14"** blade for this saw. Setting smaller size of diamond blade may grab the material being cut, causing damage and possibly injury.

## THE SPRING LOCK PIN

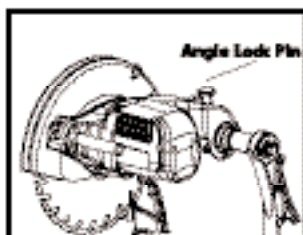

The VX141MS Masonry saw is designed with three different cutting heights for jam cutting, a moving head for chop (or plunge cutting), and a moving cart combined with the moving head for step cutting to help make any cutting task easier.

1. Before adjusting the cutting height always disconnect the electrical power supply.
2. To adjust the VX141MS's fixed cutting position, pull up on the Angle Lock Pin, move the head to the new position, release the Angle Lock Pin, and rotate the cutting head up/down until the Angle Lock Pin locks into position (lowest position for cutting thru bricks). The middle position is for cutting block and the upper position for blade replacement.

### Chop / Plunge Saw Operation

To operate the VX141MS as a chop or plunge saw: pull up on the Angle Lock Pin, rotate 90 degrees, and release. Now the cutting head can be rotated by pulling up or pushing down on the cutting head handle. When not in use, always lock the head into one of the three cutting height positions.

HEAD POSITION	APPLICATION
Fixed Lowest	Jam Cutting Bricks
Fixed Middle	Jam Cutting Block
Fixed Upper	Diamond Blade Replacement
Moving	Chop or Plunge Cutting
Moving Head with Moving Table	Step Cutting

## CARBON BRUSH REPLACEMENT

The VX141MS Masonry Saw uses a high horsepower low amperage air cooled brush motor. Replace the carbon brushes when the motor begins to lose power. Brushes typically need to be replaced during the life of the saw. Replace the brushes when over 2/3 of their original length is used (when the over all length of the brush is less than 7/16" (11.1mm). It is normal for the Brushes to wear down.

1. Disconnect the electrical supply.
2. Remove the Air Filter.
3. Remove the four (4) Motor Air In-Take Cover mounting screws (see Figure 4-1: Motor Air In-Take Cover Removal).
4. Remove the Motor Air In-Take from the motor.
5. Use a coin or wide blade screw driver to remove the Carbon Brush Cap. Use care not to damage the Carbon Brush Cap. Inspect the Cap for damage. If the Cap has any signs of damage replace (see Figure 4-2 Carbon Brush Removal).

Figure 4-2: Carbon Brush Removal

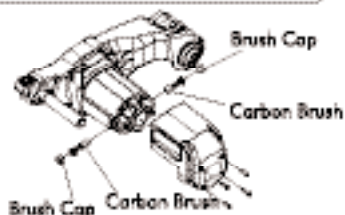

11. Reinstall the Motor Air In-Take Cover and re-attach the four mounting screws. Do not over tighten.
12. Clean the Air Filter.
13. Reinstall the Air Filter.

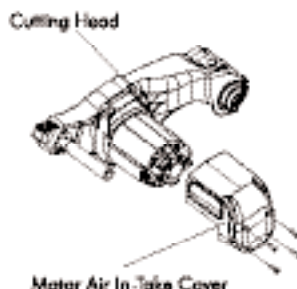
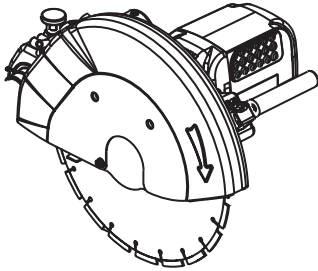

Figure 4-1: Motor Air In-Take Removal

6. Remove the Carbon Brush.
7. Use compressed air to blow any excess carbon build up out of the motor.
8. Rinspect the inside of the motor by looking into the brush holder for any excessive wear or carbon build up.
9. Place the new Carbon Brush into the Carbon Brush Holder.
10. Replace the Carbon Brush Cap and tighten the Cap with a coin or wide blade screw driver. Only snug the Cap down. Over tightening the Cap can cause damage to the Cap.

# AIR FILTER REPLACEMENT



The VX141MS Masonry saw is equipped with a specially designed air filter to help protect the motor from damage due to high speed dust intake during operation.

To replace the Air Filter:

1. Carefully remove the old Air Filter from the Motor Air In-Take Cover opening. **NOTE:** Pull the Air Filter thru the opening in the front of the Motor Air In-Take Cover.
2. Inspect the new Air Filter for damage.
3. Place the **NEW** Air Filter into the Motor Air In-Take Cover.
4. The Air Filter should fill the opening in the front of the Air In-Take Cover and should completely fill the filter cavity.

## **WARNING:**

Using the machine with a dirty, damaged, or missing Air Filter will result in motor damage and is not covered under warranty.

## Steps to Clean the Air Filter

To clean the Air Filter:

1. Carefully remove the Air Filter.
2. Clean the air filter by patting, and shaking the dust from the filter. It can also be cleaned with water. After clean dry before replacing to the air intake. Compressed air can be used to blow the dust out of the filter.
3. Inspect the filter for damage. Any damaged Air Filter must be replaced before using the machine.
4. Replace the filter into the Motor Air In-Take Cover.
5. Check to see if the Air Filter is installed properly. The Air Filter should fill the opening in the front of the Air In-Take Cover and should completely

# ELECTRIC MOTOR SPECIFICATION

## Features:

- Horsepower 3 H.P.
- Volts 115 V
- Amps 15 Amps
- Motor RPM 3600
- Cycle 60 Hz
- Watts 2238

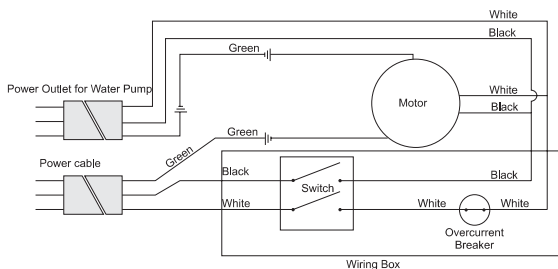
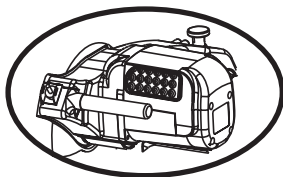

## Recommendations:

- It is recommended that a 15 AMP CIRCUIT be used while operating this saw. This will prevent any loss of power or interruption.
- Always plug saw as close as possible to the power source while operating. This will allow you to receive optimum electricity.

## WARNING:

To avoid permanent motor damage you must use the correct extension cord. Never use more than one extension cord at a time. Follow the chart for proper size:

WIRE GAUGE	LENGTH OF CORD 3 HP - 115 V
No. 10	25'
No. 8	50'
No. 6	75'

# DO'S & DON'TS FOR BLADES

## DO'S

- Inspect blades daily for cracks or uneven wear.
- Always use appropriate blade for material being cut.
- Inspect arbor shaft for uneven wear before mounting blade.
- Always use blades with the correct arbor shaft size.
- Ensure that blade is mounted in the correct direction.
- Secure the blade to the arbor with a wrench.
- Use proper safety equipment when operating the saw.
- Periodically check the blade for cracks or bond fatigue.

## DON'TS

- Do not operate the saw without safety guards in position.
- Do not operate the saw with blades larger than 14".
- Do not cut dry with blades marked "Use Wet".
- Do not exceed manufacturer's recommended maximum RPM.
- Do not force blade into material let blade cut at its own speed.

## DO'S

- In addition to the following, always follow wet recommendations.
- Use appropriate blade for material being cut.
- Inspect segment blades for segment cracking or loss.
- Do not use damaged blades.
- Use proper safety equipment when operating the saw.

## DON'TS

- In addition to the following, always follow wet recommendations.
- Do not make long cuts with dry blades-- allow them to air cool.
- Do not use the edge or side of blade to cut or grind.
- Do not attempt to cut a radius or curve.
- Do not cut too deep or too fast into the material.
- Do not cut any material not recommended by blade manufacturer.



## **WARNING:**

For your safety, before performing any maintenance on the saw turn off the power switch and unplug the power cord.

### **Cleaning**

---

#### **After every use of the machine:**

- Remove dirty water from container.

- Remove dirt and mud from the bottom of the container.

#### **After wet cleaning and before using the machine again:**

-Connect the machine to an electric power outlet equipped with a "GFCI" safety power breaker. If the safety power breaker cuts off the electrical power supply, do not try to operate the machine but have it checked by an authorized dealer first.

### **Before & After A Prolonged Time**

---

#### **After not using the machine for a prolonged period of time:**

-Clean and lubricate all movable parts.



- Check that the legs are safely fixed.
- Check that all screw joints and nuts are fixed.
- Check that the roller table is in its guides and that it easily moves to and fro.
- With the saw blade removed, switch on the motor for an instant and switch it off again. If the motor does not run, have the machine inspected by a qualified electrician.

# OPTIONAL ACCESSORIES

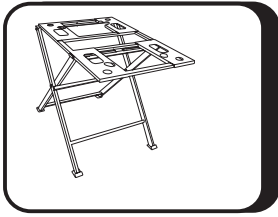

## **FOLDING STAND**

Part No. V350MS

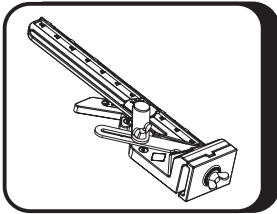

## **MASTER GUIDE**

Part No. V370064

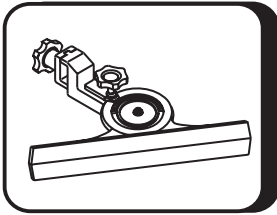

## **ANGLE GUIDE**

Part No. V370060

## OPTIONAL WATER KIT

Part No. V350MSWKIT

Includes:

Water Tub

Water Feed

Drip Tray

Drain Plug

Water Pump

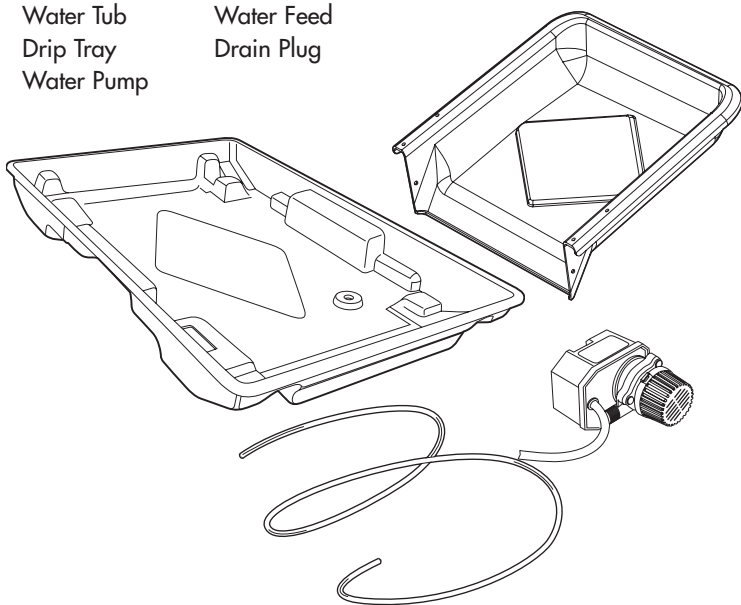

## OPTIONAL STAND ASSEMBLY

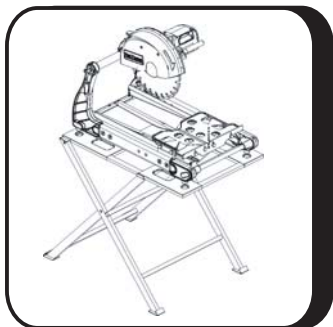

- 1.** Remove the folding stand from its box.
- 2.** Swing the working bench up-right. Open the two legs and place the workbench on top of the folding stand.
- 3.** After the saw stand is completely assembled, place the saw on top of the saw stand.

# TROUBLESHOOTING

<b>PROBLEM</b>	<b>POSSIBLE CAUSE</b>	<b>SOLUTION</b>
Machine does not run when switched on	- Power cord not properly fixed/plugged in	- Check that the machine is properly connected to the power supply
	- Power cord defective	- Have the power cord checked, replace if necessary
	- Main power switch defective	- Have the main power switch checked and replace if necessary by a qualified electrician
	- Loose electrical connection inside the electric system	- Have the whole electric system of the machine checked by a qualified electrician
Motor stops (power cut out)	- Motor defective	- Have the motor checked and replaced if necessary by a qualified technician
	- Too much pressure exerted while cutting	- Exert less pressure when cutting
	- Incorrect specification for saw blade	- Use a saw blade which corresponds to the material being cut
Poor machine performance little power	- Saw has a defective electric system	- Have the electric system of the saw checked by a qualified technician
	- Power cord/extension cable too long or cable still wound up inside cable drum	- Use a power cord/extension cable of the rated length, use a cable drum with cable fully extended
	- Power network is insufficient	- Observe the electrical ratings of the machine and connect it only to a power network which complies with these ratings

<b>PROBLEM</b>	<b>POSSIBLE CAUSE</b>	<b>SOLUTION</b>
	-Drive motor no longer runs at rated speed (r.p.m.)	- Have the motor checked by a qualified electrician and have it replaced if necessary
Irregular run of the saw blade	- Poor tension in the blade material	- Return the saw blade to the manufacturer
Saw blade wobbles when running	- Saw blade is damaged or bent	- Have the saw blade aligned/flattened - Clean the receiving flange
		- Solder the diamond segments of the old blade onto another saw blade or use a new blade
	- Flange of the saw blade is damaged Shaft of the motor is bent	- Replace the saw blade flange - Replace the electric Motor
Diamond segment becomes loose	- Overheating of the saw blade; cooling water not sufficient	- Have the diamond segment soldered on the blade again; ensure optimum flow of cooling water
Excessive wear	- Wrong type of saw blade - Shaft of motor causes wobbling - Overheating	- Use harder saw blades - Have bearings of the motor or the motor replaced - Ensure optimum flow of cooling water

# TROUBLESHOOTING

<b>PROBLEM</b>	<b>POSSIBLE CAUSE</b>	<b>SOLUTION</b>
Cracks in or near the diamond segment	<ul style="list-style-type: none"> <li>- Saw blade too hard</li> <li>- Fixed flange is worn out</li> </ul>	<ul style="list-style-type: none"> <li>- Use a softer blade</li> <li>- Have the fixed flange replace</li> </ul>
Saw blade is blunt	<ul style="list-style-type: none"> <li>- Motor shaft bearing</li> <li>- Saw blade type is unsuitable for the material being cut</li> <li>- Saw blade type is unsuitable for the machine performance</li> <li>- Saw blade too hard</li> <li>- Diamond segments are blunt</li> </ul>	<ul style="list-style-type: none"> <li>- Replace the bearing Of the motor shaft</li> <li>- Use appropriate type of saw blade</li> <li>- Sharpen the diamond saw blade</li> </ul>
Appearance of cut is not optimal	<ul style="list-style-type: none"> <li>- Poor tension in the blade material</li> <li>- Too much load placed on the saw blade</li> <li>- Diamond segments are blunt</li> </ul>	<ul style="list-style-type: none"> <li>- Return the saw blade to the manufacturer</li> <li>- Use a suitable saw blade</li> <li>- Sharpen the saw blade</li> </ul>
The center hole in the saw blade has become wider due to wear	<ul style="list-style-type: none"> <li>- The saw blade has slipped on the motor shaft when running</li> </ul>	<ul style="list-style-type: none"> <li>- The arbor of the saw blade must be fitted with an appropriate adaptor ring</li> <li>- Check the receiving flange and have it replaced if necessary</li> </ul>
Saw blade shows blooming colors	<ul style="list-style-type: none"> <li>- Lateral friction when cutting</li> </ul>	<ul style="list-style-type: none"> <li>- The material feed is too high; proceed more slowly</li> </ul>
Grinding marks on the saw blade	<ul style="list-style-type: none"> <li>- Material is not being fed parallel to the saw blade</li> <li>- Poor tension in the blade material</li> <li>- Too much load on the saw blade</li> </ul>	<ul style="list-style-type: none"> <li>- Ensure that the direction of feed is absolutely parallel to the saw blade</li> <li>- Adjust the roller table/have it adjusted</li> <li>- Have the saw blade tensioned</li> <li>- The material feed is too high, proceed more slowly</li> </ul>

# CUSTOMER SERVICE:

## After Sale Service

All customer service (technical questions, re-order of parts, etc.) will be provided by Pearl Abrasive Co.

All spare parts for after sales service will be stocked and shipped from our warehouse.

If requested, Pearl may arrange for our sales representatives to hold a training class for product knowledge at our dealers' location.

## How to Order

### Information Needed For Ordering:

- Serial Number of the Saw
- Model Number of the Saw
- When it was purchased and where
- Part Description

If you need to order replacement parts, please contact our customer service department. You can reach us at the contact information listed below.

### CUSTOMER SERVICE

Phone: (800) 969-5561 • Fax: (562) 928-3857

Web: [pearlabrative.com](http://pearlabrative.com)

## Return Policy

Return goods for credit or exchange on the basis of the following terms.

1. They must be current products.
2. Items returned for replacement or refund should be in original cartons and must be accompanied by a packing slip with the following information:  
Returned Goods Authorization (RGA) number obtainable from the Customer Service Department • List of items returned • Reason(s) for return(s) • Copy of original invoice(s)
3. Freight charges must be assumed by sender
4. Returning goods are subject to a 15% handling charge to cover our cost of repacking and restocking. All prices are subject to change without notice.

## REPLACEMENT PARTS LISTS - VX141MS

<b>PART NAME</b>	<b>PART No.</b>	
1	Screw M10XP1.5X20L	V390001
2	Blade Guard	V390002
3	Arbor Cover BBM/YBM307	V390003
4	Cross Bar Position Tube (Long) 2	V390004
5	Blade Lock Bolt M10X20 1.25 DIN933	V390005
6	Outer Flange	V390006
7	Arm Frame, Left Side	V390007
8	Rubber Cap	V390008
9	Bolt & Washer (3 pieces)	V390009
10	Side Frame (1)	V390010
11	Armature with Inner & Outer	V390011
12	Dry Kit Cross Bar	V390012
13	Sliding Rail (2)	V390013
14	Dust Collecting Pan	V390014
15	Cross Tub	V390015
16	Metal Pan Bracket	V390016
17	Metal Pan Frame	V390017
18	Left Front Joint	V390018
19	Cross Tube	V390019
20	Arm Frame Right side	V390020
21	Right Front Joint	V390021
22	Ruler Guide	V390022
23	Complete Cutting Table	V390023
23.1	Cutting Table Retention Bracket	V390023.1
24	U-Shape Roller Wheels (2)	V390024
25	Metal Bearing Rollers (2pcs./set)	V390025
26	Locking Table Bracket	V390026
27	Toggle Switch/ (20A)	V390027
28	Toggle Switch Safe Bracket	V390028
29	Inner Flange	V390029
30	Plate Blade Shaft Retaining (qty required=4)	V390030
31	Shaft Spacer Outer/ (6305 LLB)	V390031
32	Bearing Blade Shaft Outer/ (6305 LLB)	V390032
33	Blade Shaft BBM/YMN307	V390033
33.1	Key Woodruf	V390033.1
34	Gear Blade shaft	V390034
35	Bearing Motor Inner	V390035
36	Handle Bar	V390036
37	Tension Spring Left Side	V390037
38	Cutting Head Angle Main Bracket	V390038
39	Outer Motor Bearing	V390039
40	Tension Spring Right Side	V390040



**PART NAME****PART No.**

41	Spring Housing Cover	V390041
42	Motor Housing Includes Field Windings	V390042
43	Air Filter	V390043
44	Angle Adjustment Lock Pin	V390044
45	Cutting Head Casting Only	V390045
46	Collar Set Cutting Head	V390046
47	Cross Bar Position Tube (Short) 1	V390047
48	Cross Bar Position Bracket	V390048
49	Motor Air In-Tank Cover	V390049
50	Brush Cap (1)	V390050
51	Carbon Brushes (2 pcs./set)	V390051
52	Main Cross Bar	V390052
53	Shaft Spacer Inner	V390053
54	Folding Stand	V350MS
55	180° Angle Guide	V370060
56	Master Guide	V370064
57	Multiple Wrench	V390057
58	Master Guide Template Base	V390058
59	Master Guide Detachable Ruler Guide	V390059
60	Main Cross Bar Position Stopper	V390060
61	45°/90° Rip Guide	V370068



Note: If there is any part that is needed and has not been included in this parts list, please contact our customer service  
800-969-5561

# EXPLODED VIEW

## Accessories (Included)

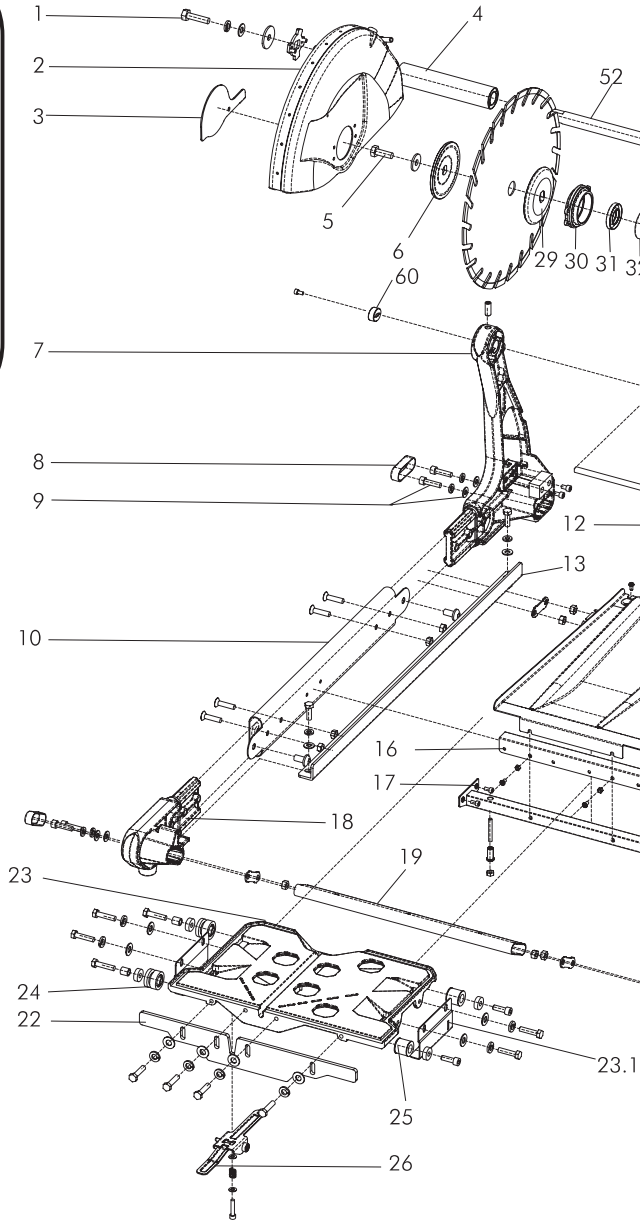
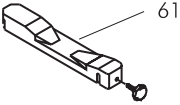
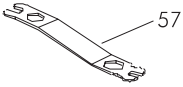

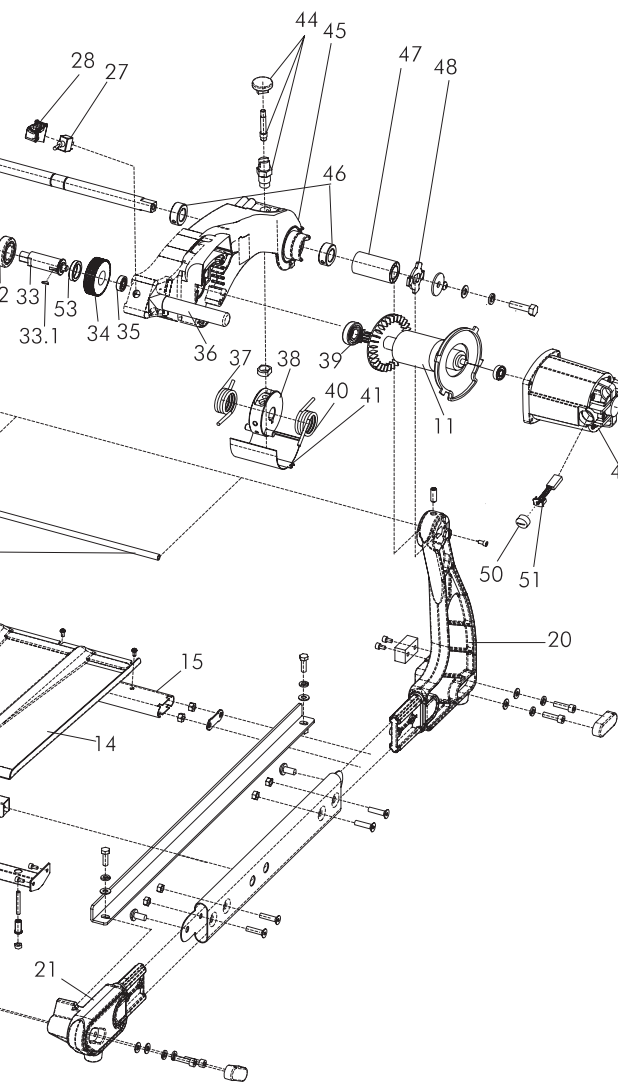

**Folding Stand (Optional)**

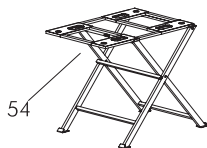

**180° Angle Guide (Optional)**

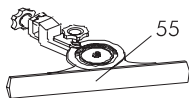

**Master Guide 45° /90°**

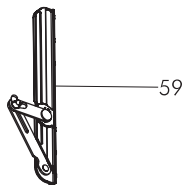
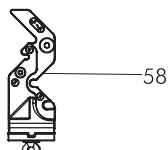
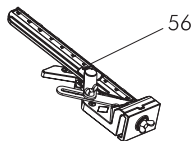

## CONTACT US:

We pride ourselves on our customer service. If you have any questions regarding our products, whether it may be product inquiry or troubleshooting, please don't hesitate to contact us at our corporate office. We will do our best to answer your questions. In some cases we may even refer you to a local sales representative that can better service you. You can call us at the contact information listed below.



### **CUSTOMER SERVICE**

6210 S. Garfield Avenue  
Commerce, CA 90040-0031  
Phone: (800) 969-5561  
Fax: (562) 928-3857  
Web: [pearlabrasive.com](http://pearlabrasive.com)

### **ILLINOIS, USA**

813 Central Avenue  
Wood Dale, IL 60191-1219

### **TEXAS, USA**

830 Avenue H East #303  
Arlington, TX 76011-7727

### **GEORGIA, USA**

4761 Hugh Howell Rd. Ste. N  
Tucker, GA 30084-5042

### **NEW JERSEY, USA**

745 Gotham Parkway  
Carlstadt, NJ 07072-2413

### **N. CALIFORNIA, USA**

1777 Rogers Avenue,  
San Jose, CA 95112-1109

### **ONTARIO, CANADA**

375 Pido Road  
Peterborough, Ontario K9J-6X7

All illustrations displayed in this manual are property of Pearl Abrasive Co. and shall not be duplicated or reproduced without the express written consent of Pearl Abrasive Co.