

K950 ACTIVE

Operator's manual (EPA)



Read these instructions carefully and make sure you understand them before using the machine.

SYMBOL EXPLANATION

Symbols on the power cutter:



WARNING! The power cutter can be dangerous! Careless and incorrect use can result in serious or fatal injury to the operator or others.



Please read the instructions carefully and make sure you understand them before using the power cutter.



Always wear:

- Approved protective helmet
- Approved hearing protection
- Protective glasses or visor



Warning

Cutting creates a lots of dust which can cause inhalation damages. Use appropriate dust mask or respirator protection. Avoid breathing petrol fumes and exhaust gases. Provide for good ventilation.



Warning

Sparks from the cutting blade can cause fire in combustible materials such as: petrol (gas), wood, dry grass etc.

Symbols in the Operator's Manual:

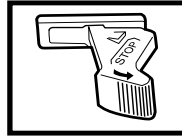

Switch off the engine by moving the stop switch to the STOP position before carrying out any checks or maintenance.

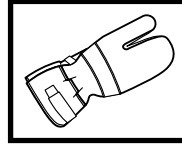

Always wear approved protective gloves.

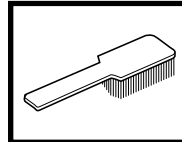

Regular cleaning is required.

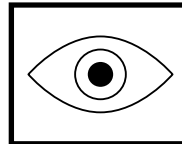

Visual check.

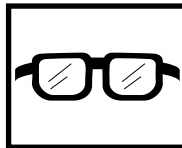

Protective glasses or a visor must be worn.

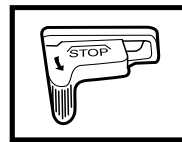

Run position.

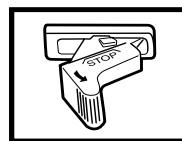

Stop with spring loaded return to Run position.

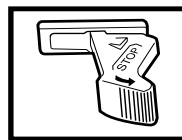

Stop, in fixed position.

CONTENTS

Before using your new Power cutter

- Read the Operator's Manual carefully.
- Check the assembly and adjustment of the cutting blade, see chapter "Assembly".
- Start the engine and check the carburetor settings. See chapter "Maintenance", section "Carburetor". When adjusted correctly the cutting blade should not rotate when idling. Setting the idling speed is described in the Operator's Manual. Adjust the speed according to these instructions. Do not use the power cutter if the idling speed is not correctly adjusted!
- Let your Partner dealer check the power cutter and carry out essential adjustments and repairs.

Maintenance, replacement, or repair of the emission control devices and systems may be performed by any nonroad engine repair establishment or individual.



WARNING!
Under no circumstances should you modify the original design of the power cutter without approval from the manufacturer. Always use genuine spare parts. Unauthorized modifications or accessories may lead to serious injury or death.

Your warranty does not cover damage or liability caused by the use of non-authorized accessories or replacement parts.



WARNING!
Use of products which cut, grind, drill, sand or shape material can generate dust and vapors which may contain harmful chemicals. Know the nature of the material being worked on and wear appropriate dust mask or respirator protection.



WARNING

The engine exhaust from this product contains chemicals known to the State of California to cause cancer, birth defects or other reproductive harm.

You will find the following label on your power cutter:





WARNING

Cutters can be dangerous!

For safe operations follow all safety precautions in owners manual.

- Only trained and qualified personnel shall operate this cutter.
- Only use high speed reinforced wheels approved for free-hand cutting and for the maximum speed rating of cutter.
- Before each use, check wheel and guard for any damage.
- Use ear, eye, head and hand protectors, protective clothing and protective footwear.
- Keep all bystanders well away from the operating area.
- Adjust guard to keep rear section in close workpiece contact.

IMPORTANT ENGINE INFORMATION

PARTNER K1250 ACTIVE 119CC VHV119UB258B

PARTNER K950 ACTIVE 94CC VHV094UB258B

PARTNER K650/700 ACTIVE 71CC VHV071UB258B

THESE ENGINES CONFORM TO 1997 U.S. EPA EMISSION REGULATION FOR SMALL NON-ROAD ENGINES. REFER TO OPERATORS MANUAL FOR MAINTENANCE SPECIFICATIONS AND ADJUSTMENTS.

PARTNER INDUSTRIAL PRODUCTS PARTILLE SWEDEN

List of Contents

Symbol explanation	2
Safety instructions	
Personal protective equipment	4
The power cutter's safety equipment	4
Control, maintenance and service of the machine's safety equipment	4
General safety instructions	6
Transport and storage	6
Fuel safety	7
General working instructions	7
Cutting	7
Kickback	8
Care and storage	9
Cutting blades	10
General	10
Abrasive blades	10
Diamond blades	11
What is what?	
What is what on a power cutter?	12
Assembly	
Fitting the cutting head	13
Checking the drive shaft and flanges	13
Fitting the cutting blade	13
Fuel handling	
Fuel mixture	14
Fuelling	14
Start and stop	
Start and stop	15
Maintenance	
Adjusting the drive belt	16
Changing the drive belt	16
Carburetor	17
Fuel filter	18
Air filter	18
Starter	19
Ignition system	20
Spark plug	20
Cooling system	20
Muffler	20
Daily maintenance	21
Weekly maintenance	21
Monthly maintenance	21
Technical Data	
K950 Active	22
Emission Control Warranty Statement	
Your warranty rights and obligations	23

Partner Industrials has a policy of continuous product development and therefore reserves the right to modify the design and appearance of products without prior notice.

SAFETY INSTRUCTIONS



WARNING! Incorrect or careless use of a power cutter can turn it into a dangerous tool that can cause serious or even fatal injury. It is extremely important that you read and understand this manual.

PERSONAL PROTECTIVE EQUIPMENT



WARNING! When using a power cutter, protective equipment approved by the appropriate authorities must be used. Personal protective equipment does not eliminate the risk of accidents, however, it can reduce the effects of an injury in the event of an accident. Ask your dealer for help when choosing protective equipment.

- PROTECTIVE HELMET
- EAR PROTECTION
- PROTECTIVE GLASSES OR FULL FACE PROTECTION

- BREATHING MASK

- HEAVY-DUTY, FIRM GRIP PROTECTIVE GLOVES

- SNUG-FITTING, HEAVY-DUTY, COMFORTABLE CLOTHING THAT ALLOWS FULL FREEDOM OF MOVEMENT

- LEG PROTECTION (TO PROTECT AGAINST SPARKS AND CUTTING FRAGMENTS)

- ANTI-SLIP BOOTS WITH STEEL TOE CAPS

- FIRST AID KIT SHOULD ALWAYS BE ON HAND

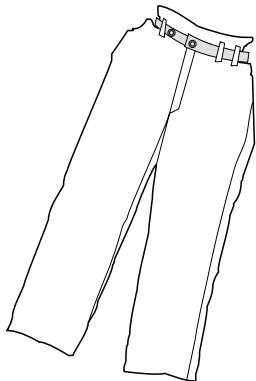
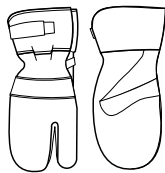
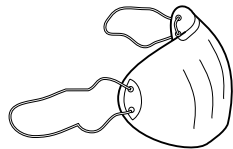
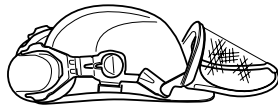

THE POWER CUTTER'S SAFETY EQUIPMENT

This section describes the power cutter's safety equipment, its function and how checks and maintenance are carried out to ensure that it operates correctly. (See the chapter "What is what" to locate where this equipment is positioned on your power cutter.)



WARNING! Never use a power cutter with defective safety equipment. Follow the control, maintenance and service instructions described in this manual.

1 Anti-vibration system

Your power cutter is equipped with an anti-vibration system. This is designed to give as low vibration levels and comfortable usage as possible.

The power cutter's anti-vibration system reduces the transfer of vibration between the engine/cutting equipment and the operator. The engine body including the cutting equipment is suspended in a handle system via anti-vibration elements.

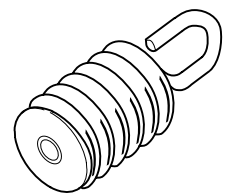
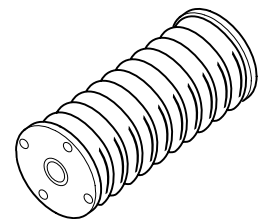
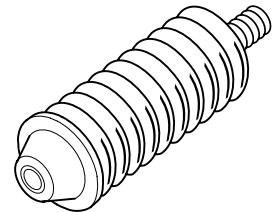
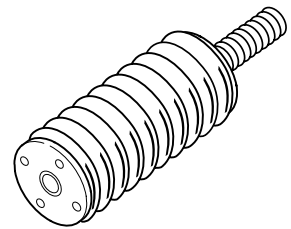

2 Stop switch

The stop switch should be used to stop the engine.

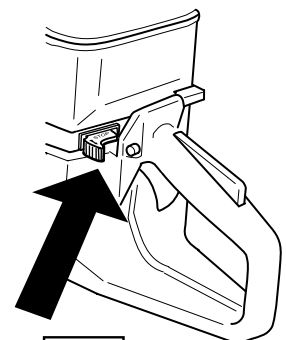

SAFETY INSTRUCTIONS

3 Muffler



WARNING! During use and for some time after the muffler is very hot. Do not touch the muffler if it is hot!

The muffler is designed to give the lowest possible noise level and to direct the engine's exhaust fumes away from the user. The engine's exhaust fumes are hot and can contain sparks, which can lead to the outbreak of fire.

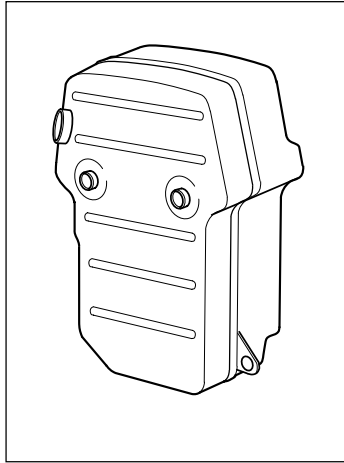

IMPORTANT INFORMATION! It is extremely important that the instructions for checking, maintaining and servicing the muffler are followed. (see the section "Control, maintenance and service of the power cutter's safety equipment").

4 Blade guard for the cutting blade



WARNING! Always check that the blade guard is correctly fitted before starting the machine.

The blade guard is mounted above the cutting blade and prevents cutting fragments from being thrown towards the user.

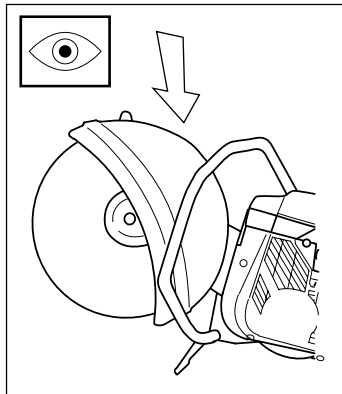

Control, maintenance and service of the machine's safety equipment



WARNING! All service and repairs to the power cutter require special training. This applies especially to the power cutter's safety equipment. If the power cutter does not meet any of the controls listed below you should contact your service workshop. The purchase of one of our products guarantees that professional repair and servicing will be carried out on it. If the point of purchase is not one of our servicing dealers, please ask for details of the closest service workshop.

1 Anti-vibration system

Check the anti-vibration elements regularly for material cracks and deformation.

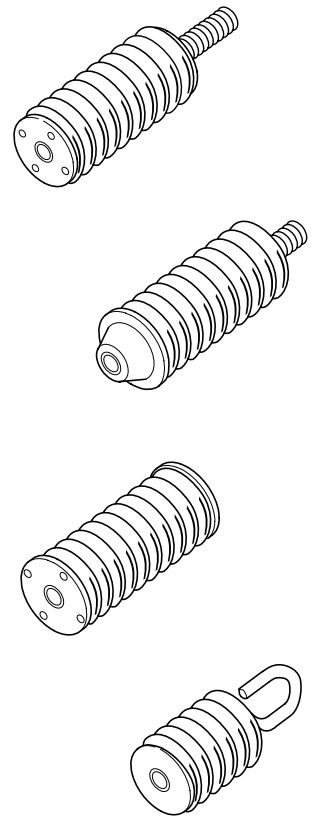
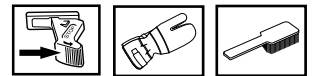

Check that the anti-vibration elements are securely mounted between the engine unit and the handle system.

2 Stop switch

Start the engine and make sure that the engine stops when the stop switch is moved to the stop position.

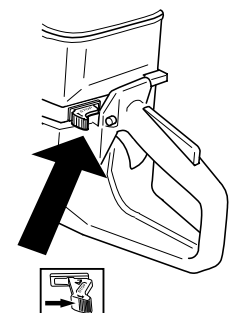

SAFETY INSTRUCTIONS

3 Muffler

Never use a machine that has a defective muffler.

Check regularly that the muffler is secured to the engine body.

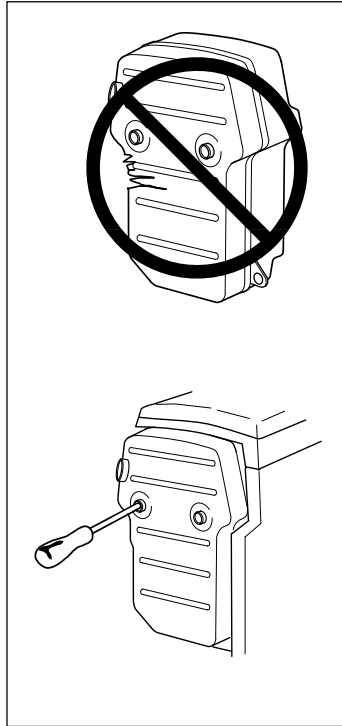

4 Blade guard for the cutting blade

Never use a defective blade guard or a blade guard that is not fitted correctly.

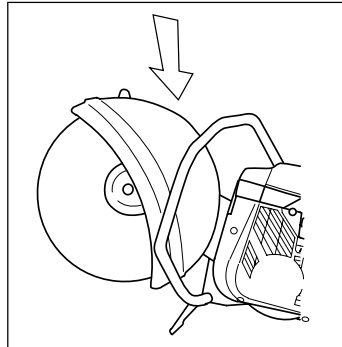

WARNING! Check that the cutting blade is fitted correctly and does not show signs of damage. A damaged cutting blade can cause personal injury.



WARNING! Never use a power cutter with defective safety equipment. The power cutter's safety equipment should be checked and maintained as described in this Operator's Manual. If your power cutter does not meet any of these controls you should contact your service workshop.

GENERAL SAFETY INSTRUCTIONS

IMPORTANT INFORMATION!

Do not use the power cutter until you have read the entire contents of this Operator's Manual.

All servicing, in addition to the points listed in the section "*Control, maintenance and service of the power cutter's safety equipment*", should be carried out by trained service specialists.

- Use the equipment recommended in the chapter "*Personal safety equipment*".
- Never use the machine when you are tired, under the influence of medicines/drugs or alcohol.
- Do not lend the power cutter to anyone without providing this Operator's Manual. Ensure the person using the power cutter understands the information in this Operator's Manual.

Transport and storage

- Store the power cutter under lock and key so that it's out of reach for children and unauthorised persons.
- Do not store or transport the power cutter with the cutting blade fitted.

SAFETY INSTRUCTIONS

Fuel safety (Filling/Fuel mixture/Storage)



WARNING! Exercise great care when handling fuel. Bear in mind the risk of fire, explosions and inhaling fumes.

- Never fill the machine while the engine is running.
- Provide good ventilation when filling or mixing fuel (gasoline and 2-stroke oil).
- Move the machine at least 3 m from the filling position before starting.
- Never start the machine:
 - a) If you have spilt fuel on it. Wipe up all spillage.
 - b) If you have spilt fuel on yourself or your clothes. Change your clothes.
 - c) If there is a fuel leak. Make regular checks for leakage from the fuel cap and the fuel supply pipes.
- Store the power cutter and fuel so that any leakage or fumes do not risk coming into contact with sparks or naked flames. For example, electric machines, electric motors, electrical switches/power switches, heaters or the like.
- When storing fuel, approved containers intended for this purpose must be used.
- When storing the power cutter for long periods the fuel tank must be emptied. Contact your local fuel station to find out how to dispose of excess fuel.
- Use a Partner fuel can with an anti-spill device.

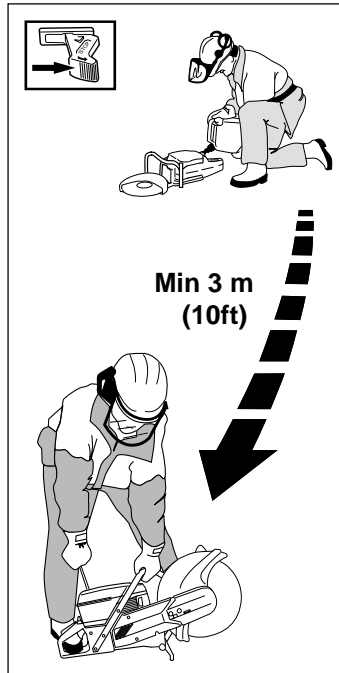

WARNING! Use a Partner fuel can with an anti-spill device. Fuel and fuel fumes are highly flammable. Think of the risks of fire, explosion and breathing in fumes. Stop the engine before refuelling. Do not overfill with fuel. Mop up any spills on the ground or the machine. If you spill fuel on yourself or your clothes, change your clothes. Move the machine at least 3 metres from the refuelling site before starting.

GENERAL WORKING INSTRUCTIONS

This section takes up the basic safety precautions for working with the power cutter. Follow these general working instructions, but never use a machine without the possibility of calling for help in the event of an accident.

Basic safety precautions

IMPORTANT INFORMATION! Never work with a power cutter that is defective or incorrectly adjusted. Do not work with a power cutter that is incomplete or where assembly has not been carried out in a satisfactory manner. Check that the cutting blade stops rotating when the throttle is released. If you encounter a situation where you are uncertain how to proceed you should ask an expert. Avoid all usage which you consider to be beyond your capability.

- Check that no one is in the immediate vicinity when the machine is started or while working with the machine to ensure that people, animals or other things cannot affect your control of the power cutter.
- Avoid usage in unfavourable weather conditions, for example, thick fog, heavy rain, strong winds or extreme cold, etc. To work in bad weather conditions is tiring and can create dangerous circumstances, e.g. slippery surfaces.
- Never start to work with the power cutter before the working area is clear and you have a firm foothold. Look out for any obstacles with unexpected movement. Ensure when cutting that no material can become loose and fall, causing operating injury. Take great care when working on sloping ground.
- Make sure clothing and parts of the body do not come into contact with the cutting blade when the engine is started.
- Maintain a safe distance from the cutting blade when the engine is running.
- The blade guard should always be fitted when the engine is running.
- Ensure that the working area is sufficiently illuminated to create a safe working environment.
- Some working positions may create greater stress on the operator.
- Check the cutting area for buried cables and wires.



Only use the machine in areas with good ventilation. Neglect can result in serious injury or death.

Cutting



WARNING! A safe distance from the power cutter is 15 metres. You are responsible that animals and onlookers are not in the working area. Do not start to work with the power cutter before the working area is clear and you have a firm foothold.

- Start cutting with the engine at full throttle.
- Always hold the power cutter firmly, with both hands. Hold the machine so that the thumb and fingers grip around the handle.

SAFETY INSTRUCTIONS



Over exposure to vibrations can result in blood-vessel or nerve injury to persons suffering with blood circulation problems. Seek medical attention if you experience physical symptoms that can be related to over exposure to vibrations. Examples of such symptoms are numbness, lack of feeling, "tickling", "pricking", pain lack of or a reduction in normal strength, changes in the colour of the skin or its surfaces. These symptoms normally appear in the fingers, hands or wrists.

Cutting technique

The technique described below is of a general character. Check information for each blade regarding individual cutting characteristics. (For example, a diamond blade requires less feeding pressure than a abrasive blade).

1. Support the work piece in such away that you can predict what will happen and so it will not pinch.
2. Always cut at full throttle.
3. Start cutting gently, do not force or squeeze the blade in.
4. Use a high blade speed.
5. Move the blade slowly backwards and forwards.
6. Use a small part of the blade's cutting edge.
7. Only use the blade's cutting edge when cutting.
8. Cut with the blade fully vertical – at right angles to the work piece.

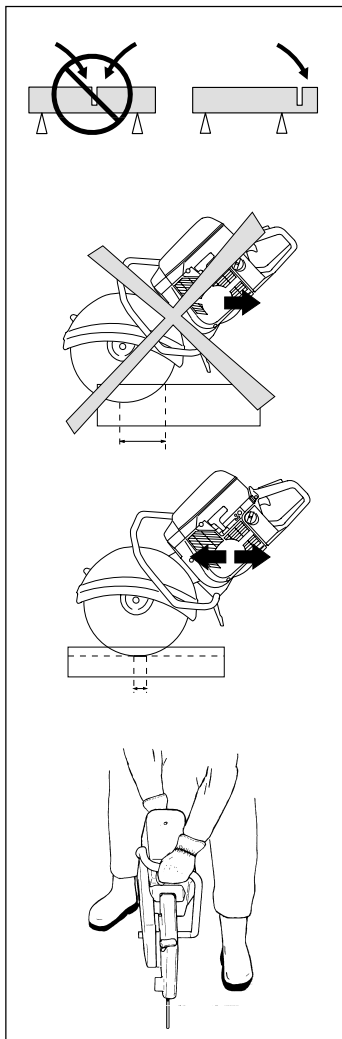

WARNING! Under all circumstances avoid cutting using the side of the blade; it will almost certainly be damaged, break and can cause immense damage. Only use the cutting section.



WARNING! Do not lean the blade to the side, this can cause the blade to jam or break with personal injury as a consequence.

Water cooling



WARNING! Water cooling, which is only used for petrol-driven power cutters and when cutting concrete, cools the cutting blade and increases its service life as well as reduce dust formation (see the section "Abrasive blades"). Among the disadvantages are difficulties at very low temperatures, the risk of damaging the floor and other sections of the building and risk for slippage.

Sharpening diamond blades

Blades can become dull when the wrong feeding pressure is used or when cutting some materials such as heavily reinforced concrete. To force a dull blade results in overheating and finally the loss of segments (part of the blade).

Sharpen against a soft material such as sandstone, silica or haydite brick.

Blade vibration

The blade can become out of shape (not round) and vibrate if a too high feeding pressure is used or if the blade is pressed into the work piece.

A lower feeding pressure ought to stop the vibration. Otherwise replace the cutting blade.

Kickback

Kickback can occur very suddenly and with great force. If the following directives are not followed, it can result in serious or even fatal injury.

If the sector of the blade illustrated below is used for cutting the blade can start to climbing and kickback the power cutter upwards and backwards towards the user with immense force.

How to avoid kickback

1. Never cut with the segment illustrated in the diagram.
2. Keep a good balance and a firm foothold.
3. Use both hands and take a firm grip with the thumb and fingers around the handle.
4. Keep the work piece at a comfortable distance.
5. Use the cutter at full throttle.
6. Take care when inserting the blade in an existing cut.
7. Never cut above shoulder height.
8. Be alert to movement of the work piece or anything else that can occur, which could cause the cut to close and pinch the blade.

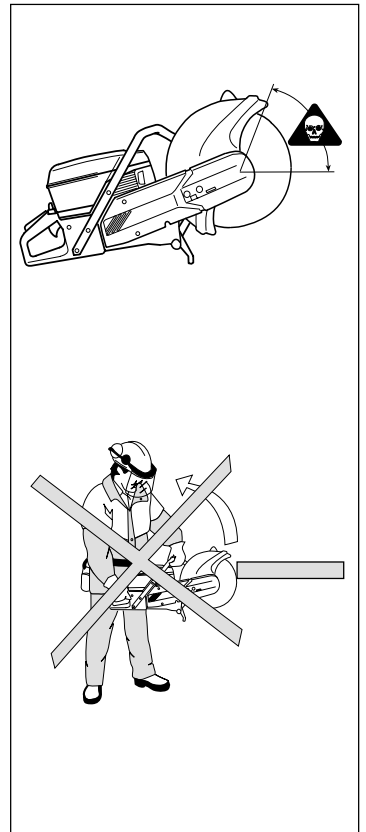

SAFETY INSTRUCTIONS

Pull in

Pull in occurs when the lower part of the blade is suddenly stopped or when the cut closes. (To avoid this see the section "How to avoid kickback" and "Pinching/rotation" below).

Pinching/rotation

Pinching occurs when the cut closes. The power cutter can be drawn suddenly and powerfully downwards.

How to avoid pinching

Support the work piece in such a way that the cut remains open during the cutting operation and when the cut is finished.

Drying the blade

After using the blade with water cooling, let the cutter run for approx. half a minute so that the blade dries.

If a damp blade is stored it can become unbalance and cause damage.

Check the speed of the drive shaft

Use a tachometer regularly to check the speed of the drive shaft when the cutter is running at working temperature and at full throttle without a load. The maximum speed is stated on the unit.

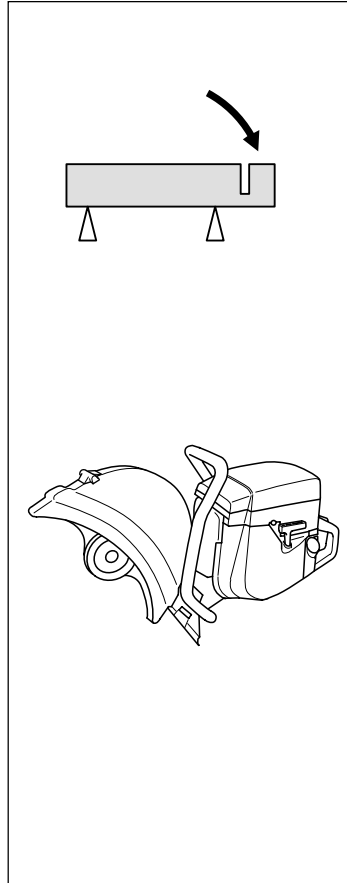

WARNING!

If the speed is higher than that stated then the unit must be adjusted by an authorised service workshop before it is used.

Care and storage

General

Partner's power cutters are robust and durable. However, as they are used for high speed operations all servicing should be carried out on time and as specified, so that the power cutter always works effectively and safely.

Read this Operator's Manual to determine which service routines you can carry out and ensure that all other service work is carried out by an authorised service workshop.

Power Cutter

Always handle the power cutter with care and store it with the blade removed.

Blades

- All blades should be removed from the cutter after use and stored carefully.
- Special care should be taken with abrasive blades.
- Blades must be stored on a firm, level surface. If blades are supplied with a backing pad then a spacer should be used to keep them flat.
- Avoid moisture and temperature extremes.
- Remove the blades before the cutter is moved or transported.
- Inspect new blades for transport or storage damage.

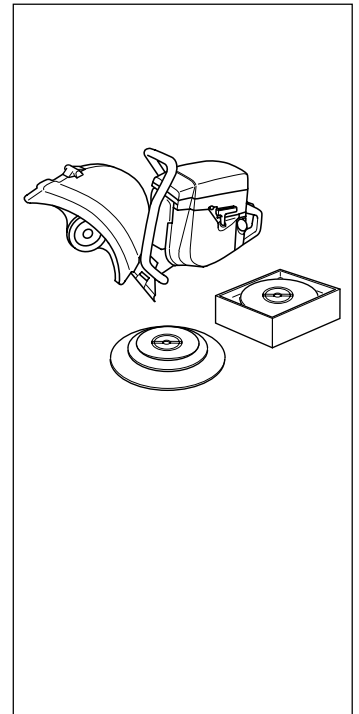

SAFETY INSTRUCTIONS

CUTTING BLADES

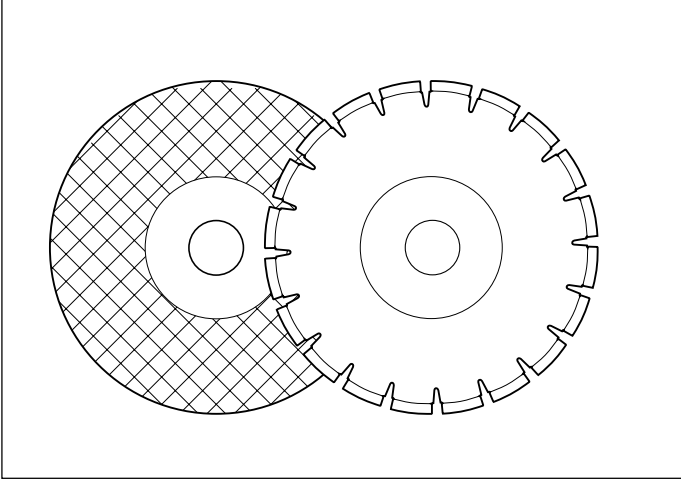

General

Cutting blades are available in two standard designs; abrasive blades and diamond blades.

 **WARNING!**
A cutting blade may burst and cause injury to the operator.

High speed portable tools

Cutting blades of the make Partner are manufactured for portable, high speed, power cutters. If other makes of cutting blades are used, ensure the blades comply with all the directives and requirements attributed to the specific type of power cutter.

 **WARNING!**
Never exceed the maximum working speed of a cutting blade.

Special blades

Some cutting blades are designed for stationary equipment and for use with attachments. These types of cutting blades must not be used on portable, power cutters.

 **WARNING!**
Never use a cutting blade for any other purpose than that it was intended for.

Always contact local authorities and make sure you are following applicable directives.

Abrasive blades

The cutting material in an abrasive blade consists of abrasive corn that is held together by an organic bonding agent. "Reinforced blades" are made up of a fabric or fibre base that prevents total breakage at maximum working speed if the blade should be cracked or damaged. (The term reinforced does not refer to those cutting blades that are only reinforced around the flange).

A cutting blade's performance is determined by the type and size of abrasive corn, and the type and hardness of the bonding agent.

Characteristics that give the blade a shorter service life and greater cutting capacity are said to make the blade "softer". A blade with a longer service life and slower cutting capacity is a blade with a "harder" effect.

High quality cutting blades are normally more economical. Lower quality cutting blades usually have an inferior cutting capacity and shorter service life, which results in higher cost per processed material.

ABRASIVE BLADES, TYPES AND USES			
	Use		
Blade type	General characteristics	Material	Water cooling
Concrete	Universal usage, economical	Concrete, asphalt, stone, brickwork, cast iron, aluminium, copper, brass, cables, rubber, etc.	Increases the blade's service life. Reduces dust formation. Recommended.
Metal	Unbeatable for steel (not suitable for concrete, etc.)	Steel, steel alloys and other hard metals.	Reduces cutting capacity NOT recommended.

SAFETY INSTRUCTIONS

Type of cutting blades

Check that the blade is approved for the same or higher speed according to the approval plate of the engine. Do not exceed the maximum working speed stated on the blade.

Damage

- Ensure the blade is not cracked or damaged in any other way.
- Test the blade by hitting it gently with a piece of wood. If the blade does not give a full-sounding ring then it is damaged.
- Never use a blade that has fallen on the floor.

Assembly

- Check that the blade is fitted correctly and is secure.
- Follow all specifications in the table below.

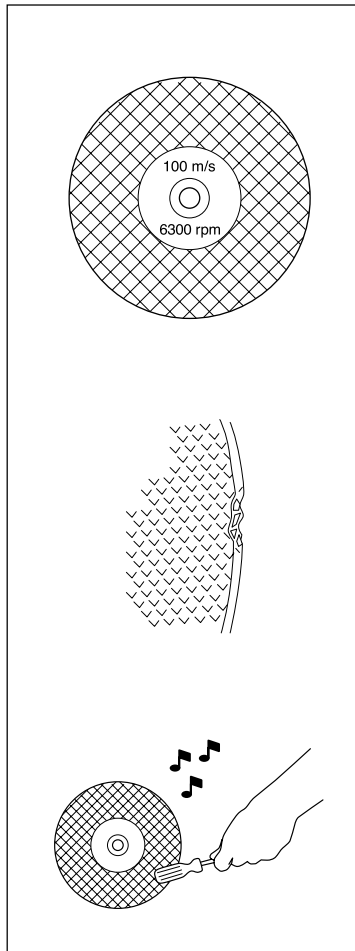

Specifications for fitting blades		
Standard blades centre hole (spindle)	inches mm	.787 7/8 1 20 22,2 25,4
Reducing bush*	Max. thickness Min thickness	Blade thickness 3 mm (1/8")
Backing pad (Must be used)	Material	Highly compressible, e.g. blotting paper
	Max. thickness	0,5 mm (.020")
Spindle hole/ drive shaft	Play	0,2 mm (.010")
Flange tightening	The blade does not slip, flange not bent	
Blade/guard	Check that the blade runs free of the guard.	

* Plastic reducing bushes may only be used with abrasive blades. Do not use reducing bushes with diamond blades or tungsten carbide tipped blades. We recommend that the spindle is replaced so that it fits the blades to be used rather than using a reducing bush. Contact your service workshop for details.

Guard

Check that the guard is not cracked or shows signs of any other damage. Clean the inside of the guard before fitting a new blade. Check that the guard can be adjusted.

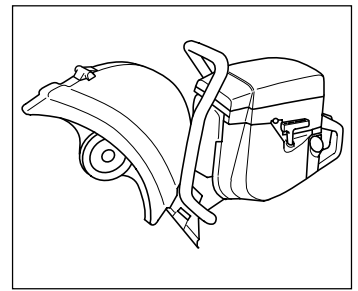

Diamond blades

Diamond blades are basically made in the same way as abrasive blades but are manufactured from industrial diamonds held together by a bonding agent.

DIAMOND BLADES, TYPES AND USES			
Diamond blade	General characteristics	Material	Water cooling
	Low cost per cutting operation. Less blade changes. Constant cutting depth. Less dust.	All brickwork, reinforced concrete and other composite materials. NOT recommended for metal.	Increases the blades service life.



WARNING!
Cool a diamond blade continuously with water to prevent overheating, which can cause the blade to break and pieces being thrown off resulting in injury and damage.

Using diamond blades

Proceed as follows:

- Let the blade rotate in the same direction as the arrow indicates.
- Cool continually with water.
- Keep the blade sharp.
- Remove the blade when transporting the cutter.

Avoid:

- Running the blade in the wrong direction.
- Forcing a dull blade or wedging the blade into a cut.
- Transporting the cutter with the blade fitted.
- Letting the blade fall on the work piece.

Dry diamond blades

Dry diamond blades are a new generation of blades that do not require water cooling. However, the blades are still damaged by excessive heat. It is good economics to let the blade cool by simply lifting the blade from the cut every 30–60 seconds and let it rotate in the air, for 10 seconds to cool.

WHAT IS WHAT?

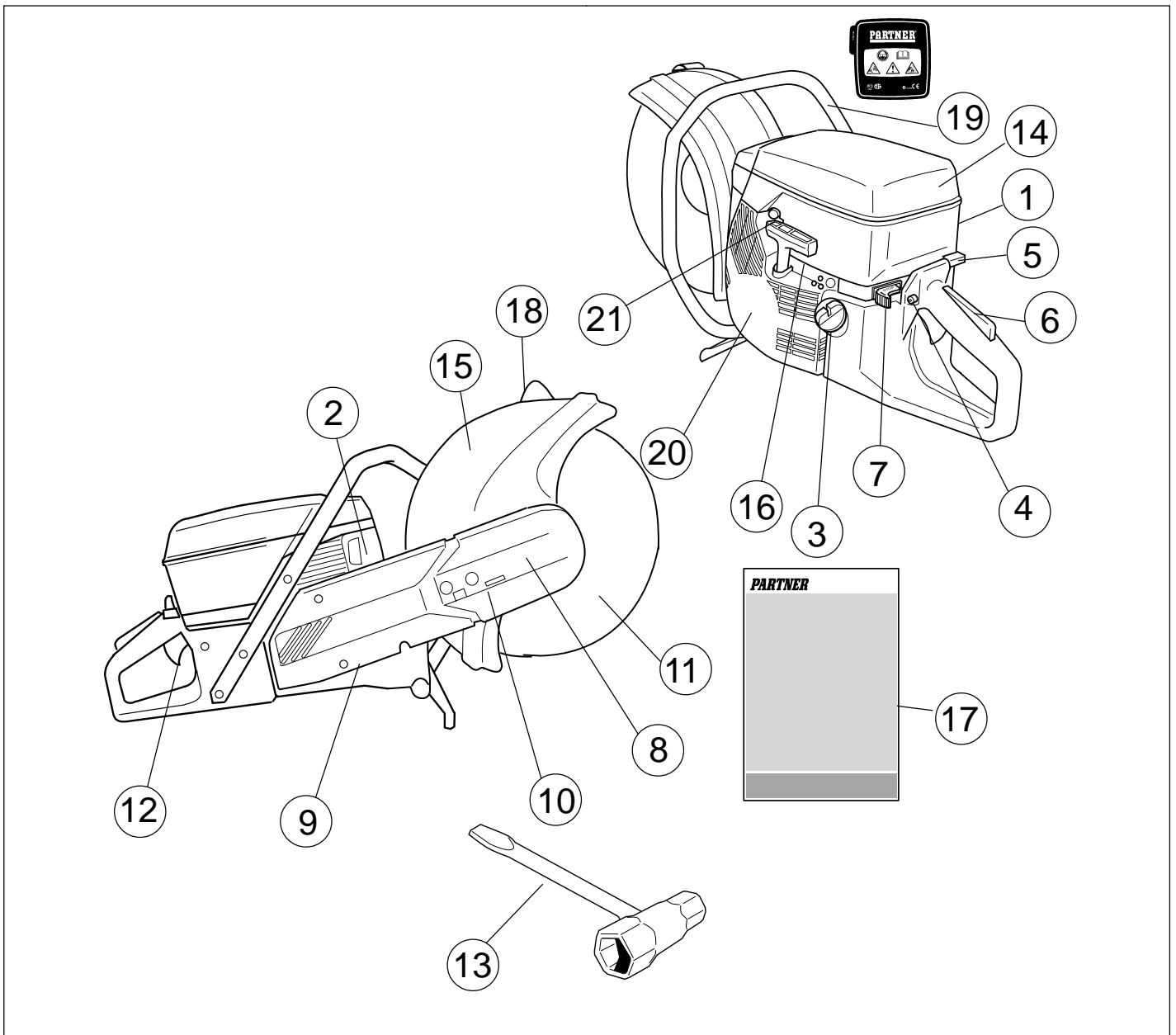

What is what on a power cutter?

- | | |
|-----------------------------|---------------------------------------|
| 1. Cylinder cover | 12. Throttle control |
| 2. Muffler | 13. Combination spanner |
| 3. Fuel tank | 14. Air filter cover |
| 4. Starter throttle catch | 15. Blade guard |
| 5. Choke | 16. Starter handle |
| 6. Throttle trigger lockout | 17. Operator's manual |
| 7. Stop switch | 18. Adjustment handle for blade guard |
| 8. Cutting head | 19. Front handle |
| 9. Cutting arm | 20. Starter |
| 10. Belt tensioning screw | 21. Decompression valve |
| 11. Cutting blade | |

ASSEMBLY

Fitting the cutting head

Remove the bolts (1). Remove the cover. Fit the drive belt over the clutch drum. Refit the cover and tighten the bolts.

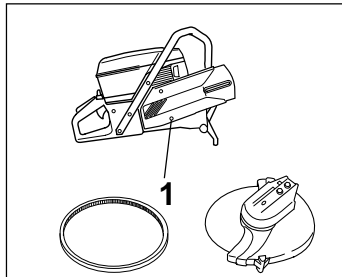

Feed the drive belt over the pulley on the cutting head (2).

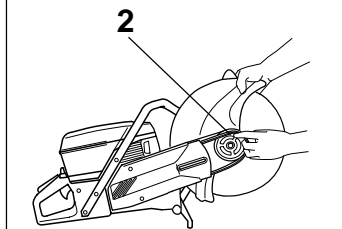

Slide on the belt cover and secure the cutting head together with the belt guard. Tighten both bolts (4) by hand.

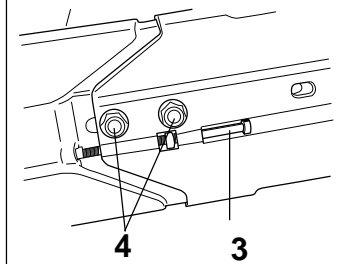

Screw in the tensioning screw (3) so that the square nut is in line with the arrow on the belt guard. This automatically adjusts the belt to the correct tension. Tighten both bolts (4) using the combination spanner.

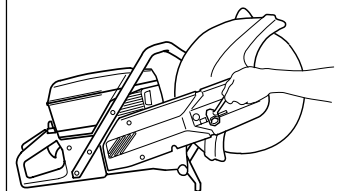

NOTE!

After fitting a new belt the belt tension must be readjusted after the first two tanks of fuel have been used.

Checking the drive shaft and flanges

- Check that the threads on the drive shaft are undamaged.
- Check that the contact surfaces of the cutting blade and flanges are flat, run correctly on the spindle and are free from foreign objects.

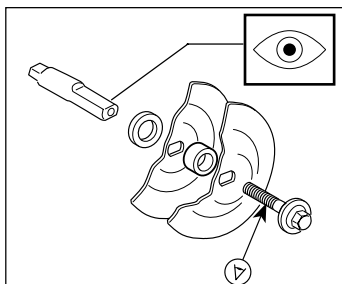

Do not use flanges that are twisted, have damaged edges, untrue or dirty. Do not use different size flanges.

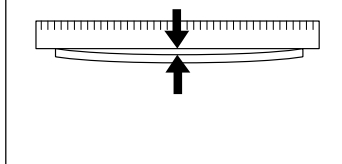

Fitting the cutting blade

Partner cutting blades are manufactured and approved for freehand cutting. The paper labels on each side of the blade are there to distribute the pressure from the flange washer and prevent the blade from slipping.

The blade is placed between the flange hub (A) and the flange washer (B). The flange washer is turned so that it fits in the flange hub. The cutting blade is tightened using the socket spanner 501 69 17-02.

The shaft can be locked using a screwdriver, steel pin or the like. This is slid in as far as possible. The blade is tightened clockwise.

Tightening torque for the bolt holding the blade is:
15-25 Nm (130-215 in.lb).

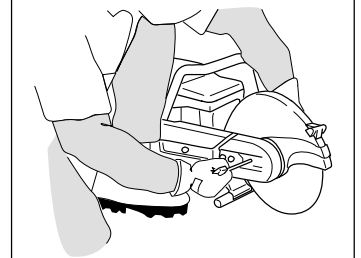
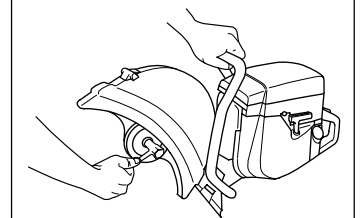
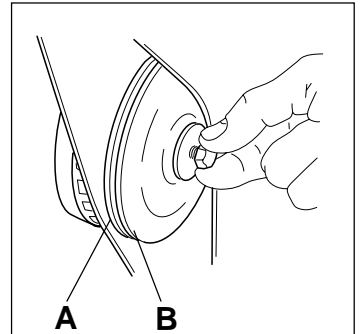

Blade guard

The blade guard should always be fitted on the power cutter.

The guard should be adjusted so that the rear section is close to the work piece. Cutting fragments and sparks are then collected by the guard and led away from the user.

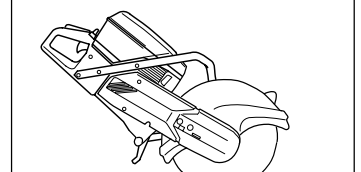

WARNING!

16 inch blade and blade guard should only be used on power cutters originally equipped with a 16" blade guard. If a blade guard is fitted as a spare part on a power cutter originally equipped with a 14" blade guard, the 16" cutting blade will rotate too fast. A cutting blade with too high speed can burst or cause serious injury and damage.

FUEL HANDLING

Fuelmix

IMPORTANT! The power cutter is equipped with a two-stroke engine and must always be run using a mixture of gasoline and two-stroke engine oil. It is important to accurately measure the amount of oil to be mixed to ensure that the correct mixture is obtained. When mixing small amounts of fuel, even small inaccuracies can drastically affect the ratio of the mixture.



Always provide for good ventilation when handling fuel.

Gasoline

- This engine is certified to operate on unleaded gasoline.
- Use good quality unleaded gasoline.
- The lowest recommended octane rating is 87. If you run the engine on lower octane rating than 87 so-called "knocking" can occur. This leads to an increased engine temperature, which can result in a serious engine breakdown.
- When working at continuous high revs a higher octane rating is recommended.

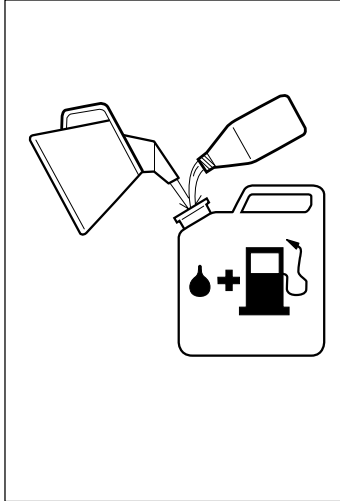

Two-stroke oil

- For the best results use PARTNER two-stroke oil, which is especially developed for power cutters. Mixing ratio 1:50 (2%).
- Never use two-stroke oil intended for water cooled outboard engines, so-called, outboard oil.
- Never use oil intended for four-stroke engines.

Gasoline	Oil 2%(1:50)
Lit.	Lit.
5	0,10
10	0,20
15	0,30
20	0,40
US gallon	US fl. oz.
1	2 1/2
2 1/2	6 1/2
5	12 7/8

Mixing

- Always mix the gasoline and oil in a clean container intended for fuel.
- Always start by filling half the amount of the gasoline to be used. Then add the entire amount of oil. Mix (shake) the fuel mixture. Add the remaining amount of gasoline.
- Mix (shake) the fuel mixture thoroughly before filling the saw's fuel tank.
- Do not mix more than max. one month's supply of fuel.
- If the saw is not used for some time the fuel tank should be emptied and cleaned.
- This engine is certified to operate on unleaded gasoline.



Fuelling



WARNING! The following precautions reduce the risk of fire:

- Do not smoke or place any sources of heat in the vicinity of the fuel.
- Never refuel when the engine is running.
- Open the fuel cap slowly when fuelling so that any over pressure is released slowly.
- Tighten the fuel cap carefully after refuelling.
- Always move the machine from the fuelling place before starting.

- Keep the handle dry, clean and free from oil and fuel.

- Clean around the fuel cap. Clean the fuel tank regularly. The fuel filter should be changed at least once per year. Contamination in the tank can disrupt operations. Ensure that the fuel is well mixed by shaking the container before filling the tank.

- Always exercise care when filling the fuel. Move the power cutter at least three metres from the filling area before starting. Make sure the fuel cap is tightened.

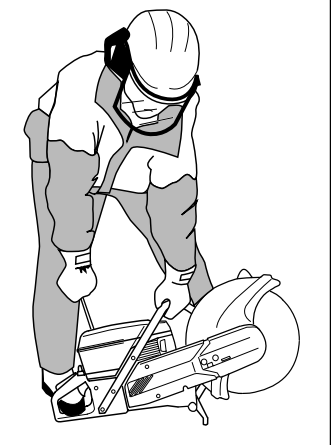
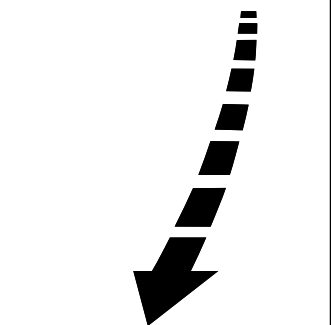
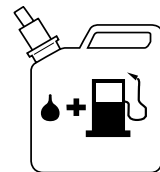
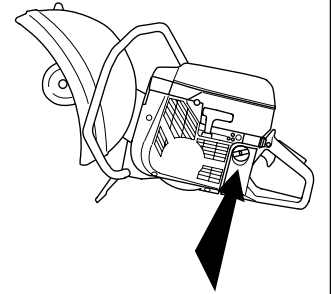

START AND STOP

Start and stop



WARNING! Before starting observe the following:

- Do not start the power cutter without the cutting arm or cutting head fitted. Otherwise the clutch can come loose and cause personal injury.
- Always move the power cutter from the filling area before starting.
- Ensure that you and the machine stand firmly and that the cutting blade rotates freely.
- Make sure no unauthorised persons are within the working area.

Starting a cold engine

IGNITION:

Slide the stop switch to the left.

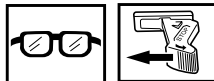

CHOKE:

Pull out the choke.



STARTER THROTTLE CATCH

Press in the throttle control and thereafter the starter throttle catch (A). Release the throttle control and the throttle is blocked in half throttle position. The catch is released when the throttle control is pressed in all the way.

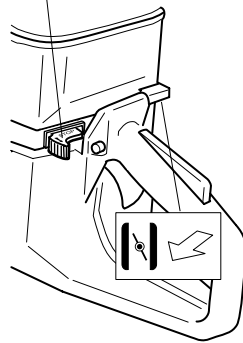

DECOMPRESSION VALVE

Press in the valve to reduce the pressure in the cylinder, this makes starting the power cutter easier. The decompression valve should always be used when starting. When the machine has started the valve automatically returns to its original position.

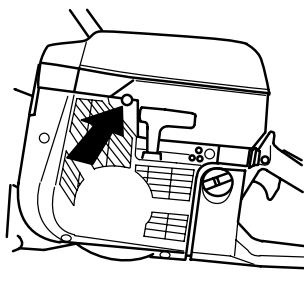

Starting a warm engine

Use the same procedure as for starting cold engine but without choke. Fast idle is received by first set the choke control in choke position, and then back again.

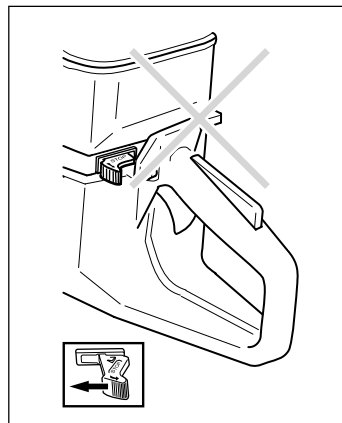

Start



WARNING! The cutting blade can rotate when the engine starts. Make sure it can rotate freely.

Take hold of the front handle using your left hand. Place your right foot on the lower section of the rear handle and press the power cutter against the ground.

Grip the starter with your right hand, and slowly pull the starter cord out until you feel some resistance (the pawls grip) now pull quickly and powerfully.

NOTE! Do not pull out the starter cord completely and do not release the starter from the fully extended position. This can damage the power cutter.

When the engine starts, quickly apply full throttle and the starter throttle catch will automatically disengage.

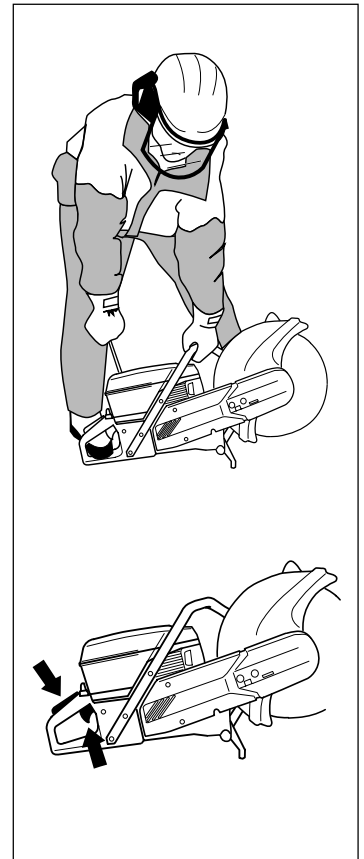

Stop

The engine is stopped by switching off the ignition. (Slide the stop switch to the right.)

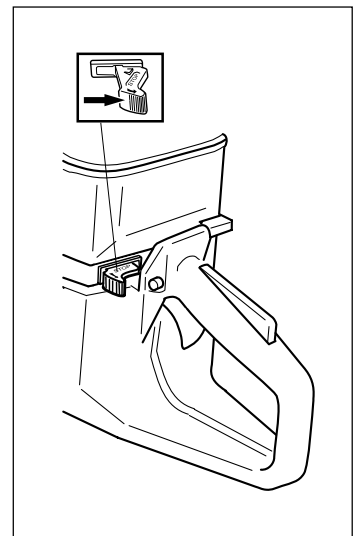

MAINTENANCE

Adjusting the drive belt

- The drive belt is fully enclosed and well protected from dust, dirt and mechanical effects during the cutting process.
- To tension the drive belt, slightly loosen the bolts (A), which secure the cutting head and belt guard.
- Turn the tensioning screw so that the nut (B) is located directly under the arrow on the cover. Shake the head to ensure the spring can tension the belt. The belt now automatically has the right tension.
- Tighten the bolts that hold the cutting head.

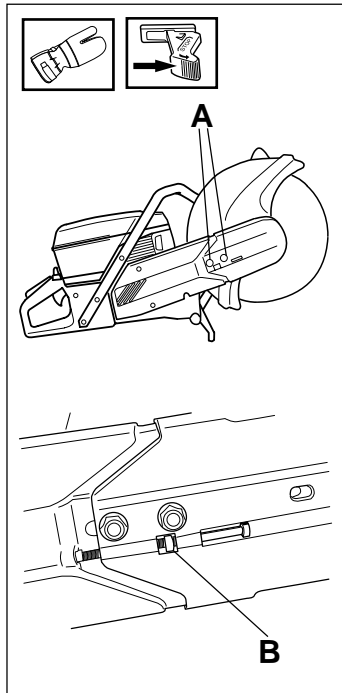

IMPORTANT INFORMATION! A new drive belt should be tensioned after using one or two tanks of fuel.

Changing the drive belt

- Loosen the two bolts (A).
- Turn the tensioning screw (B) until the tension has been released.
- Remove the two bolts (A).
- Remove the front belt cover (C).
- Remove the belt from the pulley.
- Dismantle the cutting head.
- Remove the nut (D). Remove the side cover.
- Replace the drive belt.
- To assemble reverse the procedure for dismantling.
- Check the blade guard for signs of cracking or other damage. Replace it if damaged.

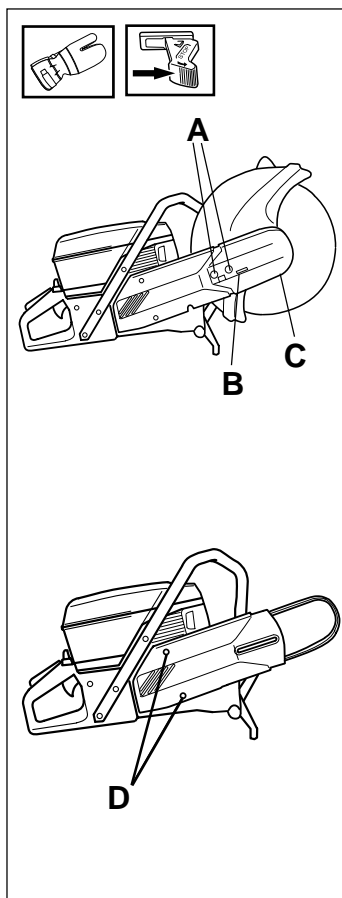

Belt pulley and clutch

Never start the engine when the belt pulley and clutch are removed for maintenance.



WARNING! Never use a power cutter without a blade guard over the cutting blade.

MAINTENANCE

Carburetor

Your Partner product has been designed and manufactured to specifications that reduce harmful emissions. After your unit has been run 8-10 tanks of fuel the engine has broken in. To ensure that your unit is at peak performance and producing the least amount of harmful emissions after break in, have your authorized servicing dealer, who has a revolution counter at his disposal, to check your carburetor for optimum operating conditions.

Functioning, Final setting



WARNING! Do not start the power cutter without the cutting arm or cutting head fitted. Otherwise the clutch can come loose and cause personal injury.

Operation

- The carburetor governs the engine speed via the throttle. Air/fuel are mixed in the carburetor

Jets

The carburetor is equipped with fixed jets to ensure the engine always receives the correct fuel air mixture.

If the engine lacks power or accelerates poorly do the following:

- Inspect or, if necessary, replace the air filter.
- If this does not help, contact an authorised service workshop.

Final setting of the idling speed T

Adjust the idling speed with the screw T. If it is necessary to re-adjust, first turn the idle speed adjusting screw T clockwise, until the blade starts to rotate. Then turn, counter-clockwise until the blade stops. A correctly adjusted idle speed setting occurs when the engine runs smoothly in every position. It should also be good margin to the rpm when the blade starts to rotate.

Recommended idling speed: 2 500 rpm.



Contact your servicing dealer, if the idle speed setting cannot be adjusted so that the blade stops. Do not use the power cutter until it has been properly adjusted or repaired.

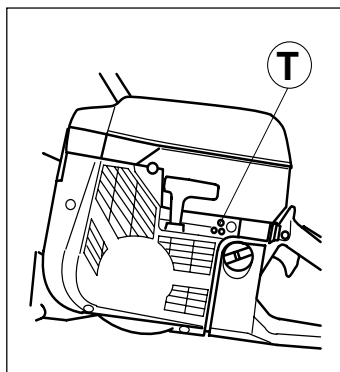

Fuel filter

- The fuel filter sits inside the fuel tank.
- The fuel tank must be protected from contamination when filling. This reduces the risk of operating disturbances caused by blockage of the fuel filter.
- The filter cannot be cleaned but must be replaced with a new filter when it blocked. **The filter should be changed at least once per year.**

Air filter

The air filter should be cleaned regularly removing dust and dirt to avoid:

- Carburettor malfunction
- Starting problems
- Reduced engine power
- Unnecessary wear to engine parts
- Abnormal fuel consumption



The air filter system consists of a main filter and a back-up filter:

1) The main-filter is an oiled foam filter that is easily accessible under the filter cover A. When used in dusty conditions, this filter should be checked/ replaced after every second tank of fuel. The filter must be cleaned and oiled regularly to obtain a satisfactory filtering effect. There is a special PARTNER oil produced for this purpose.

- Remove the filter. Wash the filter carefully in tepid, soapy water. After cleaning rinse the filter thoroughly in clean water. Squeeze out the filter and let the filter dry. **NOTE!** Compressed air at a high pressure can damage the foam.

- Oil the filter carefully. It is extremely important that the entire filter is saturated in oil.

2) The back-up filter is a paper filter and is accessible from under cover B. This filter should be changed/cleaned when the engine's output drops or after 1-2 weeks. The filter is cleaned by shaking or carefully using compressed air. Note the filter must not be washed!

A filter used for a long period of time can never be completely cleaned. Therefore all air filters must be replaced periodically with a new filter. **A damaged air filter must always be replaced.**

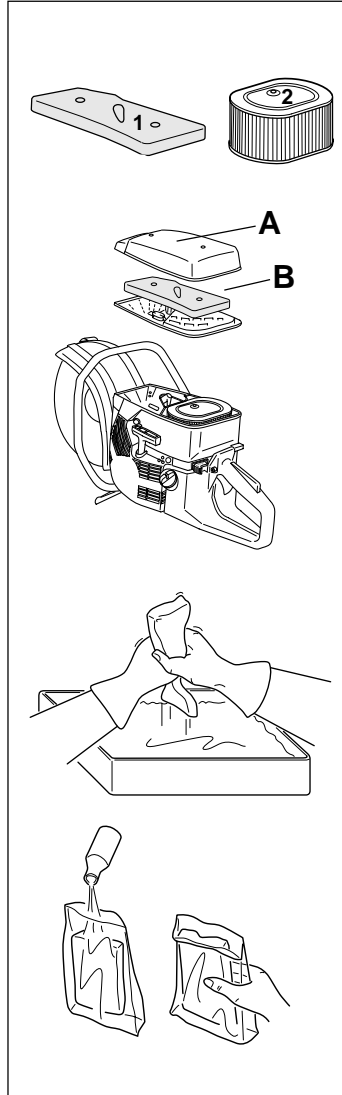

IMPORTANT INFORMATION!

Insufficient care of the air filter will cause deposits on the spark plug resulting in abnormal wear to engine parts.

MAINTENANCE

Starter



WARNING!

- The recoil spring sits in its tensioned position in the starter housing and can with careless handling fly out and cause personal injury.
- When replacing the recoil spring or the starter cord great care should be exercised. Always wear protective glasses.

Replacing a broken or worn starter cord



- Loosen the bolts that hold the starter against the crankcase and lift off the starter unit.
- Pull out the cord approx. 30 cm and lift it out of the cut-out in the starter-pulley's periphery. Reset the recoil spring by allowing the pulley to slowly rotate backwards.
- Loosen the screw in the centre of the starter-pulley and lift off the pulley. Insert and secure the starter cord in the starter pulley. Wind on approx. 3 turns of the cord on the pulley. Fit the pulley on the recoil spring so that the end of the recoil spring hooks on the pulley. Fit the screw in the centre of the pulley. Thread the starter cord through the hole in the starter housing and the starter handle. Tie a good knot on the end of the cord.

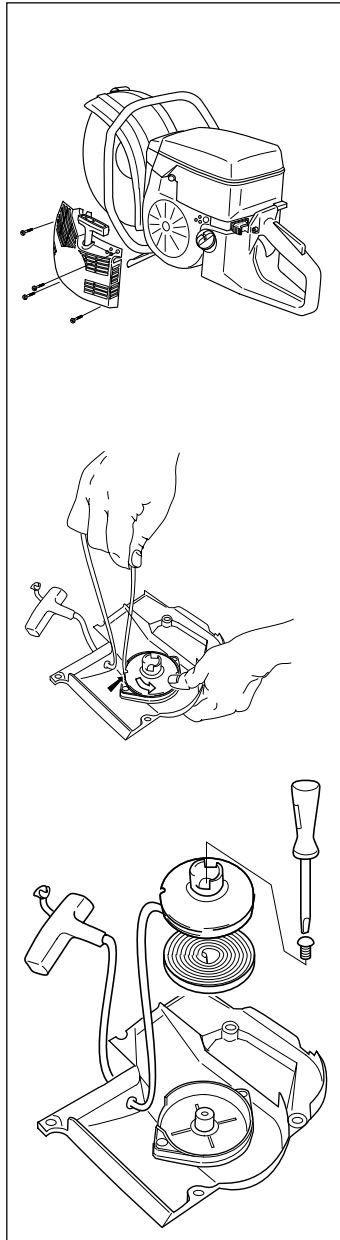

Tensioning the recoil spring

- Lift up the starter cord from the cut out on the pulley and turn the pulley approx. 2 turns clockwise.

NOTE! Ensure the starter pulley can be turned at least a further 1/2 turn when the starter cord is fully extended.

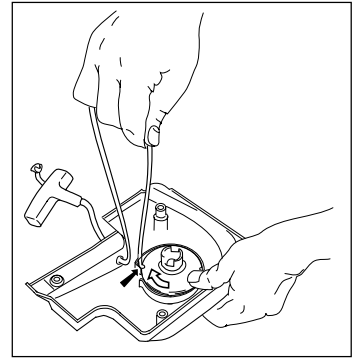

Replacing a broken recoil spring



- Lift the starter pulley (see "Changing a broken or worn starter cord").
- Loosen the screws holding the spring cassette.
- Disassemble the recoil spring by tapping the pulley (with its inside facing down) lightly against a working bench or similar. If the spring pops out when assembling, it should be mounted again, out and in towards the centre.
- Lubricate the recoil spring with thin oil. Assemble the starter pulley, and tension the recoil spring.

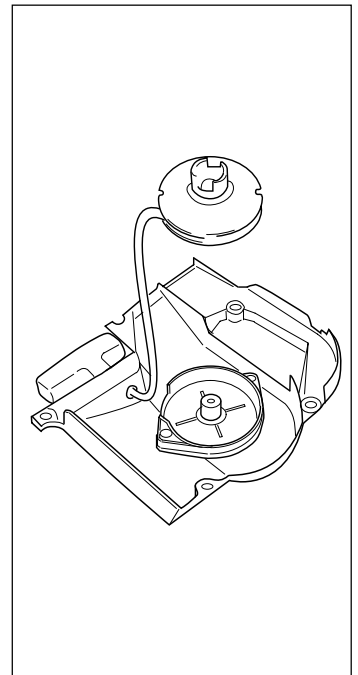

Fitting the starter

- Fit the starter by first pulling out the starter cord and then placing the starter in position on the crankcase. No slowly release the starter cord so that the pawls grip in the pulley.
- Fit and tighten the screws that hold the starter.

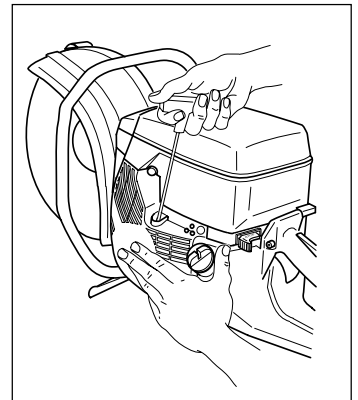

MAINTENANCE

Ignition system

IMPORTANT INFORMATION!

This power cutter has a green coloured ignition system with integrated speed governor (order no. 506 02 73-04). The machine may only be used with such a green coloured ignition system to prevent the risk of over revving.

Spark plug

The condition of the spark plug is affected by:

- An incorrect carburetor setting.
- An incorrect fuel mixture (too much oil).
- A dirty air filter.

These factors cause deposits on the spark plug electrode that may result in malfunction or starting difficulties.

- **If the machine is low on power, difficult to start or runs poorly while idling always check the spark plug first.** If the spark plug is dirty, clean it and at the same time check that the electrode gap is 0,5 mm (.020"). The spark plug should be changed after about one month of operation or earlier if necessary.

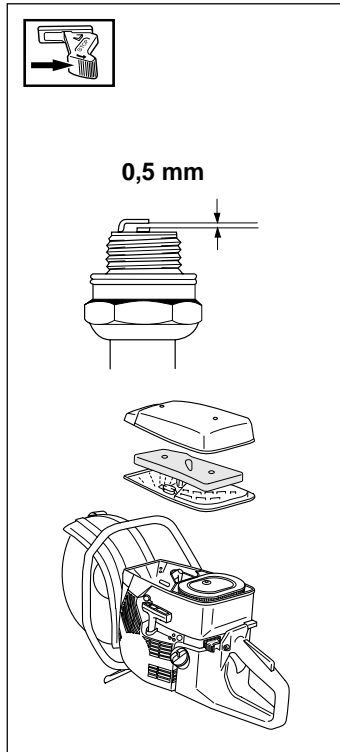

NOTE! Always use the recommended type of spark plug. (see chapter "Technical data")! An incorrect spark plug can damage the cylinder/piston.

Cooling system

To maintain as low an operating temperature as possible the power cutter is equipped with a cooling system.

The cooling system consists of:

1. An air intake on the starter unit.
2. Air flow guide.
3. Cooling fins on the flywheel.
4. Cooling fins on the cylinder.
5. Cylinder cover (leads cold air onto the cylinder).

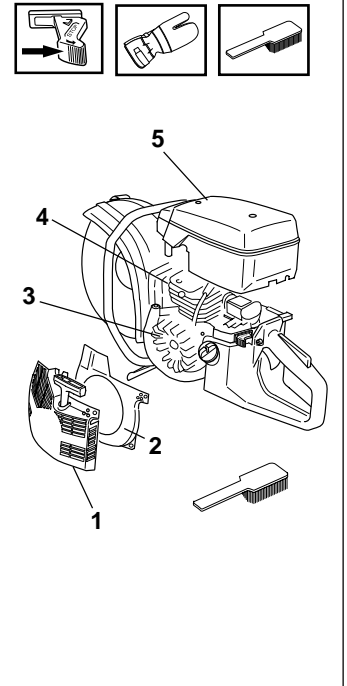

Clean the cooling system using a brush at least once a week, in difficult conditions more often. A dirty or blocked cooling system leads to the engine overheating resulting in damage to the cylinder and piston.

Muffler

The muffler is designed in order to reduce the noise level and to direct the exhaust gases away from the operator. The exhaust gases are hot and can contain sparks, which may cause fire if directed against dry and combustible material.

Never use a saw with a clogged or defective muffler.

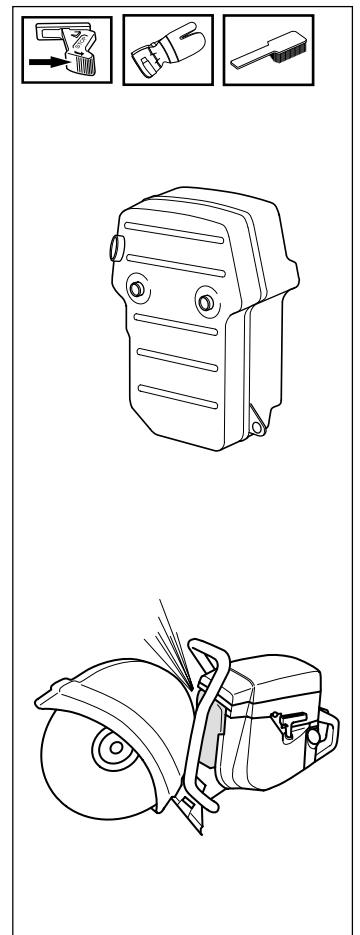

MAINTENANCE

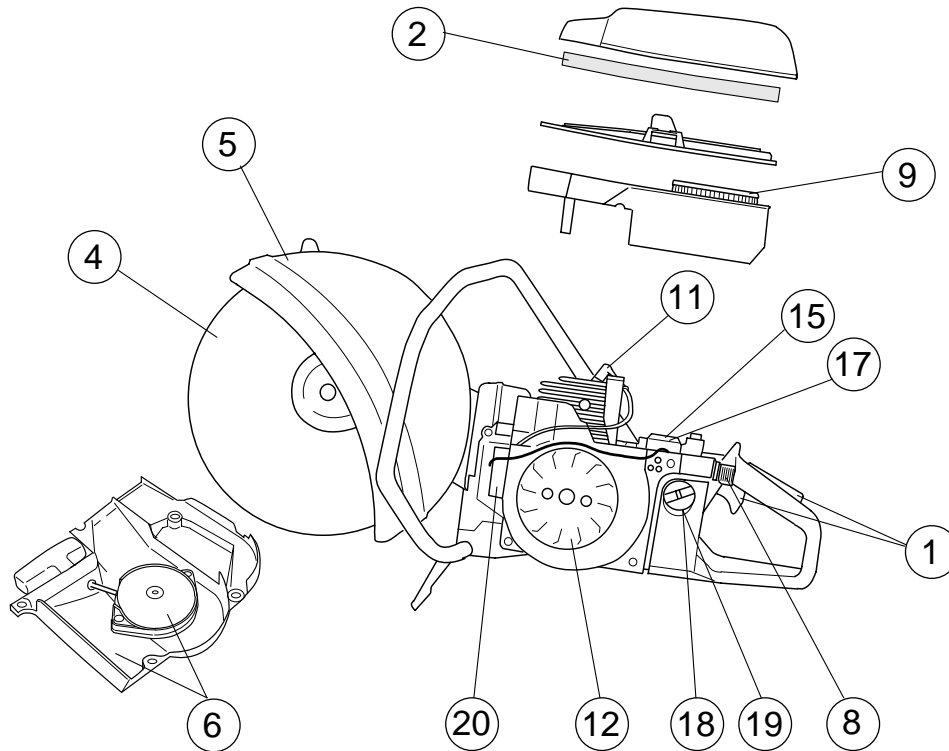

Below follows some general maintenance instructions.
If you need further information please contact your service workshop.

Daily maintenance

1. Check that throttle components work correctly from a safety view point (throttle and starter throttle catch).
2. Clean the main filter.
3. Check the tension of the drive belt.
4. Check the condition of the cutting blade.
5. Check the condition of the blade.
6. Check the starter and the starter cord; clean the outside of the starter's air intake.
7. Check that all nuts and bolts are tightened correctly.
8. Check the function of the stop switch.

Weekly maintenance

9. Check the back-up paper filter.
10. Check that the handles and the anti-vibration elements are not damaged.
11. Clean the spark plug. Check that the electrode gap is 0.5 mm.
12. Clean the cooling fins on the flywheel. Check the starter and recoil spring.
13. Clean the cooling fins on the cylinder.
14. Check the muffler.
15. Check the carburetor function.

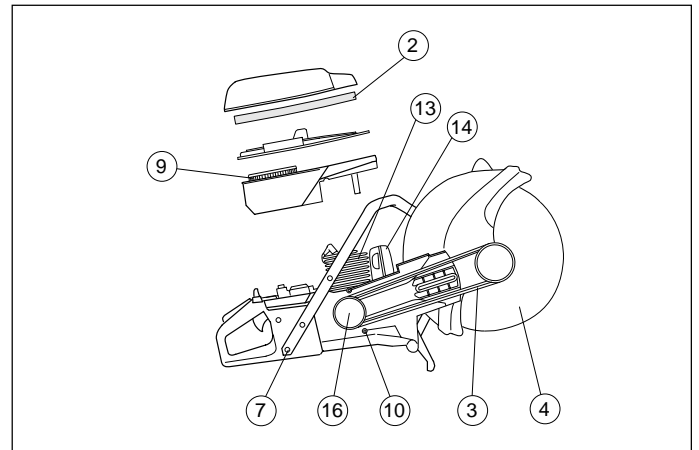

Monthly maintenance

16. Check the clutch drum, drive-pulley, and clutch springs with regard to wear.
17. Clean the outside of the carburetor
18. Check the fuel filter, fuel hose, change if necessary.
19. Clean the inside of the fuel tank.
20. Check all cables and connections.

TECHNICAL DATA

Engine

Cylinder volume, cm ³ /cu.in	93,6/5,7
Cylinder bore, mm/inch	∅ 56/2,2"
Stroke, mm/inch	38/1,5"
Idle speed, rpm	2 500 rpm
Recommended max. speed, unloaded, rpm	9 800 ± 300
Power, kW	4,5

Ignition system

Manufacturer	FHP
Type of ignition system	CD
Spark plug	Champion RCJ-7Y
Electrode gap, mm/inch	0,5 (.020")

Fuel and lubrication system

Manufacturer	Tillotson
Carburetor type	HS 282A
Fuel capacity, litre/US Pint	1,0/2,65

Weight

Without fuel and cutting blade, kg/Lbs	
12" (∅ 300 mm)	9,9/21,8
14" (∅ 350 mm)	10,3/22,7
16" (∅ 400 mm)	11,2/24,7

Cutting equipment

Cutting blade	Gear ratio	Max. peripheral speed
12"	0,52	80 m/s
14"	0,52	100 m/s
16"	0,42	100 m/s





WARNING!

Some dust created by power sanding, sawing, grinding, drilling and other construction activities contains chemicals known (to the State of California) to cause cancer, birth defects or other reproductive harm. Some examples of these chemicals are:

- Lead from lead-based paints
- Crystalline silica from bricks and cement and other masonry products
- Arsenic and chromium from chemically-treated lumber

Your risk from these exposures varies, depending on how often you do this type of work. To reduce your exposure to these chemicals: work in a well ventilated area, and work with approved safety equipment, such as those dust masks that are specially designed to filter out microscopic particles.

PARTNER[®]

108 88 04-95



2000W51