

PX-3 PAVER XTREME

OWNERS MANUAL



DRY PAVER SAW
OWNER'S MANUAL &
OPERATING INSTRUCTIONS

CAUTION

READ SAFETY
AND GENERAL
INSTRUCTIONS
CAREFULLY
BEFORE USING
SAW FOR THE
FIRST TIME



SERIAL NUMBER

YOU SHOULD RECORD THE SERIAL NUMBER OF YOUR SAW ON THIS OWNER'S MANUAL AND ON THE WARRANTY CARD, WHICH MUST BE SENT IN, TO BE EFFECTIVE. BE SURE TO INCLUDE ALL PERTINENT INFORMATION REQUIRED.

MK DIAMOND PRODUCTS, INC
1315 STORM PARKWAY
TORRANCE, CA 90509-2803
310-539-5158
www.mkdiamond.com

Part No. 160445
Revision 01/04

SAFETY INSTRUCTIONS FOR THE PX-3 PAVER SAW

Congratulations on your purchase of a PX-3 Paver Saw. We are certain that you will be pleased with your purchase. MK Diamond takes pride in producing the finest construction power tools and diamond blades in the industry.

Operated correctly, your PX-3 should provide you with years of service. In order to help you, we have included this manual. This owners manual contains information necessary to operate and maintain your PX-3 safely and correctly. Please take a few minutes to familiarize yourself with the PX-3 by reading and reviewing this manual.

If you should have questions concerning your PX-3 , please feel free to call our friendly customer service department at: 800 421-5830

Regards,

MK Diamond

SAFETY

SAFETY MESSAGES	4
DAMAGE PREVENTION AND INFORMATION MESSAGES	4
GENERAL SAFETY PRECAUTIONS AND HAZARD SYMBOLS	4
CALIFORNIA PROPOSITION 65 MESSAGE	6
ELECTRICAL REQUIREMENTS AND GROUNDING INSTRUCTIONS	8
SAFETY LABEL LOCATIONS	10
PAVER SAW SPECIFIC WARNINGS	10
PRODUCT SPECIFICATIONS	11

UNPACKING, TRANSPORT, STAND and ASSEMBLY

UNPACKING	12
CONTENTS	12
TRANSPORT	12
ASSEMBLY	13

SETUP, ADJUSTMENT & OPERATION

SETUP	14
PRE-START INSPECTION	14
ADJUSTMENT & OPERATION	15
CLEANUP	17

MAINTENANCE AND TROUBLESHOOTING

MAINTENANCE	18
TROUBLESHOOTING	22

EXPLODED VIEW AND PARTS LIST

EXPLODED VIEW	23
PARTS LIST	24

THEORY

THEORY OF DIAMOND BLADES	26
--------------------------------	----

ACCESSORIES

ACCESSORIES	27
-------------------	----

ORDERING & RETURN INSTRUCTIONS

ORDERING INFORMATION	28
RETURN MATERIALS POLICY	28
PACKAGING INSTRUCTIONS	28
AUTHORIZED SERVICE CENTERS	28

MK Diamond may have patents, patent applications, trade marks, copyrights of other intellectual property right covering this product in this document.

SAFETY

Read and follow all safety, operating and maintenance instructions. Failure to read and follow these instructions could result in injury or death to you or others. Failure to read and follow these instructions could also result in damage and/or reduced equipment life.

SAFETY MESSAGES:

Safety messages inform the user about potential hazards that could lead to injury, death and/or equipment damage. Each safety message will be preceded by one of the following (3) three words that identify the severity of the message.



DANGER

Not following instructions WILL lead to DEATH or SERIOUS INJURY



WARNING

Not following instructions COULD lead to DEATH or SERIOUS INJURY



CAUTION

Not following instructions CAN lead to injury.

DAMAGE PREVENTION AND INFORMATION MESSAGES:

A Damage Prevention Message is to inform the user of important information and/or instructions that could lead to equipment or other property damage if not followed. Information Messages convey information that pertains to the equipment being used. Each message will be preceded by the word NOTE, as in the example below.

NOTE: Equipment and/or property damage may result if these instructions are not followed.

GENERAL SAFETY PRECAUTIONS AND HAZARD SYMBOLS:

In order to prevent injury, the following safety precautions and symbols should be followed at all times!

Safety Precautions:



READ OWNERS MANUAL BEFORE USE



Before using this equipment, ensure that the person operating this machine has read and understands all of the instructions in the manual. Precaution is the best insurance against accidents. Read and understand all safety precautions, messages, warnings and hazard symbols. You are responsible for your own safety.



KEEP GUARDS IN PLACE



Adhere to safety guidelines: ANSI American National Standards Institute, OSHA, or local Regulations. Never operate the saw with out the guards in place!



REMOVE ADJUSTING KEYS AND WRENCHES

Form a habit of checking to see that keys and adjusting wrenches are removed from the power tool before it is turned on.



KEEP WORK AREA CLEAN

Cluttered work areas and benches invite accidents.



DO NOT USE IN DANGEROUS PLACES

Do not use power tools in damp or wet locations nor expose them to rain. Always keep the work area well lighted.



KEEP CHILDREN AWAY

All visitors and children should be kept a safe distance from work area.

 MAKE THE WORKSHOP KID PROOF

Make the workshops kid proof by using padlocks, master switches or by removing starter keys.

 DO NOT FORCE THE TOOL

A power tool will do a job better and safer operating at the rate for which it was designed.

 USE THE RIGHT TOOL

Do not force a tool or an attachment, to do a job that it was not designed to do.

 USE THE PROPER EXTENSION CORD

If using an extension cord make sure it is in good condition first. When using an extension cord, be sure to use one heavy enough to carry the electrical current your product will draw. An undersized extension cord will cause a drop in line voltage that will result in a loss of power and overheating. TABLE 1, Page 9 shows the correct AWG size to use depending on cord length and nameplate ampere rating. If in doubt, use the next heavier gage. The smaller the gage number, the heavier the cord.

 USE PROPER APPAREL

Do not wear loose clothing, gloves, neckties, rings, bracelets, or other jewelry that may be caught in moving parts. Non-slip footwear is recommended. Wear protective hair covering to contain long hair.

 ALWAYS USE SAFETY GLASSES

Safety glasses should always be worn when working around power tools. In addition, a face, dust mask or respirator should be worn if a cutting operation is dusty. Everyday eyeglasses only have impact resistant lenses and may not prevent eye injury—they are NOT safety glasses.

 SECURE WORK

Clamps or a vise should be used to hold work whenever practical. Keeping your hands free to operate a power tool is safer.

 DO NOT OVERREACH

Keep proper footing and balance at all times by not overreaching.

 MAINTAIN TOOLS WITH CARE

Keep tools clean for the best and safest performance. Always follow maintenance instructions for lubricating, and when changing accessories.

 DISCONNECT TOOLS

Power tools should always be disconnected before servicing or when changing accessories, such as blades, bits, cutters, and the like.

 REDUCE THE RISK OF UNINTENTIONAL START

Make sure the ON/OFF switch is in the OFF position before plugging in a power tool.

SAFETY



USE RECOMMENDED ACCESSORIES

Consult the owner's manual for recommended accessories. Using improper accessories may increase the risk of personal or by-stander injury.



NEVER STAND ON THE TOOL

Serious injury could occur if a power tool is tipped, or if a cutting tool is unintentionally contacted.



CHECK FOR DAMAGED PARTS

Before using a power tool, check for damaged parts. A guard or any other part that is damaged should be carefully checked to determine it would operate properly and perform its intended function. Always check moving parts for proper alignment or binding. Check for broken parts and mountings and all other conditions that may affect the operation of the power tool. A guard, or any damaged part, should be properly repaired or replaced.



DIRECTION OF FEED

Always feed work into a blade or cutter against the direction of rotation. A blade or cutter should always be installed such that rotation is in the direction of the arrow imprinted on the side of the blade or cutter.



NEVER LEAVE A TOOL UNATTENDED

TURN POWER OFF - Do not leave a tool until it comes to a complete stop. Always turn a power tool OFF when leaving the work area, or, when a cut is finished.

CALIFORNIA PROPOSITION 65 MESSAGE:



WARNING

Some dust created by power sanding, sawing, grinding, drilling, and other construction activities contain chemicals known [to the State of California] to cause cancer, birth defects or other reproductive harm. Some examples of these chemicals are:

- Lead, from lead-based paints
- Crystalline silica, from bricks and cement and other masonry products and
- Arsenic and chromium, from chemically treated lumber

For further information, consult the following sources:

<http://www.osha-slc.gov/sltc/silicacrystalline/index.html>

http://www.oehha.org/prop65/out_of_date/6022kLstA.html

Your risk from these exposures varies depending on how often you do this type of work. To reduce your exposure to these chemicals, work in a well-ventilated area, and work with approved safety equipment, such as those dust masks that are specially designed to filter out microscopic particles.

Hazard Symbols: **Electrical Shock!**

Never touch electrical wires or components while the engine is running. They can be sources of electrical shock which could cause severe injury or burns.

 **Rotating Parts!**

Keep hands, feet, hair, and clothing away from all moving parts to prevent injury. Never operate the engine with covers, shrouds, or guards removed.

 **Over Speed!**

Never tamper with the governor components or settings to increase the maximum speed. Severe personal injury and damage to the engine or equipment can result if operated at speeds above maximum.

 **WARNING** Sawing and drilling generates dust. Excessive airborne particles may cause irritation to eyes, skin and respiratory tract. To avoid breathing impairment, always employ dust controls and protection suitable to the material being sawed or drilled; See OSHA (29 CFR Part 1910.1200). Diamond Blades improperly used are dangerous. Comply with American National Standards Institute Safety Code, B7.1 and, Occupational Safety and Health Act covering Speed, Safety Guards, Flanges, Mounting Procedures, General Operating Rules, Handling, Storage and General Machine Conditions

SAFETY

ELECTRICAL REQUIREMENTS AND GROUNDING INSTRUCTIONS:

In order to prevent potential electrical shock and injury, the following electrical safety precautions and symbols should be followed at all times!

WARNING



In case of a malfunction or breakdown, grounding provides a path of least resistance for electric current to reduce the risk of electric shock. This tool is equipped with an electric cord having an equipment-grounding conductor and a grounding plug. The plug must be plugged into a matching outlet that is properly installed and grounded in accordance with all local codes and ordinances.

- Do not modify the plug provided – if it will not fit the outlet; have the proper outlet installed by a qualified electrician
- Improper connections of the equipment-grounding conductor can result in a risk of electric shock. The equipment-grounding conductor is the insulated conductor that has an outer surface that is green, with or without yellow stripes. If repair or replacement of the electric cord or plug is necessary, do not connect the equipment-grounding conductor to a live terminal
- Check with a qualified electrician or service personnel if the grounding instructions are not completely understood, or if in doubt as to whether the tool is properly grounded
- Use only 3-wire extension cords that have 3-prong grounding plugs and 3-pole receptacles that accept the tool's plug
- Repair or replace a damaged or worn cord immediately

WARNING



This tool is intended for use on a circuit that has an outlet that looks like the one shown in Sketch A of Figure 1. The tool has a grounding plug that looks like the plug illustrated in Sketch A of FIGURE 1. A temporary adapter, which looks like the adapter illustrated in sketches B and C, may be used to connect

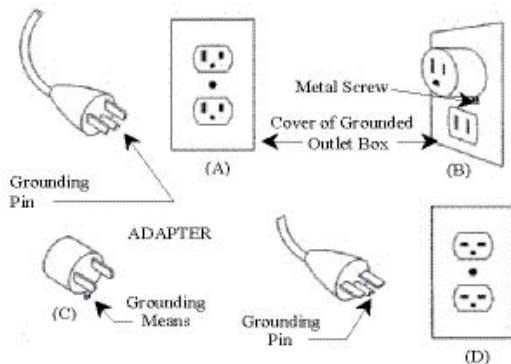

this plug to a 2-pole receptacle as shown in Sketch B, if a properly grounded outlet is not available. The temporary adapter should be used only until a properly grounded outlet can be installed by a qualified electrician. The green-colored rigid ear, lug, and the like, extending from the adapter, must be connected to a permanent ground such as a properly grounded outlet box.

Use of a temporary adapter is not permitted in Canada

NOTE:

FIGURE 1

WARNING



To reduce the risk of electrocution, keep all connections dry and off the ground.

Use only extension cords that are intended for outdoor use. These extension cords are marked "Acceptable for use with outdoor appliances; store indoors while not in use." Use only extension cords having an electrical rating not less than the rating of the product. Do not use damaged extension cords.

Examine extension cords before using and replace if damaged. Do not abuse extension cords and do not yank on any cord to disconnect. Keep cords away from heat and sharp edges. Always disconnect the extension cord from the receptacle before disconnecting the product from the extension cord.

⚠ WARNING

Use of under size extension cords result in low voltage to the motor that can result in motor burnout and premature failure. MK Diamond warns that equipment returned to us showing signs of being run in a low voltage condition, through the use of undersized extension cords will be repaired or replaced totally at the customers expense. There will be no warranty claim.

To choose the proper extension cord,

- Locate the length of extension cord needed in TABLE 1 below.
- Once the proper length is found, move down the column to obtain the correct AWG size required for that length of extension cord.

Extension Cord Minimum Gage for Length				
Volts	Total Length of Cord in Feet			
120 V	25 ft.	50 ft.	100 ft.	150 ft.
	AWG	AWG	AWG	AWG
	14	12	Not Recommended	

TABLE 1

SAFETY

SAFETY LABEL LOCATIONS

Safety labels are located according to TABLE 2 below. The labels contain important safety information. Please read the information contained on each safety label. These labels are considered a permanent part of your saw. If a label comes off or becomes hard to read, contact MK Diamond or your dealer for a replacement

Item	Description	Part No.
1	Proposition 65 Warning Label	158322
2	Extension Cord Warning Label	155672
3	Safety Caution Label	155576

TABLE 2: SAFETY LABEL LOCATIONS

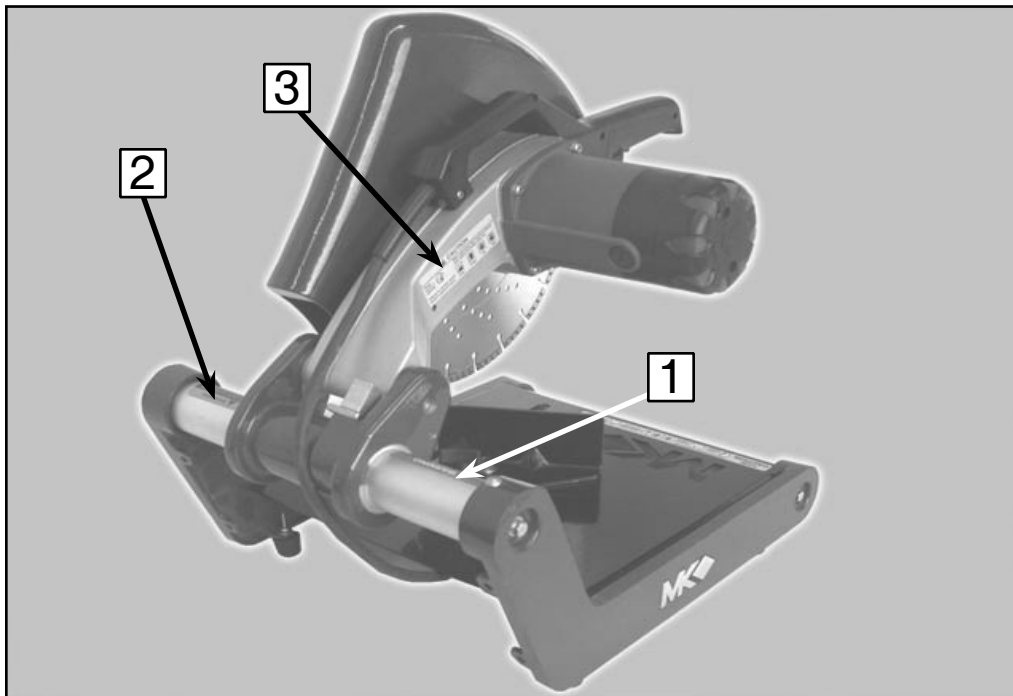

PAVER SAW SPECIFIC WARNINGS:



WARNING

Wear eye protection.

Disconnect saw before servicing, when changing cutting blades, and cleaning.

Replace damaged cutting blade before operating.

PRODUCT SPECIFICATIONS

The PX-3 is a versatile lightweight, dry, masonry saw. Operated and used according to this manual, the PX-3 will provide years of dependable service.

General Description

The PX-3 Paver Xtreme is engineered as a 14" dry saw, consisting of a powerful 115v motor in a hard plastic case. The saw has a five (5) inch cutting depth.

Motor Specifications

Motor specifications for the PX-3 are listed in TABLE 3 below.

Voltage	115V
Overall Amperage	13 A
Frequency	60Hz
RPM	3500 rpm

Table 3

Blade Capacity:

The PX-3 uses a specially designed 14-inch diameter segmented dry MK Diamond blade with a 0.110 in. cutting width.

Paver Types:

The PX-3 can cut a variety of masonry types including slump stone block, wall brick, paver brick, roofing tile, marble, granite, decorative rock, or almost any other non-ferrous material.

Lockable Trigger Switch:

The PX-3 is designed with a lockable trigger-operating switch in the handle to allow for ease of operation.

Removable Motor Air Filter

The PX-3 is designed with an easy clean motor air filter to extend the life of the motor.

Replaceable Motor Brushes:

The PX-3 is designed with replaceable motor brushes to extend operating life.

Dust Collector:

The PX-3 is designed with a Dust Collector nozzle that can be used to remove dust from the Cutting Area, using your shop vacuum's 2-1/2 inch diameter hose.

NOTE: The PX-3 is not designed to cut plastic or ferrous (metals) material.

UNPACKING, TRANSPORT, STAND and ASSEMBLY

UNPACKING

Your PX-3 has been shipped from the factory thoroughly inspected. Only minimal assembly is required.

If not already done, remove the PX-3 from the carton and place it on a flat surface. Remove strapping.

Remove the accessories box from the main carton and place along side the PX-3. Note: The Owners Manual is in the accessories box.

CONTENTS

In the PX-3 packaging containers you will find:

- PX-3 Dry Paver Saw
- One 14 inch Segmented Dry Diamond Blade (or Segmented Block Blade)
- One Replacement Motor Air Filter
- One Dust Nozzle
- One Blade Wrench
- One Shaft Wrench
- One Owner's Manual
- One Warranty Card



PX-3

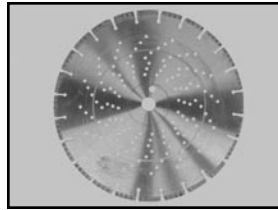

Segmented Dry
Diamond Blade

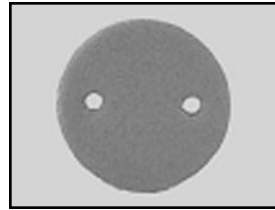

Replacement Motor
Air Filter

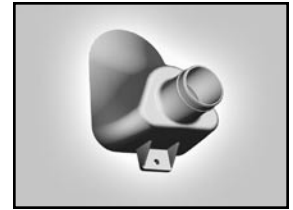

Dust
Nozzle

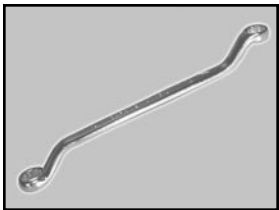

Blade Wrench



Shaft Wrench



Owner's Manual



Warranty Card

TRANSPORT:

- CAUTION**
1. The PX-3 weighs approximately thirty five (35) pounds, making transport easy.
 2. Always observe safe lifting practices when lifting the PX-3

NOTE: Lock the Cutting Head in the DOWN position using the Locking Pin when transporting the PX-3

Due to its lightweight construction, the PX-3 is designed to be carried by the durable aluminum frame. Simply lock the spring assisted cutting head in the DOWN position, grasp the frame by the lower front and upper back cross members, then lift and transport the PX-3 to the desired work location.

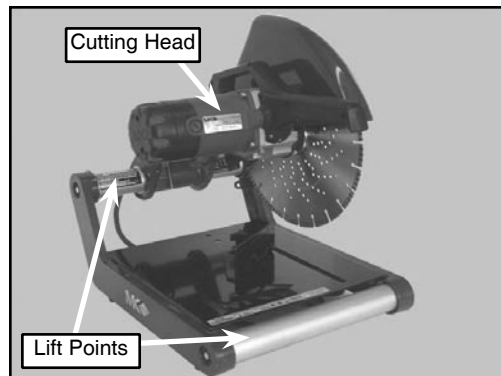

UNPACKING, TRANSPORT, UNIVERSAL STAND and ASSEMBLY

ASSEMBLY:

Follow the assembly instructions to prepare your PX-3 for operation.

1. Diamond Blade Installation

NOTE: When installing the Retaining Screw, do not "cross-thread" and DO NOT over tighten the screw.

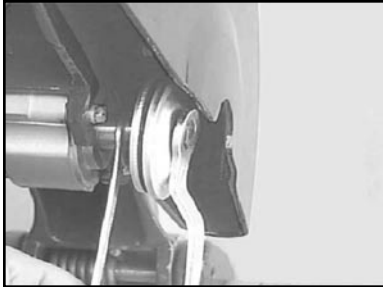

(A)
Identify Blade Retaining
Screw and Outer Flange.

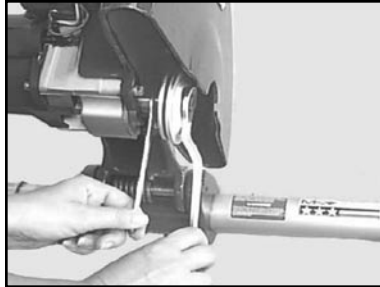

(B)
Remove Blade Retaining
Screw and Outer Flange.



(C)
Install and seat Blade –verify
rotation.

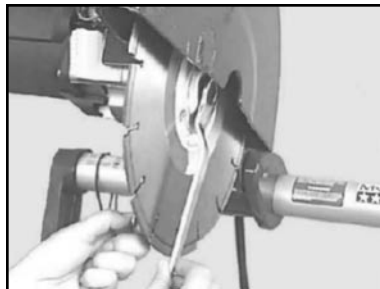

(D)
Install Blade Retaining Screw
and Outer Flange – tighten.

2. Dust Nozzle

The PX-3 Dust Nozzle assists on the removal of dust and debris from the cutting area. Its shape is designed so it directs the flow of these particles to the shop vac hose (NOT INCLUDED). The hose required is a 2-1/2" in diameter. Connect the hose from your shop vac (NOT INCLUDED) to the Dust Collector Outlet located at the rear of the PX-3 Cutting Area.

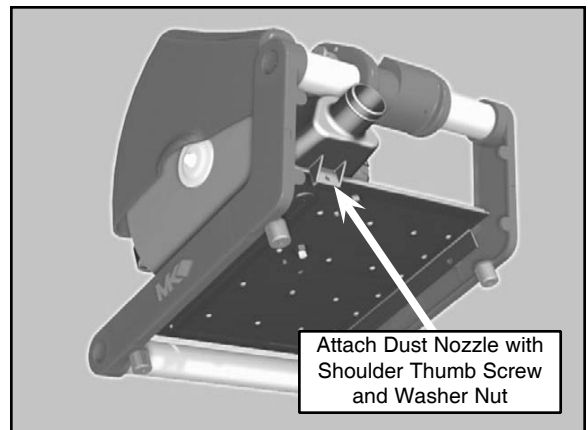
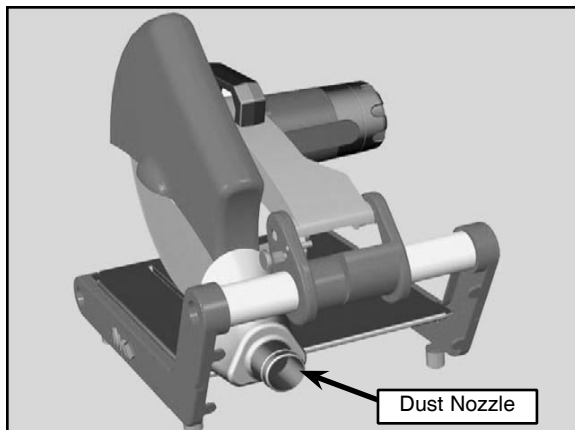

SETUP, ADJUSTMENT & OPERATION

SETUP:

- CAUTION** • Before powering or starting, check for damage that could prevent this equipment from proper operation or performing its intended function. Check for binding and alignment of moving parts. Check for damaged, broken, or missing parts.
- Verify the trigger switch-locking button is in the RELEASE position.
- Before connecting the PX-3 to a power supply, be sure the voltage, cycle and phase of the job site power source meet the following requirements:

VOLTAGE	115V
CYCLE	60Hz
PHASE	1-phase

TABLE 3

- If using an extension power cord, make sure the length and wire gauge corresponds to the requirements listed in TABLE 1 on page 9 . An extension power cord that is too small in wire gauge (diameter), or too long in length, will cause the motor to overheat and could cause premature failure.
- Do not cover the motor vents. This could lead to motor overheating.

Portable Generator:

If using a portable generator to provide power, ensure the generator meets the following minimum requirements:

8kW	120/240	66.7/33.3 Amps	Single Phase
-----	---------	----------------	--------------

PRE-START INSPECTION

The pre-start inspection should be performed before beginning any job.

NOTE: In order to avoid breaker tripping, a 20-amp circuit breaker should be used.

CAUTION If the Diamond Blade shows signs of fatigue cracking, replace the Blade before starting work. (See Diamond Blade Change-Out section on Page)

1. Inspect the Blade for damage. Verify the Blade is correct for the material being cut.
2. Inspect the PX-3 for damage.
3. Inspect the Motor Air Filter for cleanliness.
4. Verify the Trigger Switch is unlocked.
5. Plug the Power Cord into a power source.

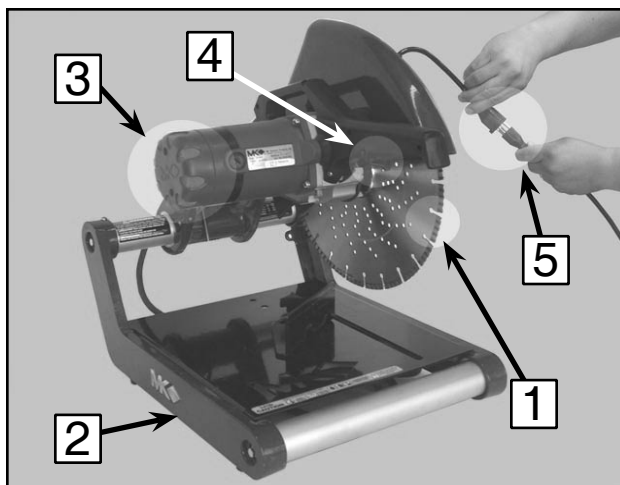

SETUP, ADJUSTMENT & OPERATION

ADJUSTMENT & OPERATION

Chop Cutting:

A chop cut is performed by cutting completely through an object in one pass. The following section describes the correct procedure for performing a chop cut.

1. Position the Back Stop for a cross cut or rip cut.
2. Position the work against back stop.
3. Depress the Trigger Switch to start. Lower the Cutting Head to begin cutting.
4. Continue lowering the Cutting Head until the cut is complete.
5. When cutting is complete, raise the Cutting Head and release the Trigger Switch.

CAUTION Allow the Blade to stop moving before removing work

6. Remove work from the cutting area.

Cross Cutting:

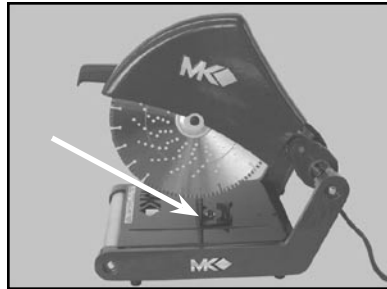

Back Stop in Forward position for Cross Cut

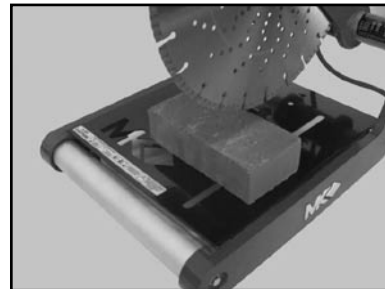

Position work against back stop and perform the Cut

Rip Cutting:

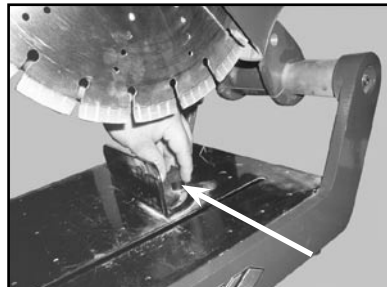

Loose knob



Loose wingnut located underneath the table



Position Back Stop in Backward Location and tighten both the knob and wing nut



Position work against back stop as shown and perform the cut

SETUP, ADJUSTMENT & OPERATION

Angle Cutting:

Angle cuts are performed using the chop cut method. For angle cuts the Adjustable Back Stop is removed and repositioned. The following section describes the correct procedure for performing an angle cut.

1. Remove and position the Adjustable Back Stop.
2. Position the Back Stop for an angle cut.
3. Position the work below the Cutting Head.
4. Depress the Trigger Switch to start. Lower the Cutting Head to begin cutting.
5. Continue lowering the Cutting Head until the cut is complete.
6. When cutting is complete, raise the Cutting Head and release the Trigger Switch.

CAUTION Allow the Blade to stop moving before removing work

7. Remove work from the cutting area.

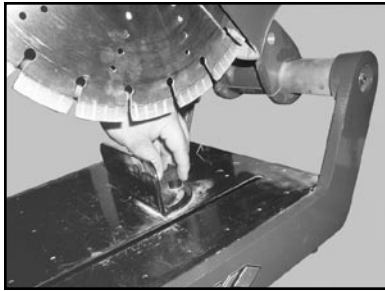

(A)
Loose the knob

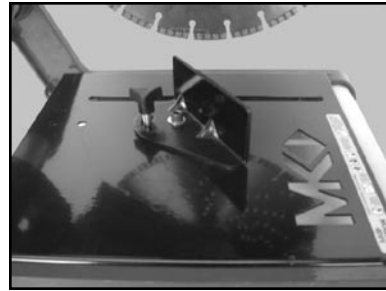

(B)
Pivot the back stop to the
desired angle

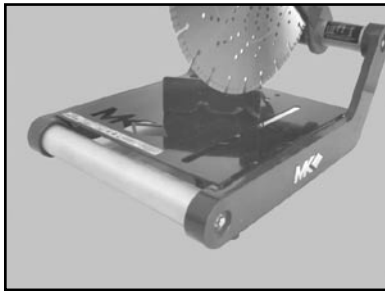

(C)
Now the back stop is ready

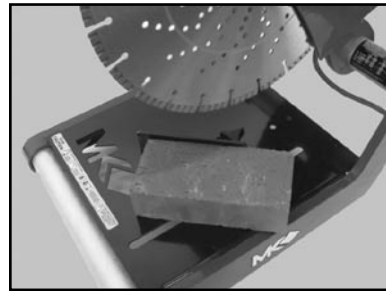

(D)
Place work against the back
stop and perform the cut

SETUP, ADJUSTMENT & OPERATION

CLEANUP

Clean the Air Filter and PX-3 surfaces after each use. The following section describes the correct procedure for cleaning your PX-3.

1. Unplug the PX-3 from its power source.
2. Remove the Motor Filter Cap. The Filter Cap pops on and off without removing the retaining screws.
3. Clean the Filter by removing it from the Filter Cap and tapping it on a hard surface, or use compressed air.

⚠ CAUTION Always wear eye protection when using compressed air.

4. Reinstall Filter into Filter Cap and replace it on the PX3 Motor.
5. Clean the remainder of the PX-3 by wiping its surfaces with a clean cloth.



(A)
Unplug the PX-3 from
Power Source

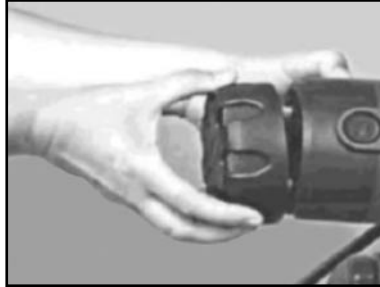

(B)
Remove Motor
Filter Cap

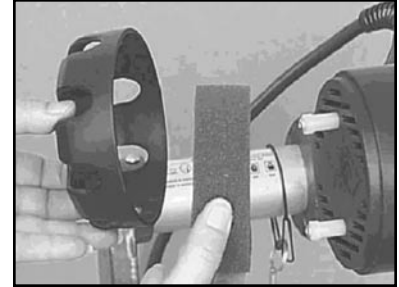

(C)
Remove Filter



(D)
Clean up Filter by tapping
it on a hard surface or use
compressed air.

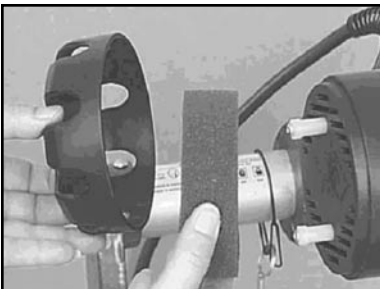

(E)
Reinstall Filter into Filter Cap
and place them back on to the
PX-3 unit



(E)
Clean the remainder of
the PX-3

MAINTENANCE AND TROUBLESHOOTING

MAINTENANCE

General Maintenance

It is important to lubricate the Cutting Head Torsion Spring after each use. Use light oil such as WD-40 or 3-in-1 when lubricating parts.

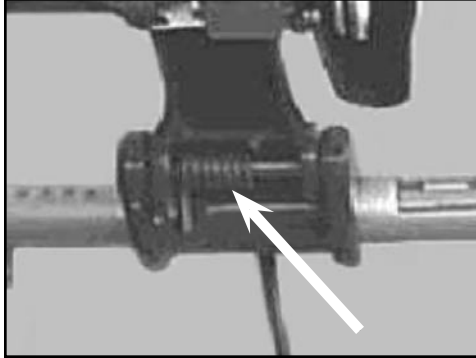

Lubricate Torsion Spring

Monthly Maintenance:

The following maintenance should be performed Monthly. Items should be inspected as described below.

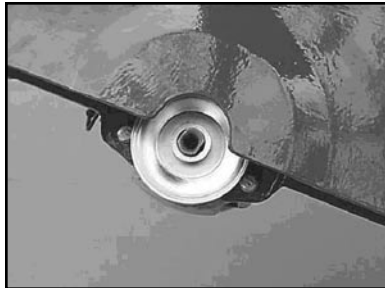

(A)
Clean and inspect the Inner Flange and Motor Shaft

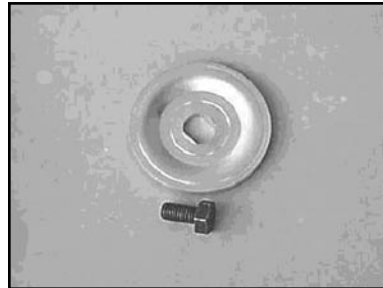

(B)
Clean the Blade Retaining Screw

MAINTENANCE AND TROUBLESHOOTING

BLADE DRESSING

Like most cutting instruments, a Diamond Blade performs best when it is dressed. Over time and use, diamonds on the outer edge will become smooth or “glazed” over. This will reduce grinding efficiency and may cause the blade to “wander” or bend, giving the illusion of an alignment problem. When this occurs, the blade will need to be dressed. The diamond blade can be dressed using the MK Dressing Stick (part number 152792) and by following the steps below.

1. Set up the PX-3 for operation.
2. Position the Back Stop to accommodate the Dressing Stick.
3. Hold the Dressing Stick in position and depress the Trigger to start. Lock if desired.
4. Lower the Cutting Head while pushing the Dressing Stick into the Blade.

⚠ CAUTION Allow the Blade to stop moving before removing work

5. Repeat the cut stroke eight (8) times.
6. When the Blade is dressed, release the Trigger Switch and raise the Cutting Head. Allow Blade to stop moving before removing the Dressing Stick.



(A)
Set up the PX-3 for operation



(B)
Position the Back Stop to accommodate the Dressing Stick

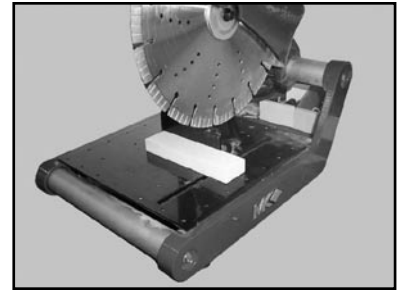

(C)
Place Dressing Stick and perform cut, repeat cut eight (8) times

MAINTENANCE AND TROUBLESHOOTING

DIAMOND BLADE CHANGE OUT

Change the Diamond Blade when it becomes worn, cracked, or damaged. The following section describes the correct procedure for changing out the Diamond Blade.

WARNING



Disconnect the tool before servicing and when changing accessories, such as blades, bits, cutters, and the like.



(A)
Unplug the PX-3 from its
Power Source

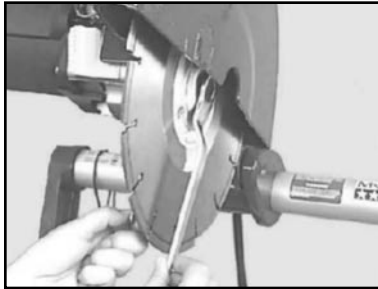

(B)
Remove Retaining Nut and
Outer Flange

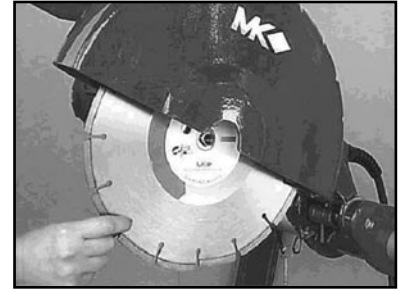

(C)
Remove Diamond Blade from
Blade Shaft



(D)
Install the Diamond Blade
onto Blade Shaft. Ensure that
it is seated properly on the
Flange.

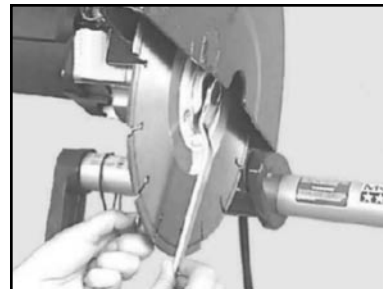

(E)
Install the Retaining Nut and
Outer Flange and then tighten
using the Blade and Shaft
Wrenches

MOTOR BRUSH CHANGE-OUT

WARNING



Disconnect the tool before servicing and when changing accessories, such as blades, bits, cutters, and the like.

1. Unplug the PX-3 from its power source and set it up for operation (See Setup, Adjustment and Operation)

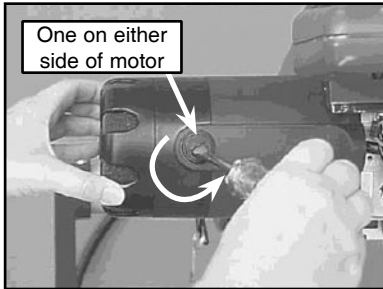

(A)
Locate and remove one Motor Brush Cap

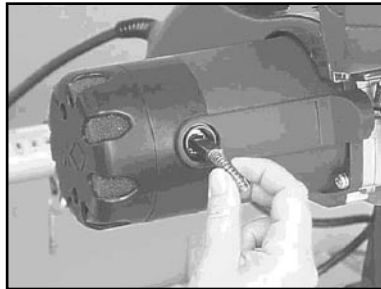

(B)
Remove the Motor Brush.
Clean the Brush Housing



(C)
Align and install the new Motor Brush

NOTE: When installing Motor Brushes, care must be taken to ensure the Spring End is straight before installing the Motor Brush Cap.

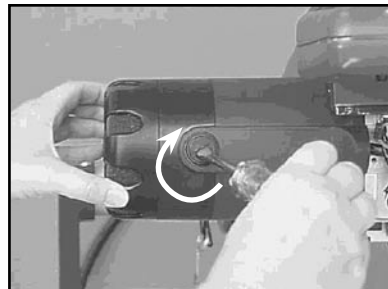

(D)
Install the Motor Brush Cap

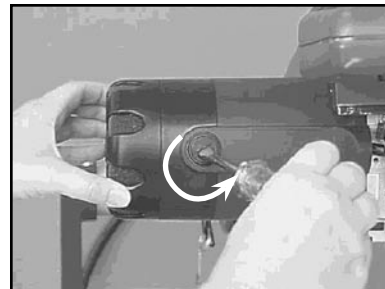

(E)
Change the second Motor Brush by repeating steps (A) to (D)

MAINTENANCE AND TROUBLESHOOTING

TROUBLESHOOTING

⚠ WARNING Verify the Lockable Switch is unlocked and the saw is disconnected from the power source before performing any troubleshooting procedure.

MOTOR STOPS TURNING

If the PX-3 Motor should stop turning, perform the following troubleshooting steps:

1. Verify all power cords and plugs are fully connected.
2. Verify the circuit breaker is 20 AMP or greater.
3. Verify the circuit breaker is not tripped. Reset if necessary.
4. Verify the source voltage is 115 volts.
5. If the Motor is still not turning after performing these troubleshooting steps, return your PX-3 to MK Diamond for repair.

BLADE WILL NOT CUT PROPERLY

If the PX-3 Blade does not cut properly, perform the following troubleshooting steps:

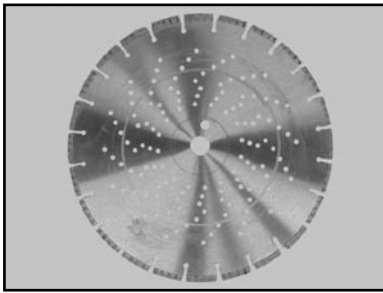

(A)
Check for Smoothness or "Glazing" (Dress blade if needed)

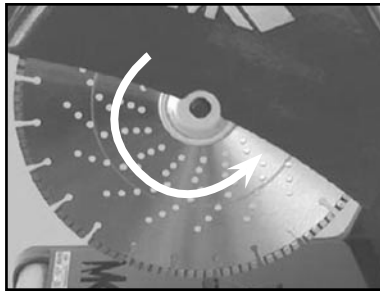

(B)
Check for proper rotation

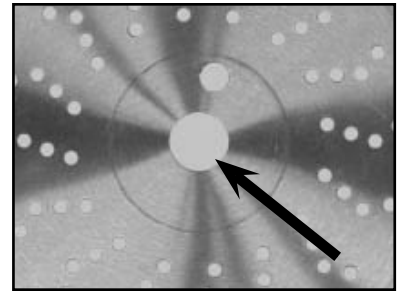

(C)
Ensure the Blade Core is not bent and Arbor is not out of round

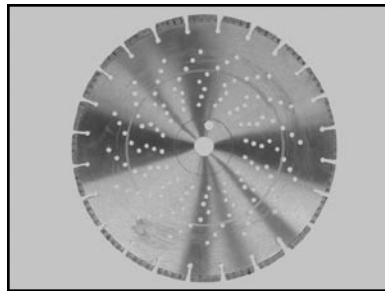

(D)
Verify the blade is correct for the material being used. (use only the PX-3 Diamond Blades)



(E)
If the Blade is still not cutting properly, contact MK at (800) 262-1575

PX-3 PARTS LIST

PARTS LIST:

Item	Description	Qty	MK p/n
A	Assembly, Frame	1	n/a
A1	Casting, Frame, Right (comp)	1	160246
A2	Casting, Frame, Left (comp)	1	160248
A3	Support, Horizontal Frame	2	160249
A4	Tube Connector, ¼-20	4	157930
A5	Screw, ¼-20 x 2" Hex Head Cap	4	158282
A6	Washer, ¼ SAE Flat	4	151915
A7	Washer, ¼ Split Lock	4	152591
A8	Drive Stud, Round Head Grooved #16 (¼) x ½	2	158071
A9	Bumper w/ Washer, 1.0 (foot)	4	160418
A10	Screw, #8-32 x 1 Pan Head Phillips	4	160446
A11	Washer, #8 Split Lock	4	160447
A12	Nut, Hex #8-32	4	153549
A13	Label, Adhesive "PX3"	1	160419
A14	Label, Prop 65 Warning	1	158322
A15	Label, Extension Cord Warning	1	155672
B	Assembly, Cutting Head	1	n/a
B1	Assembly, Arm w/ Motor & Handle	1	160251
B2	Wrench, Blade Nut, 14mm	1	158406
B2A	Wrench, Blade Shaft	1	158110
B3	Flange, Outer Blade (stamped)	1	158105
B4	Flange, Inner Blade (turned)	1	158106
B5	Screw, M10-1.5 x 20mm Hex Flange (blade retaining)	1	158107
B6	Cap, Motor	1	157877
B7	Cap, Motor Filter	1	157878
B8	Spacer Pin, Cap Screw	2	157879
B9	Element, Filter	1	157729
B10	Screw #8 x 1 ½, Combo Head Pan, Self Tapping	2	158157
B11	Label, Safety Caution	1	155576
C	Assembly, Blade Guard	1	n/a
C1	Casting, Blade Guard (comp)	1	160258
C2	Screw, M6-1 x 20mm Hex Head Cap	4	158158
C3	Washer, M6 Split Lock	4	158159
C4	Decal, Adhesive "Paver Xtreme"	1	160420
C5	Tag, Serial	1	158096
D	Assembly, Pivot Clamp	1	n/a
D1	Casting, Pivot Clamp (comp)	1	160358
D2	Screw, ¼-20 x 1 ½ Socket Hd. Cap	2	154683
D3	Pin, Pivot .625 x 5.6	1	157645
D4	Screw, Set ¼-20 x ¼ Cup Point	1	157528
D5	Spring, Torsion	1	160252
D6	Stop Block	1	158226
D7	Screw, ¼-20 x ¾, Socket Head Cap	1	152587
D8	Pin, Grooved Dowel 5/16 x 1 ¼	1	160458
D9	Lock, Cutting Head	1	160460

PX-3 PARTS LIST (cont...)

E	Assembly, Table	1	n/a
E1	Table (comp) w/ Plastic Over Mold	1	160409
E2	Screw, 5/16-18 x ¾ Hex Head Cap	4	151369
E3	Washer, 5/16 SAE Flat	4	151754
E4	Washer, 5/16 Split Lock	4	151747
E5	Backstop, Table	1	160349
E6	Screw, 3/8 x ½ Socket Head Shoulder, 5/16-18 x 1.0	1	160459
E7	Nut, Wing Nylok 5/16-18	1	151746
E8	Washer, 3/8 SAE Flat	2	150923
E9	Washer, 5/16 SAE Flat	1	151754
E10	Knob, 3 Prong 3/8-16 x 1	1	156175
E11	Washer, 3/8 Split Lock	1	150925
F	Assembly, Packaging Carton	1	n/a
F1	Carton, MK-PX3	1	160421
F2	Insert, Carton		
G	Assembly, Accessory Pack	1	n/a
G1	Blade, 14" PX10, Segmented w/ Cooling Holes (6mm rim height)	1	160448
G2	Warranty Card	1	155037
G3	Sell Sheet, Tile Accessory	1	156915
G4	Extra Filter Element	1	157729
G5	Owners Manual, MK-PX3	1	160445
J	Assembly, PX3 Dust Collector	1	n/a
J1	Nozzle, PX3 2 ½" Dust	1	160408
J2	Screw, 1/4-20 x 1 Shoulder Thumb	1	160461
J3	Nut, ¼-20 Hex w/ Washer	1	153941

THEORY

THEORY OF DIAMOND BLADES

Diamond blades do not really cut; they grind the material through friction. Diamond crystals, often visible at the leading edge and sides of the rim/segment, remove material by scratching out particles of hard, dense materials, or by knocking out larger particles of loosely bonded abrasive material.

This process eventually cracks or fractures the diamond particle, breaking it down into smaller pieces. As a result, a diamond blade for cutting soft, abrasive material must have a hard metal matrix composition to resist this erosion long enough for the exposed diamonds to be properly utilized.

Conversely, a blade for cutting a hard, non-abrasive material must have a soft bond to ensure that it will erode and expose the diamonds embedded in the matrix. These simple principles are the foundation of "controlled bond erosion".





Types of Cutting

There are two basic types of cutting-Dry or Wet; however, the PX-3 is designed only for Dry Cutting. The choice of which type of blade to use depends on:

- The requirements of the job
- The machine/tool utilizing the diamond blade
- The preference of the operator

In the case of DRY cutting, the overwhelming popularity and quantity of hand-held saws and the flexible nature of MK Diamond blades to professionally handle most ceramic, masonry, stone and concrete materials, make the DRY cutting blade a very attractive tool. When using a DRY blade, the user must be aware of distinct operating practices to ensure optimum performance. DRY cutting blades require sufficient airflow about the blade to prevent overheating of the steel core. This is best accomplished by shallow, intermittent cuts of the material with periods of "free-spinning" (for several seconds) between each cut, to maximize the cooling process.

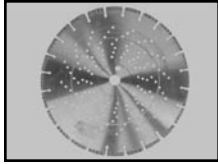
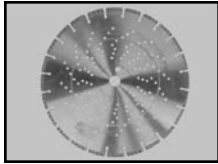
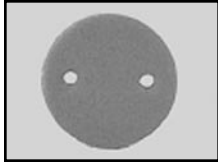
ACCESSORIES

ITEM	NUMBER	DESCRIPTION	
1.	157957	MK-PX10, Dry Cutting 14" Segmented Blade	
2.	157944	MK-PX30, Dry Cutting 14" Segmented Block Blade	
3.	157729	Motor Air Filter	
4.	160408	PX3 2-1/2" Dust Nozzle	

ORDERING & RETURN INSTRUCTIONS

ORDERING INFORMATION

You may order MK Diamond products through your local MK Diamond distributor.

When ordering direct from your Local Distributor, please have the following information ready before calling:

- The Model Number of the saw
- The Serial Number of the saw
- Where the saw was purchased and when
- The Part Number for the part(s) being ordered
- The Part Description for the part(s) being ordered

For ordering replacement parts you may order by calling toll free to – 800 421-5830 or 310 539-5221 and asking for Customer Service. For technical questions, call – 800 474-5594.

RETURN MATERIALS POLICY

To expedite the service relative to the return of a product purchased through MK Diamond, please observe the following:

NOTE: When returning any product manufactured by MK Diamond, it must have been purchased within the previous twelve (12) months.

- Have the Model Number of the saw
- Have the Serial Number of the saw
- Have the location of where the saw was purchased
- Have the date when the saw was purchased
- Contact Customer Service for approval to return the item(s)
- Obtain a Returned Goods Number (RGA) authorizing the return
- Follow the packaging instructions in the following section
- Ensure your item(s) are prepaid to the destination

For returned items, call toll free to – 800 421-5830 or 310 539-5221 and ask for Customer Service. For technical questions, call – 800 474-5594 or 310 257-2845.

PACKAGING INSTRUCTIONS

- Clean the saw before shipping
- When packing, include the following: PX-3, Diamond Blade, Blade guard and Support Angle Assembly and Adjustable Cutting Guide (Other Accessories are not required)
- Package the unit in its original container or one of comparable size (do not ship the unit partially exposed)
- Ensure all parts are secured in the packaging to prevent moving

Credit, repair or replacement of any product returned to MK Diamond is in accordance with our Standard Warranty Terms and Conditions.

AUTHORIZED SERVICE CENTERS

For quicker repair time, you may contact MK Diamond Customer Service, toll free, at 800 421-5830 or 310 539-5221 for the Authorized Service Center closest to you or visit our web site at www.mkdiamond.com.

For technical questions, call – 800 474-5594.