

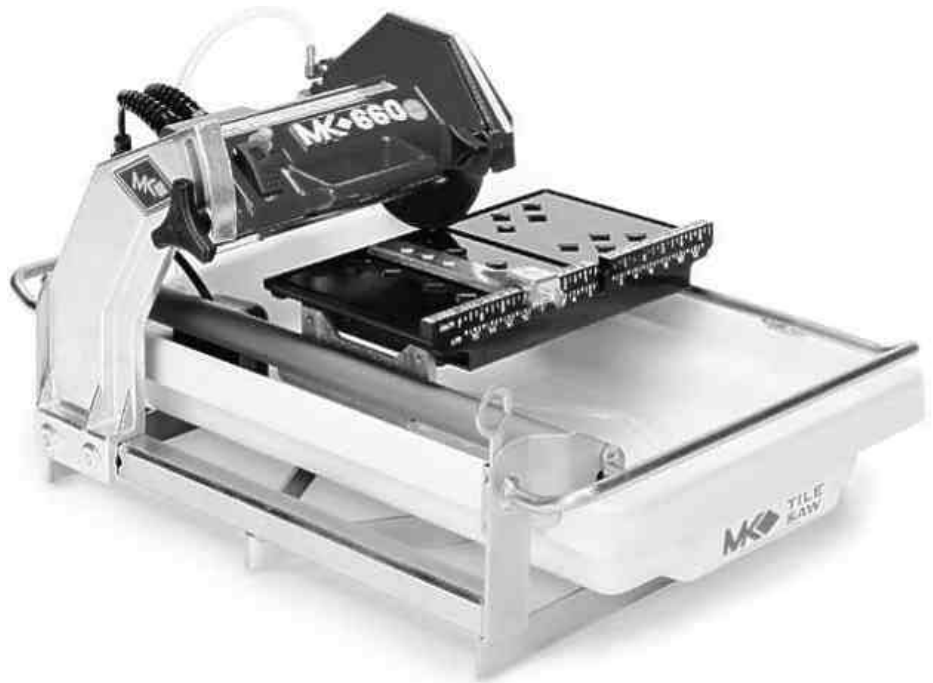

MK-660 SERIES

**TILE SAW
OWNER'S MANUAL &
OPERATING INSTRUCTIONS**



CAUTION:
Read all safety and
operating instructions
before using this
equipment

Enter the Serial Number of your new saw in the
space below. The Serial Number is located on the
rear of the Cutting Head.

SERIAL NUMBER:

NOTE:

For your (1) one year warranty to be effective,
complete the warranty card (including the Serial
Number and mail it in as soon as possible.

INTRODUCTION

We at MK Diamond want to congratulate you on selecting the MK-660 Tile Saw. We are certain that you will be pleased with your purchase. MK Diamond takes pride in producing the finest products in the industry.

Operated correctly, your MK-660 should provide you with years of quality service. In order to help you, we have included this manual. This owners manual contains information necessary to operate and maintain your MK-660 safely and correctly. Please take a few minutes to familiarize yourself with the MK-660 by reading and reviewing this manual.

If you should have questions concerning your MK-660, please feel free to call our friendly customer service department at: 800 421-5830

Regards,

MK Diamond

TABLE OF CONTENTS

	Page
SAFETY:	
Safety Messages	4
Damage Prevention Message	4
General Safety Precautions and Hazard Symbols	4
California Proposition 65 Message	6
Electrical Requirements and Grounding Instructions	7
Safety Label Locations	9
Tile Saw Specific Warnings	9
Product Specifications	10
UNPACKING, TRANSPORT, UNIVERSAL STAND, and ASSEMBLY	
Unpacking	11
Contents	11
Transport	12
Universal Stand	12
Assembly	13
SETUP, ADJUSTMENT AND OPERATION	
Setup	16
Adjustment and Operation	19
Cleanup	23
MAINTENANCE AND TROUBLESHOOTING	
Maintenance	25
Troubleshooting	30
EXPLODED VIEW AND PARTS LIST	
Exploded View	34
Parts List	35
THEORY	
Theory of Diamond Saws	37
ACCESSORIES	
Accessories	38
ORDERING and RETURN INSTRUCTIONS	
Ordering Information	39
Return Material Policy	39
Packaging Instructions	39
Authorized Service Centers	39

SAFETY

Read and follow all safety, operating and maintenance instructions. Failure to read and follow these instructions could result in injury or death to you or others. Failure to read and follow these instructions could also result in damage and/or reduced equipment life.

SAFETY MESSAGES:

Safety messages inform the user about potential hazards that could lead to injury, death and/or equipment damage. Each safety message will be preceded by one of the following (3) three words that identify the severity of the message.

⚠ DANGER

Not following instructions **WILL** lead to **DEATH** or **SERIOUS INJURY**

⚠ WARNING

Not following instructions **COULD** lead to **DEATH** or **SERIOUS INJURY**

⚠ CAUTION

Not following instructions **CAN** lead to injury

DAMAGE PREVENTION AND INFORMATION MESSAGES:

A Damage Prevention Message is to inform the user of important information and/or instructions that could lead to equipment or other property damage if not followed. Information Messages convey information that pertains to the equipment being used. Each message will be preceded by the word NOTE, as in the example below.

NOTE:

Equipment and/or property damage may result if these instructions are not followed.

GENERAL SAFETY PRECAUTIONS AND HAZARD SYMBOLS:

In order to prevent injury, the following safety precautions and symbols should be followed at all times!

Safety Precautions:

KEEP GUARDS IN PLACE.



In order to prevent injury, keep guards in place and in working order at all times.

REMOVE ADJUSTING KEYS AND WRENCHES.

Form a habit of checking to see that keys and adjusting wrenches are removed from the power tool before it is turned on.

KEEP WORK AREA CLEAN.

Cluttered work areas and benches invite accidents.

DO NOT USE IN DANGEROUS ENVIRONMENTS.

Do not use power tools in damp or wet locations nor expose them to rain. Always keep the work area well lighted.

KEEP CHILDREN AWAY.

All visitors and children should be kept a safe distance from work area.

MAKE THE WORKSHOP KID PROOF.

Make the workshops kid proof by using padlocks, master switches or by removing starter keys.

DO NOT FORCE THE TOOL.

A power tool will do a job better and safer operating at the rate for which it was designed.

USE THE RIGHT TOOL.

Do not force a tool or an attachment, to do a job that it was not designed to do.

SAFETY

USE THE PROPER EXTENSION CORD.

If using an extension cord make sure it is in good condition first. When using an extension cord, be sure to use one heavy enough to carry the current your product will draw. An undersized cord will cause a drop in line voltage that will result in a loss of power and overheating. TABLE 1, Page 8 shows the correct AWG size to use depending on cord length and nameplate ampere rating. If in doubt, use the next heavier gage. The smaller the gage number, the heavier the cord.

WEAR PROPER APPAREL.

Do not wear loose clothing, gloves, neckties, rings, bracelets, or other jewelry that may be caught in moving parts. Non-slip footwear is recommended. Wear protective hair covering to contain long hair.

ALWAYS USE SAFETY GLASSES.



Safety glasses should always be worn when working around power tools. In addition, a face, dust mask or respirator should be worn if a cutting operation is dusty. Everyday eyeglasses only have impact resistant lenses and may not prevent eye injury-they are NOT safety glasses.

SECURE WORK.

Clamps or a vise should be used to hold work whenever practical. Keeping your hands free to operate a power tool is safer.

DO NOT OVERREACH.

Keep proper footing and balance at all times by not overreaching.

MAINTAIN TOOLS WITH CARE.

Keep tools clean for the best and safest performance. Always follow maintenance instructions for lubricating, and when changing accessories.

DISCONNECT TOOLS.

Power tools should always be disconnected before servicing or when changing accessories, such as blades, bits, cutters, and the like.

REDUCE THE RISK OF UNINTENTIONAL STARTING.



Make sure the ON/OFF Switch is in the OFF position before plugging in a power tool.

USE RECOMMENDED ACCESSORIES.

Consult the owner's manual for recommended accessories. Using improper accessories may increase the risk of personal or by-stander injury.

NEVER STAND ON THE TOOL.

Serious injury could occur if a power tool is tipped, or if a cutting tool is unintentionally contacted.

CHECK FOR DAMAGED PARTS.

Before using a power tool, check for damaged parts. A guard or any other part that is damaged should be carefully checked to determine it would operate properly and perform its intended function. Always check moving parts for proper alignment or binding. Check for broken parts and mountings and all other conditions that may affect the operation of the power tool. A guard, or any damaged part, should be properly repaired or replaced.

DIRECTION OF FEED.

Always feed work into a blade or cutter against the direction of rotation. A blade or cutter should always be installed such that rotation is in the direction of the arrow imprinted on the side of the blade or cutter.

NEVER LEAVE A TOOL RUNNING UNATTENDED – TURN POWER OFF.

Do not leave a tool until it comes to a complete stop. Always turn a power tool OFF when leaving the work area, or, when a cut is finished.

SAFETY

Hazard Symbols:

ELECTRICAL SHOCK!



Never touch electrical wires or components while the motor is running. Exposed, frayed or worn electrical motor wiring can be sources of electrical shock that could cause severe injury or burns.

ACCIDENTAL STARTS!



Before plugging the equipment into an electrical outlet, be sure the ON/OFF Switch is in the OFF position to prevent accidental starting. Unplug the power tool before performing any service operation.

ROTATING OR MOVING PARTS!



Keep hands, feet, hair, and clothing away from all moving parts to prevent injury. Never operate a power tool with covers, shrouds, or guards removed.

⚠WARNING

Sawing and drilling generates dust. Excessive airborne particles may cause irritation to eyes, skin and respiratory tract. To avoid breathing impairment, always employ dust controls and protection suitable to the material being sawed or drilled; See OSHA (29 CFR Part 1910.1200). Diamond Blades improperly used are dangerous. Comply with American National Standards Institute Safety Code, B7.1 and, Occupational Safety and Health Act covering Speed, Safety Guards, Flanges, Mounting Procedures, General Operating Rules, Handling, Storage and General Machine Conditions.

CALIFORNIA PROPOSITION 65 MESSAGE:

⚠WARNING

Some dust created by power sanding, sawing, grinding, drilling, and other construction activities contain chemicals known [to the State of California] to cause cancer, birth defects or other reproductive harm. Some examples of these chemicals are:

- Lead, from lead-based paints
- Crystalline silica, from bricks and cement and other masonry products and
- Arsenic and chromium, from chemically treated lumber

For further information, consult the following sources:

<http://www.osha-slc.gov/sltc/silicacrystalline/index.html>

http://www.oehha.org/prop65/out_of_date/6022kLstA.html

Your risk from these exposures varies depending on how often you do this type of work. To reduce your exposure to these chemicals, work in a well-ventilated area, and work with approved safety equipment, such as those dust masks that are specially designed to filter out microscopic particles.

SAFETY

ELECTRICAL REQUIREMENTS AND GROUNDING INSTRUCTIONS:

In order to prevent potential electrical shock and injury, the following electrical safety precautions and symbols should be followed at all times!

⚠ WARNING



In case of a malfunction or breakdown, grounding provides a path of least resistance for electric current to reduce the risk of electric shock. This tool is equipped with an electric cord having an equipment-grounding conductor and a grounding plug. The plug must be plugged into a matching outlet that is properly installed and grounded in accordance with all local codes and ordinances.

- Do not modify the plug provided – if it will not fit the outlet; have the proper outlet installed by a qualified electrician
- Improper connections of the equipment-grounding conductor can result in a risk of electric shock. The equipment-grounding conductor is the insulated conductor that has an outer surface that is green, with or without yellow stripes. If repair or replacement of the electric cord or plug is necessary, do not connect the equipment-grounding conductor to a live terminal
- Check with a qualified electrician or service personnel if the grounding instructions are not completely understood, or if in doubt as to whether the tool is properly grounded
- Use only 3-wire extension cords that have 3-prong grounding plugs and 3-pole receptacles that accept the tool's plug
- Repair or replace a damaged or worn cord immediately

⚠ WARNING



This tool is intended for use on a circuit that has an outlet that looks like the one shown in Sketch A of Figure 1. The tool has a grounding plug that looks like the plug illustrated in Sketch A of FIGURE 1. A temporary adapter, which looks like the adapter illustrated in sketches B and C, may be used to

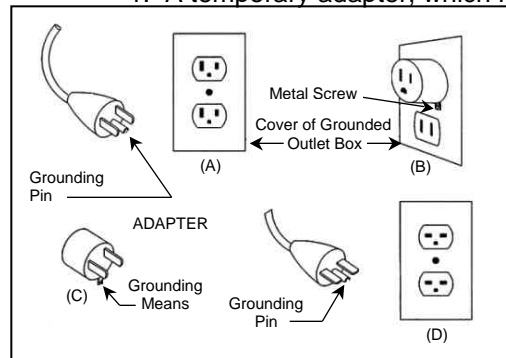

connect this plug to a 2-pole receptacle as shown in Sketch B, if a properly grounded outlet is not available. The temporary adapter should be used only until a properly grounded outlet can be installed by a qualified electrician. The green-colored rigid ear, lug, and the like, extending from the adapter, must be connected to a permanent ground such as a properly grounded outlet box.

NOTE: Use of a temporary adapter is not permitted in Canada.

FIGURE 1

⚠ WARNING



To reduce the risk of electrocution, keep all connections dry and off the ground.

A Ground Fault Circuit Interrupter (GFCI) should be provided on the circuit(s) or outlet(s) to be used for the Saw. Receptacles are available having built-in GFCI protections and may be used for this measure of safety.

When using an extension cord, the GFCI should be installed closest to the power source, followed by the extension cord and lastly, the saw.

SAFETY



To avoid the possibility of the appliance plug or receptacle getting wet, position the saw to one side of a wall mounted receptacle. This will prevent water from dripping onto the receptacle or plug. A "drip loop," shown in FIGURE 2, should be arranged by the user to properly position the power cord relative to the power source.

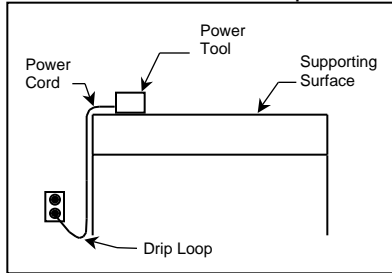

FIGURE 2

The "drip loop" is that part of the cord below the level of the receptacle, or the connector, if an extension cord is used. This method of positioning the cord prevents the travel of water along the power cord and coming in contact with the receptacle.

If the plug or receptacle gets wet, **DO NOT** unplug the cord. Disconnect the fuse or circuit breaker that supplies power to the tool. Then unplug and examine for presence of water in the receptacle.

⚠WARNING



Use only extensions cords that are intended for outdoor use. These extension cords are identified by a marking "Acceptable for use with outdoor appliances; store indoors while not in use." Use only extension cords having an electrical rating not less than the rating of the product. Do not use damaged extension cords. Examine extension cords before using and replace if damaged. Do not abuse extension cords and do not yank on any cord to disconnect. Keep cords away from heat and sharp edges. Always disconnect the extension cord from the receptacle before disconnection the product from the extension cord.

⚠WARNING

To reduce the risk of electrocution, keep all connections dry and off the ground. Do not touch the plug with wet hands.

⚠WARNING



Use of undersize extension cords result in low voltage to the motor that can result in motor burnout and premature failure. MK Diamond warns that equipment returned to us showing signs of being run in a low voltage condition, through the use of undersized extension cords will be repaired or replaced totally at the customers expense. There will be no warranty claim.

To choose the proper extension cord,

- Locate the length of extension cord needed in TABLE 1 below.
- Once the proper length is found, move down the column to obtain the correct AWG size required for that length of extension cord.

Extension Cord Minimum Gage for Length				
Volts	Total Length of Cord in Feet			
	25 ft.	50 ft.	100 ft.	150 ft.
120V	AWG	AWG	AWG	AWG
	18	16	14	12

TABLE 1

SAFETY

SAFETY LABEL LOCATIONS:

Safety labels are located according to Figures 1 and 2 below. The labels contain important safety information. Please read the information contained on each safety label. These labels are considered a permanent part of your saw. If a label comes off or becomes hard to read, contact MK Diamond or your dealer for a replacement

Item	Location	Description	Part No.
1A.	Cutting Head Front	Caution Operating Instructions	155214
1B.	Cutting Head Rear	Serial Number and Specifications	156561
1C.	Cutting Head Front	Motor Reset	154409
2A	Pump Left Side	Warning Connect to Grounded Receptacle	N/A
2B	Pump Right Side	Pump Specifications	N/A

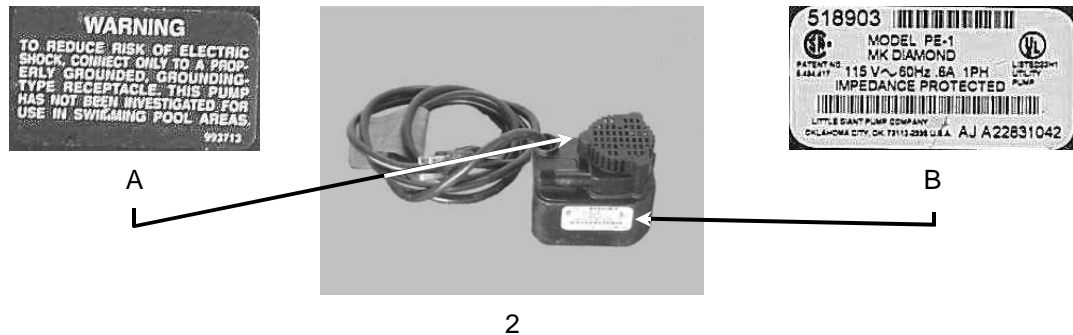
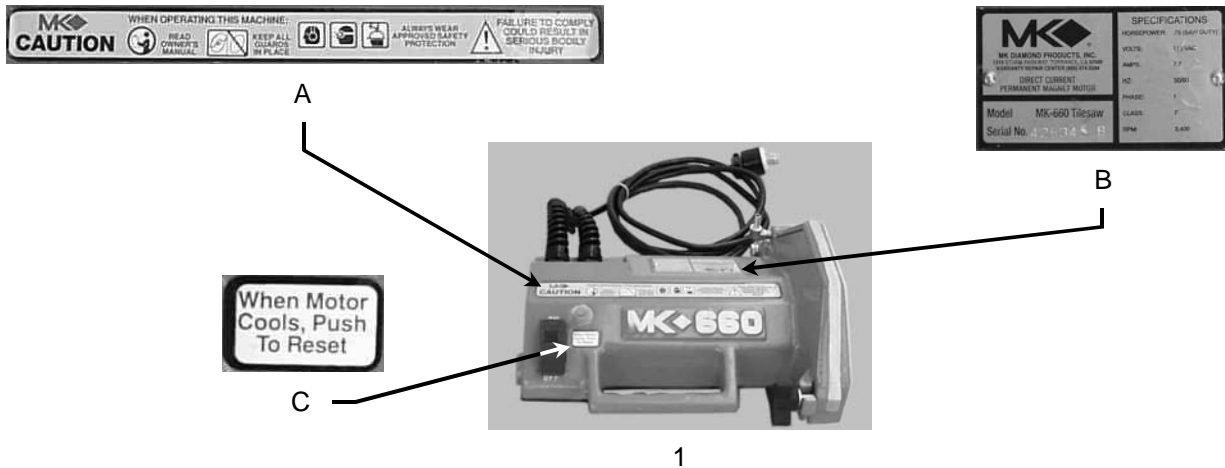

TILE SAW SPECIFIC WARNINGS:

⚠️WARNING

Wear eye protection.

Use splash hood for every operation for which it can be used.

Disconnect saw before servicing, when changing cutting blades, and cleaning.

Use tool only with smooth edge cutting blades free of openings and grooves.

Replace damaged cutting blade before operating.

SAFETY

PRODUCT SPECIFICATIONS:

The MK-660 is a versatile Tile Saw. Operated and used according to this manual, the MK-660 will provide years of dependable service.

General Description:

The MK-660 Tile Saw is engineered as a tabletop or stand mounted wet tile saw. The saw includes a powerful 115v totally enclosed direct drive DC motor with a thermal protective overload. The saw is capable of cutting tile up to fourteen (14) inches in length, or diagonally cutting tile up to ten (10) inches. The saw can cut an object one and one-half (1-1/4) inches thick in one pass.

Motor Specifications:

Motor specifications for the MK-660 are listed in Table 2 below.

Voltage	115 v
Motor Amperage	8.8 a
Frequency	60 Hz
RPM	3500 rpm
Horse Power	3/4 hp
Weight	53 lbs

Table 2

Thermal Overload Protection:

The motor is protected by a thermal overload equipped with a manual reset.

Blade Capacity:

The MK-660 uses a seven (7) inch (178 mm) diameter, wet cutting continuous rim, MK Diamond blade with a five-eighths (5/8) inch (15.875 mm) arbor.

Tile Types:

The MK-660 can cut a variety of tile types including Porcelain, Terracotta, Marble, Quarry and Slate, or almost any other non-ferrous material.

NOTE:

The MK-660 is not designed to cut plastic or ferrous (metals) material.

UNPACKING, TRANSPORT, UNIVERSAL STAND and ASSEMBLY

UNPACKING:

Your MK-660 has been shipped from the factory thoroughly inspected. Only minimal assembly is required.

⚠CAUTION Use proper lifting techniques when lifting the MK-660.

If not done, remove the MK-660, accessory box from the carton.

CONTENTS:

In your container, you will find one (1) MK-660 frame and water pan, one (1) MK-660 cutting head, (1) cutting head height adjusting knob, (1) height adjusting knob flat washer, one (1) 7-inch wet cutting continuous rim diamond blade, one (1) adjustable cutting guide, one (1) electric water pump, one (1) pump discharge fitting, one (1) cooling transfer tube, one (1) flow adjusting clamp, one (1) drain plug, one (1) blade wrench one (1) inner flange wrench, (1) splash guard, one (1) owners manual, one (1) pump manual and one (1) warranty card.



MK-660 Frame
and Water Pan



MK-660
Cutting Head



Height Adjusting
Knob



Height Adjusting
Knob Flat Washer



Diamond Blade



Adjustable
Cutting Guide



Electric
Water Pump



Pump
Discharge Fitting



Cooling
Transfer Tube



Flow
Adjusting Clamp



Drain Plug

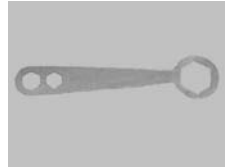

Blade Nut
Wrench



Inner Flange
Wrench



Splash
Guard



Owners
Manual



Pump
Manual

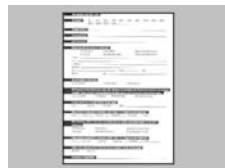

Warranty
Card

UNPACKING, TRANSPORT, UNIVERSAL STAND and ASSEMBLY

TRANSPORT:

- ⚠CAUTION 1. The MK-660 weighs approximately fifty-three (53) pounds; use care when transporting.
2. Never transport the MK-660 with water in the Water Pan.

The MK-660 is designed with a rigid frame and removable Cutting Head. Always use proper lifting techniques when lifting the MK-660.

To lift the saw, grasp the front and back of the frame at the lift points shown below.

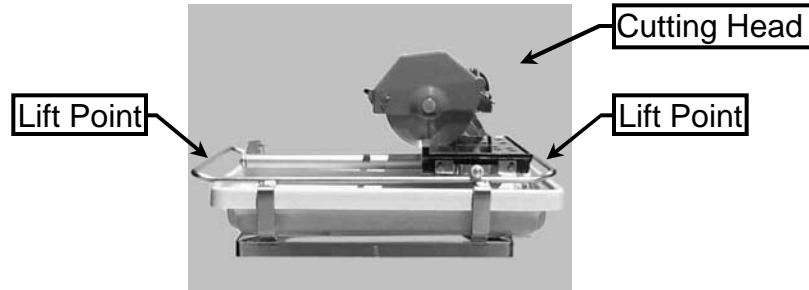

UNIVERSAL STAND:

- ⚠CAUTION The MK-660 weighs fifty-three (53) pounds; follow the guidelines for transport in the TRANSPORT section, when placing it on the stand.

Note: If using the MK Diamond, Universal Stand, follow the following steps.

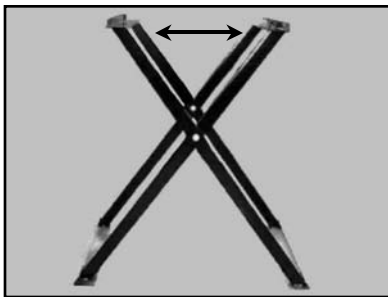

(A)
Open the Universal Stand and place on flat surface

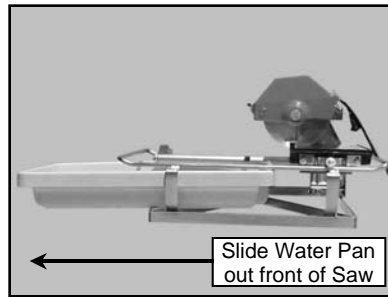

(B)
Remove Water Pan

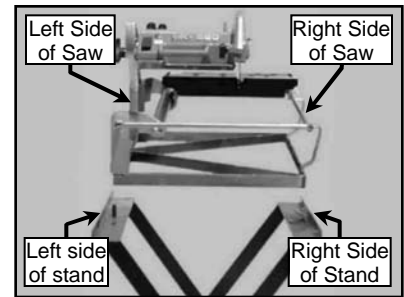

(C)
Orient the Saw to the Stand

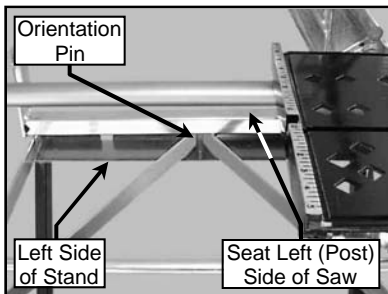

(D)
Seat Left (Post) Side of saw onto stand between stand Orientation Pin

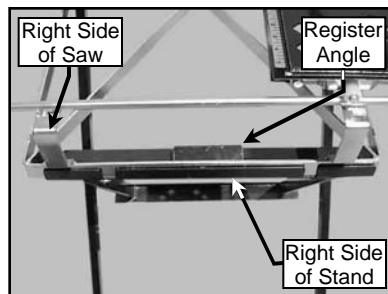

(E)
Seat Right Side of saw onto stand between stand and Register Angle

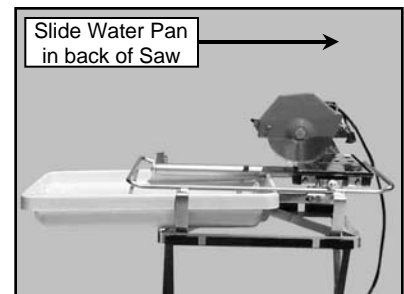

(F)
Reinstall the Water Pan

UNPACKING, TRANSPORT, UNIVERSAL STAND and ASSEMBLY

ASSEMBLY:

Follow the assembly instructions to prepare your MK-660 for operation.

1. Cutting Head Installation:

NOTE: If the Cutting Head is installed, go to step 2.

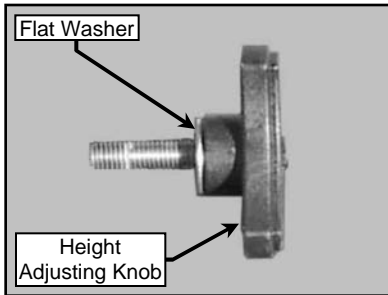

(A)
Place the Flat Washer onto the Height Adjusting Knob

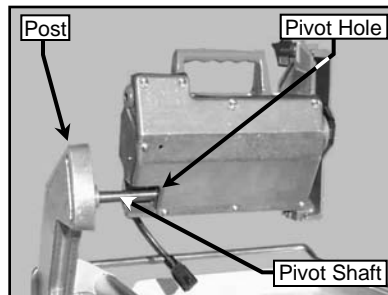

(B)
Align Cutting Head Pivot Hole to the Post, Pivot Shaft

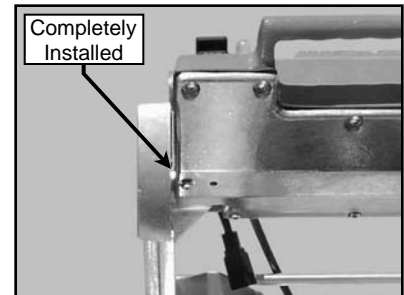

(C)
Verify the Cutting Head is completely installed and seated on the Pivot Shaft

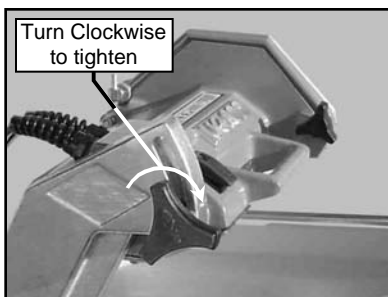

(D)
Install the Cutting Head onto the Post, Pivot Shaft and Install The Adjusting Knob

2. Diamond Blade Installation:

NOTE: When installing the Retaining Screw, do not "cross-thread" and DO NOT over tighten the screw.

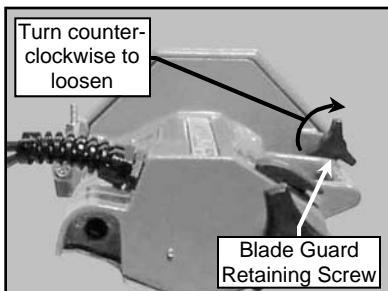

(A)
Loosen the Blade Guard Retaining Screw

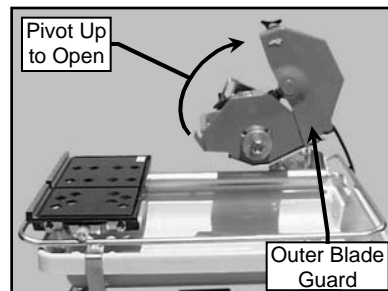

(B)
Open the Outer Blade Guard to expose the Retaining Nut and Flanges

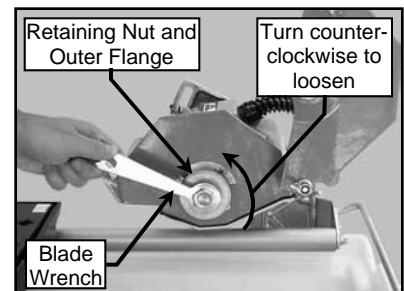

(C)
Using the Blade Nut Wrench, loosen and then remove the Retaining Nut and Outer Flange

UNPACKING, TRANSPORT, UNIVERSAL STAND and ASSEMBLY

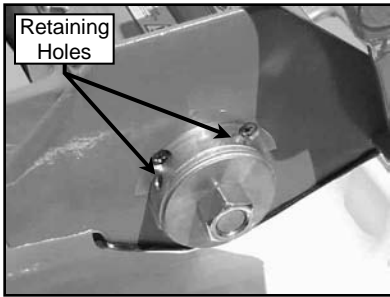

(D)
Locate the Inner Flange Wrench Retaining Holes

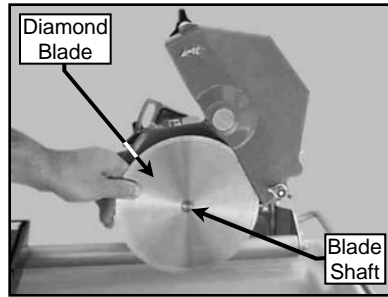

(E)
Install Diamond Blade onto Blade Shaft

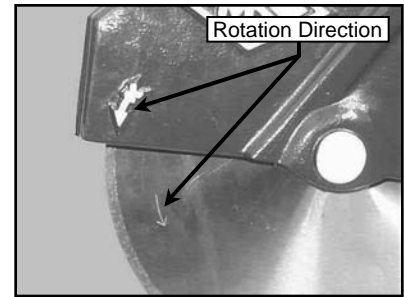

(F)
Verify the Blade is seated on the Blade Shaft and direction of rotation is correct

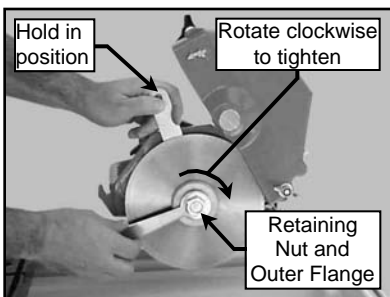

(G)
Install the Retaining Nut and Outer Flange, Hold the Shaft using the Inner Flange Retaining Wrench and tighten using the Blade Wrench

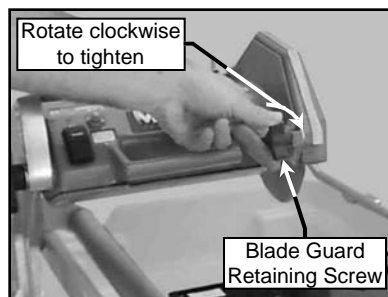

(H)
Close the Outer Blade Guard and tighten the Blade Guard Retaining Screw

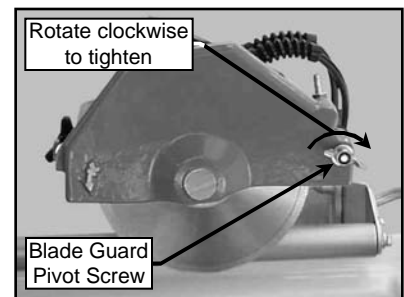

(I)
Tighten the Outer Blade Guard Pivot Screw

3. Adjustable Cutting Guide Installation:

NOTE: The Adjustable Cutting Guide can be used on either side of the Diamond Blade.

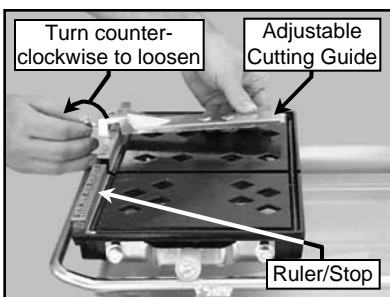

(A)
Loosen Adjustable Cutting Guide retaining thumbscrew and place it over the Movable Cutting Table Ruler/Stop

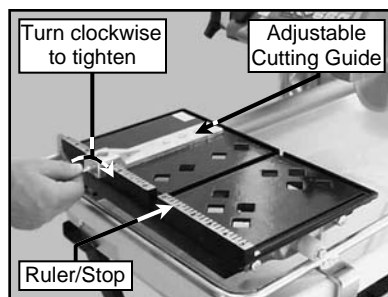

(B)
Place the Adjustable Cutting Guide onto the Movable Cutting Table Ruler/Stop and tighten the retaining thumbscrew

UNPACKING, TRANSPORT, UNIVERSAL STAND and ASSEMBLY

4. Splash Guard Installation:

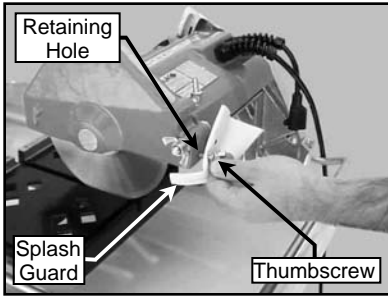

(A)

Install the retaining thumbscrew through the washer and Splash Guard, then align to the hole found on back of the Blade Guard

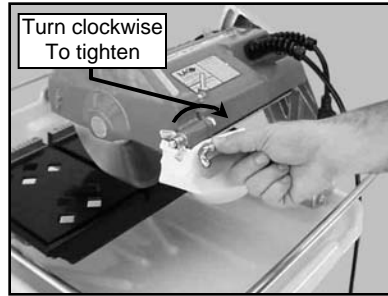

(B)

Install the Splash Guard onto the Blade Guard

5. Water Pump Preparation:

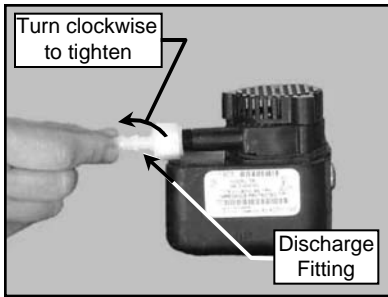

(A)

Install Water Pump Discharge Fitting

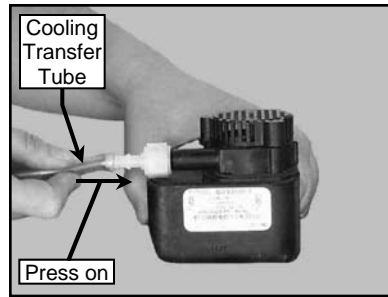

(B)

Press one end of the Cooling Transfer Tube onto the Water Pump Discharge Fitting

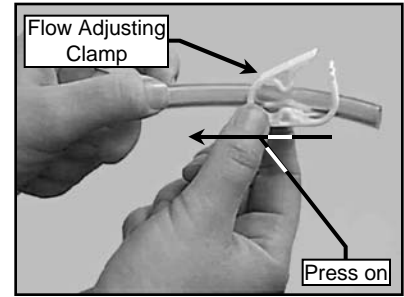

(C)

Slide Cooling Flow Adjusting Clamp onto the Cooling Transfer Tube

SETUP, ADJUSTMENT and OPERATION

SETUP:

1. Pre-start Inspection:

Prior to beginning work, a pre-start inspection of the saw should be performed.

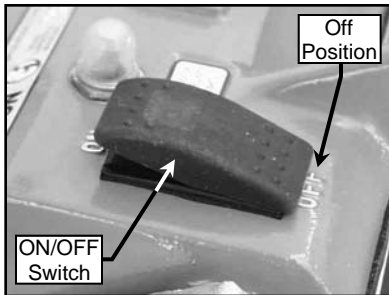

(A)
Ensure the ON/OFF Switch is in the OFF position

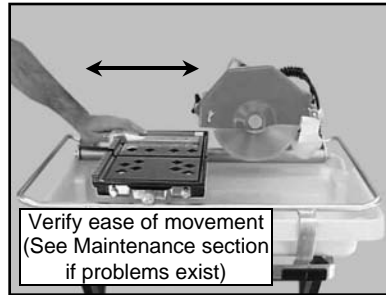

(B)
Verify the Movable Cutting Table moves freely

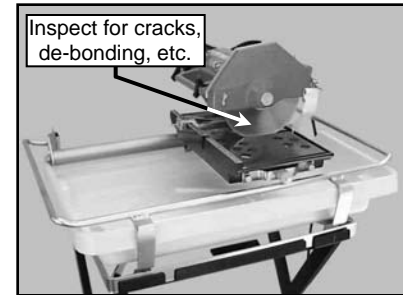

(C)
Inspect the Diamond Blade for damage – verify the blade is correct for the material being cut

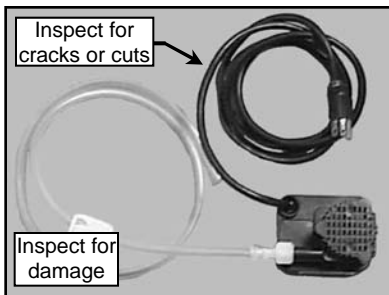

(D)
Inspect the Pump Assembly for damage – ensure the cord is free of cracks or cuts

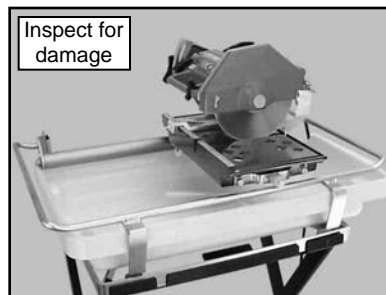

(E)
Inspect the MK-660 for damage – ensure the cord is free of cracks or cuts

2. Connecting the Water Pump:

- ⚠ WARNING** 1. To prevent the possibility electrical shock, the MK-660 **MUST** be de-energized when connecting the Water Pump.
2. To prevent the possibility of electrical shock, use only MK Diamond qualified replacement parts

NOTE: To prevent pump damage, the Water Pump must be disconnected if cutting with a Dry Blade.

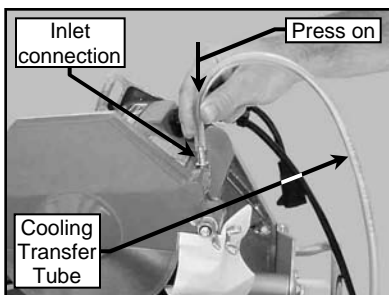

(A)
Connect the Cooling Transfer Tube to the inlet connection of the Blade Guard

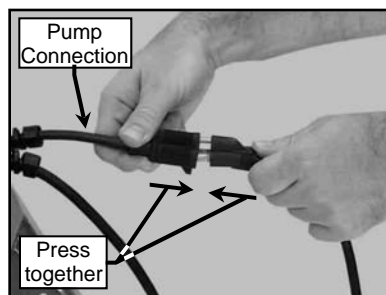

(B)
Connect the Water Pump power cord to the connection found on the back of the motor

SETUP, ADJUSTMENT and OPERATION

3. Water Pump Setup for Operation:

The Water Pump can be setup for operation in two ways, External Water Source or Re-circulation.

NOTE: If using a dry blade for operation, DO NOT connect the water pump.

I. External Water Source:

This is the preferred method of cooling.

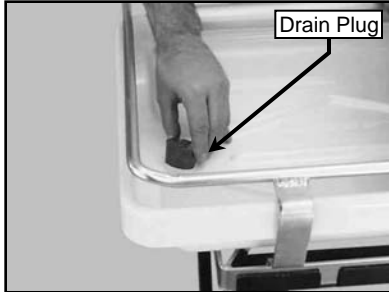

(A)
Remove the Drain plug

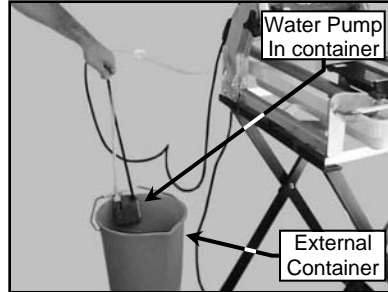

(B)
Place the Water Pump
In an external container

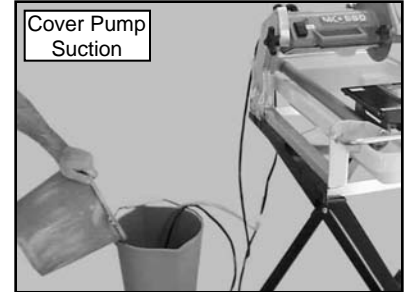

(C)
Fill the external container until
water completely covers the
Water Pump suction

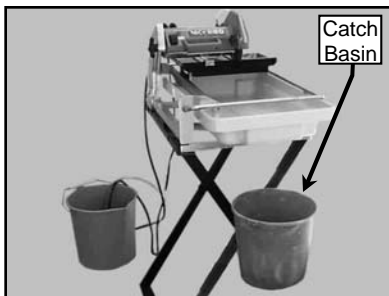

(D)
Place an external catch Basin
below the Water Pan drain hole

II. Re-circulation:

NOTE: When using the re-circulation method, the water should be changed often for longer pump life.

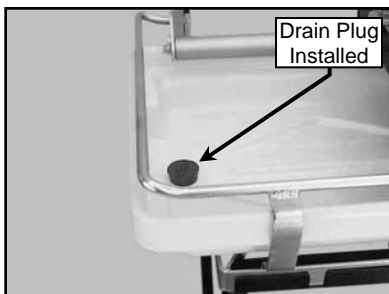

(A)
Ensure the Drain Plug is
installed in the Water Pan

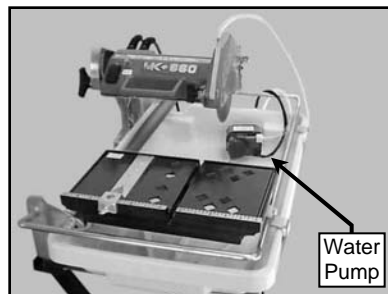

(B)
Place the Water Pump in the
back of the Water Pan

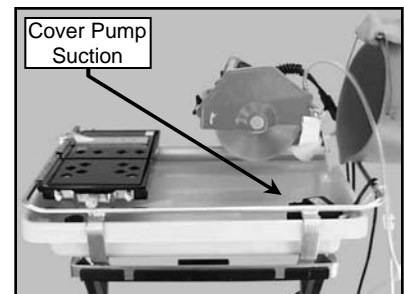

(C)
Fill the Water Pan until water
completely covers the Water
Pump suction

SETUP, ADJUSTMENT and OPERATION

4 MK-660 Setup for Operation:

- ⚠CAUTION** 1. Before powering or starting, check for damage that could prevent this equipment from proper operation or performing it's intended function. Check for binding and alignment of moving parts. Check for damaged, broken, or missing parts.
2. Verify the On/Off switch is in the OFF position.
3. Before connecting the MK-660 to a power supply, be sure the voltage, cycle and phase of the job site power source meet the requirements of TABLE 3

VOLTAGE:	115v
CYCLE:	60hz
PHASE:	1-phase

TABLE 3

4. If using an extension power cord, make sure the length and wire gauge correspond to the requirements listed in TABLE 1 on page 8. An extension power cord that is too small in wire gauge (diameter), or too long in length, will cause the motor to overheat and could cause premature failure.
5. Use an approved Ground Fault Circuit Interrupter (GFCI)
6. Do not cover the motor vents as this could lead to motor overheating.

NOTE: In order to avoid breaker tripping, a 20-amp circuit breaker should be used.

Portable Generator:

If using a portable generator to provide power, ensure the generator meets the following minimum requirements:

8 KW

120/240 volts

66.7/33.3 amps

Single Phase

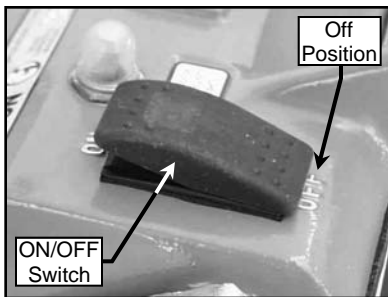

(A)

Ensure the ON/OFF Switch is in the OFF position

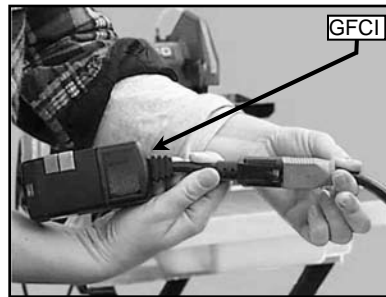

(B)

Plug MK-660 into the GFCI

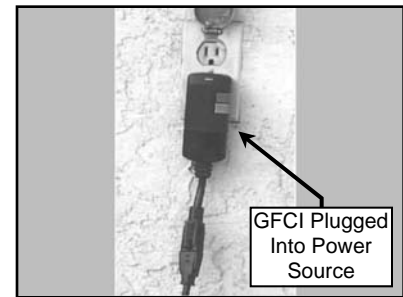

(C)

Plug the GFCI into the Power source

SETUP, ADJUSTMENT and OPERATION

ADJUSTMENT and OPERATION:

1. Cutting Straight Edges:

⚠CAUTION DO NOT FORCE THE TOOL. It will do the job better and safer at the rate for which it was designed.

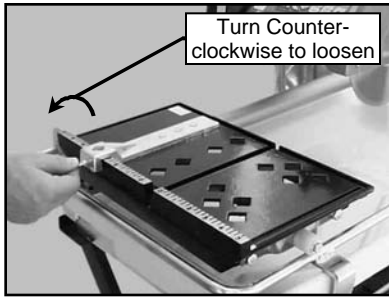

(A)
Loosen the Adjustable Cutting Guide retaining thumbscrew

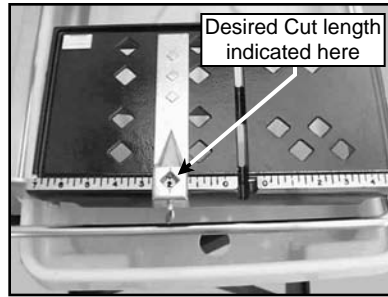

(B)
Position the Adjustable Cutting Guide to desired cut length indicated inside the diamond

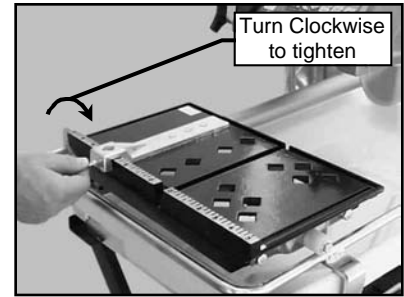

(C)
Tighten the retaining thumbscrew

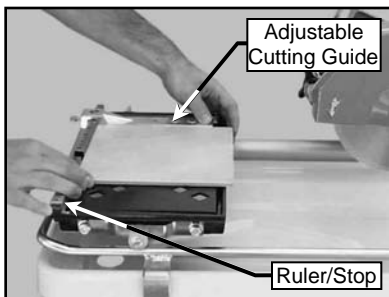

(D)
Place the tile against the Ruler/Stop and Cutting Guide

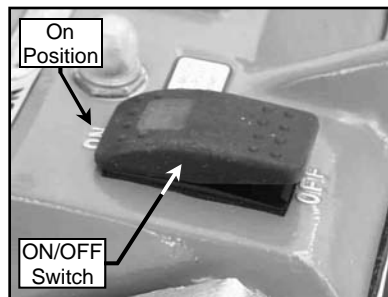

(E)
Turn the motor ON

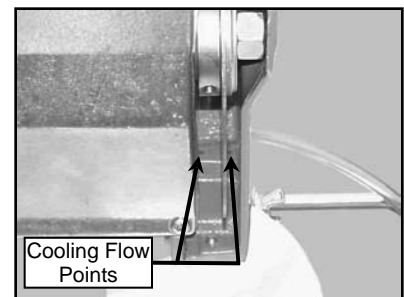

(F)
Verify cooling flow on both sides of the blade (See Maintenance Section to adjust flow)

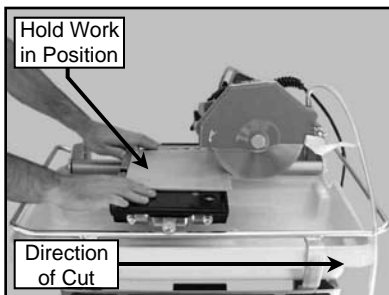

(G)
Perform the cut

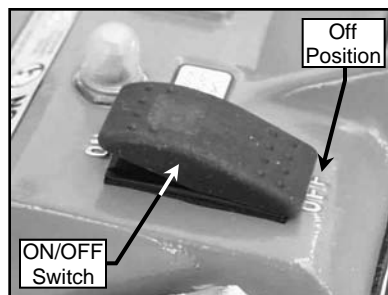

(H)
Turn the motor OFF when work is complete

SETUP, ADJUSTMENT and OPERATION

2. Diagonal Cutting:

NOTE: To cut diagonal, the Dual 45° Flat Angle Guide (MK Diamond Part No. 134557-MK) should be used.

⚠CAUTIONDO NOT FORCE THE TOOL. It will do the job better and safer at the rate for which it was designed.

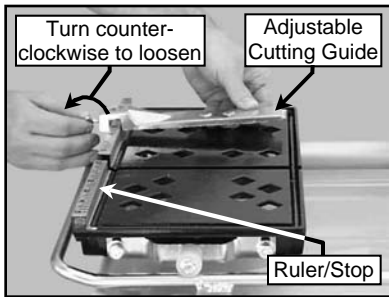

(A)
Remove the Adjustable Cutting Guide

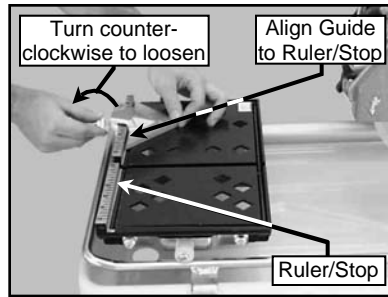

(B)
Place the Dual 45° Flat Angle Guide on the Ruler/Stop

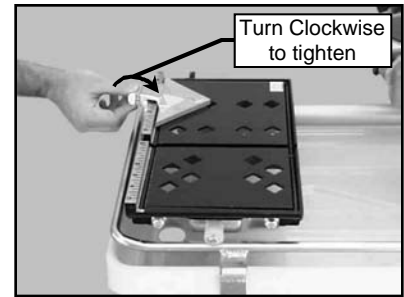

(C)
Position the Dual 45° Flat Angle Guide and tighten the retaining thumbscrew

NOTE: If Cutting the tile in two equal halves, align the tile in the V-notch of the Movable Cutting Table Ruler/Stop.

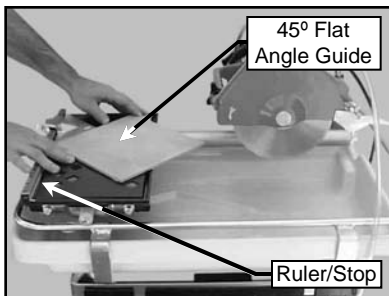

(D)
Position the tile against the Dual 45° Flat Angle Guide and the Ruler/Stop

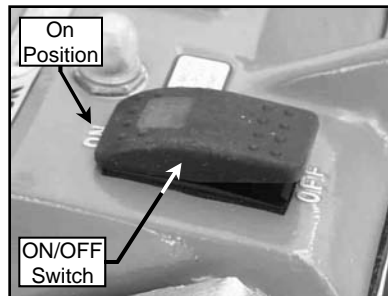

(E)
Turn the motor ON

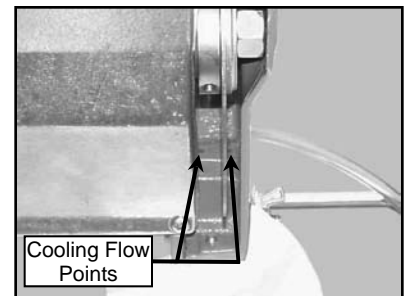

(F)
Verify cooling flow on both sides of the blade (See Maintenance Section to adjust flow)

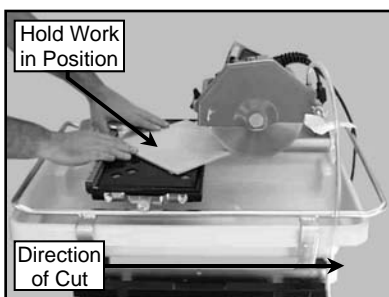

(G)
Perform the cut

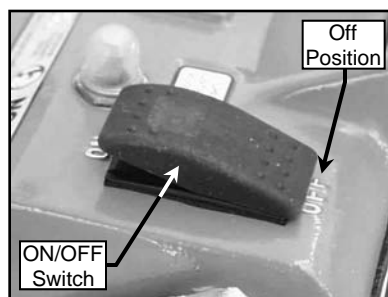

(H)
Turn the motor OFF when work is complete

SETUP, ADJUSTMENT and OPERATION

3. 45° Miter Cutting:

NOTE: To cut 45° Miters, the 45° Bullnose Miter Guide (MK Diamond Part No. 134585-MK) should be used.

⚠CAUTIONDO NOT FORCE THE TOOL. It will do the job better and safer at the rate for which it was designed.

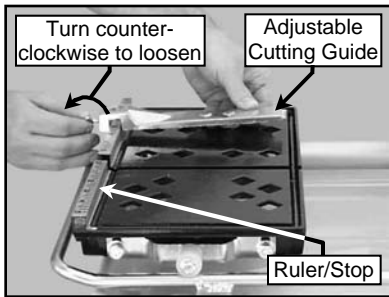

(A)
Remove the Adjustable Cutting Guide

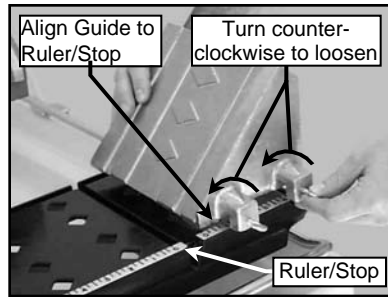

(B)
Place the 45° Bullnose Miter Guide on the Ruler/Stop

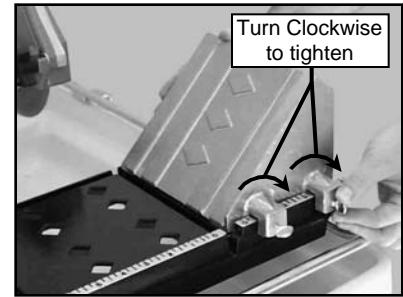

(C)
Position the 45° Bullnose Miter Guide and tighten the retaining thumbscrew

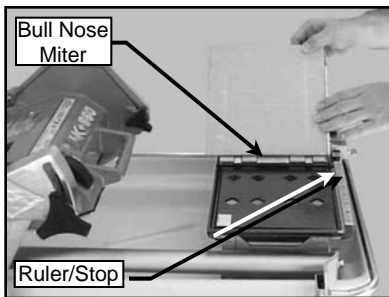

(D)
Position the tile on the 45° Bullnose Miter Guide and the Ruler/Stop

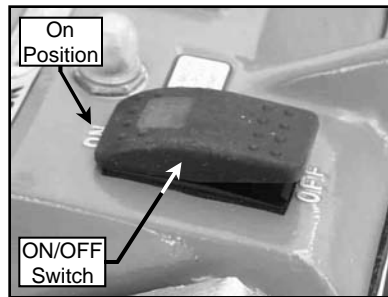

(E)
Turn the motor ON

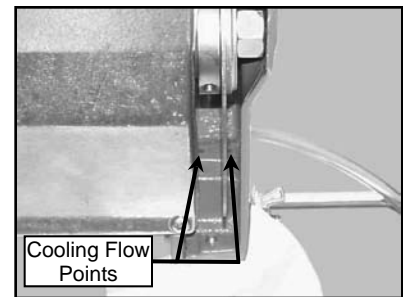

(F)
Verify cooling flow on both sides of the blade (See Maintenance Section to adjust flow)

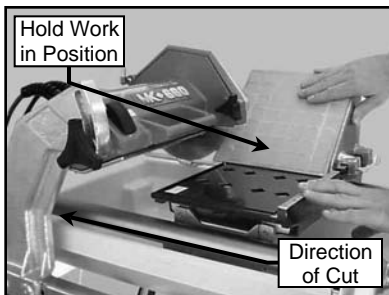

(G)
Perform the cut

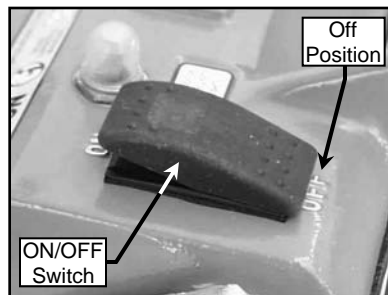

(H)
Turn the motor OFF when work is complete

SETUP, ADJUSTMENT and OPERATION

4. Off-angle Cutting:

NOTE: To cut angles other than 45° angles, a Protractor (MK Diamond Part No. 134569-MK) should be used.

⚠CAUTIONDO NOT FORCE THE TOOL. It will do the job better and safer at the rate for which it was designed.

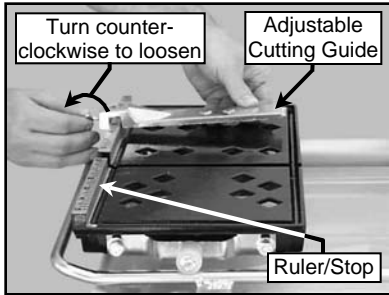

(A)
Remove the Adjustable Cutting Guide

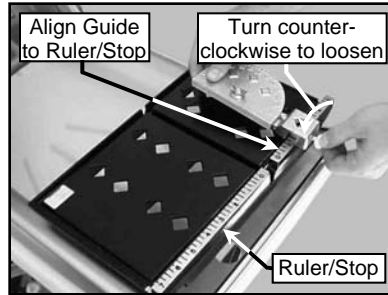

(B)
Place the Protractor on the Ruler/Stop

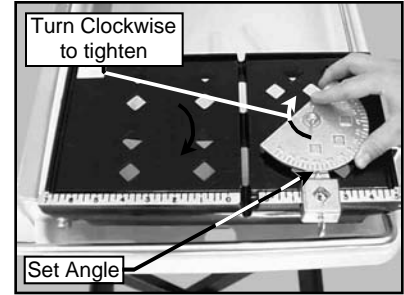

(C)
Set the desired angle and tighten the thumbscrew

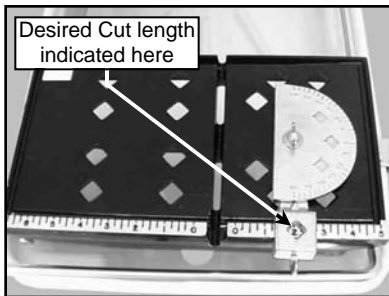

(D)
Position the Protractor Cutting Guide to the desired cut length indicated inside the diamond

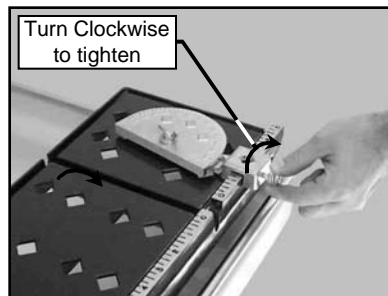

(E)
Tighten the retaining thumbscrew

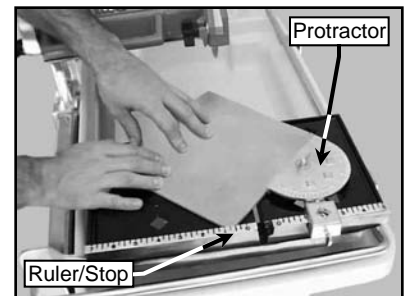

(F)
Position the tile against the Protractor and the Ruler/Stop

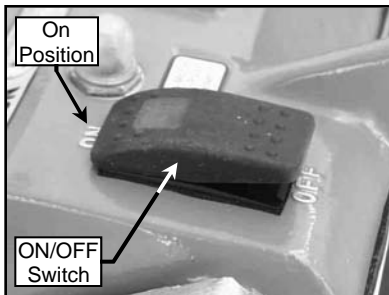

(G)
Turn the motor ON

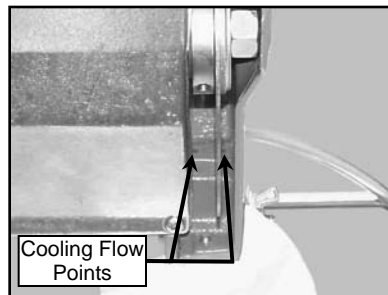

(H)
Verify cooling flow on both sides of the blade (See Maintenance Section to adjust flow)

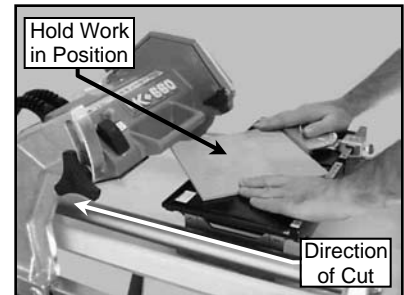

(I)
Perform the cut

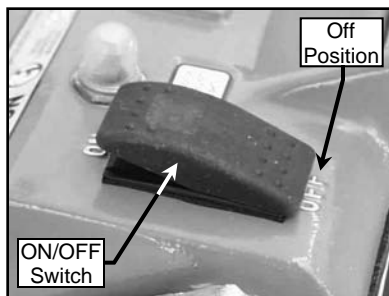

(J)
Turn the motor OFF when work is complete

SETUP, ADJUSTMENT and OPERATION

5. Cleanup:

- NOTES: 1. If an external water source was used, steps A through C may be skipped.
2. Dispose of wastewater in accordance with applicable Federal, State and Local laws.

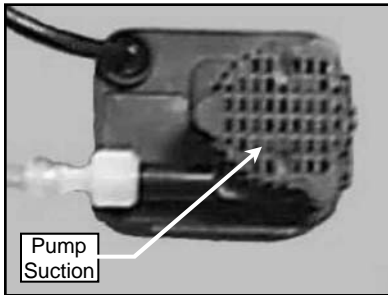

(A)
Clean the Water Pump suction
of all debris

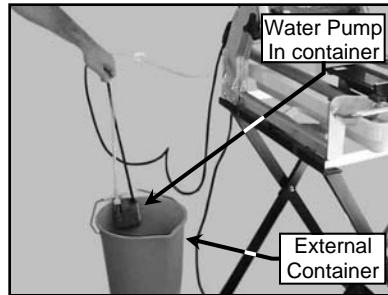

(B)
Place the Water Pump in an
external container

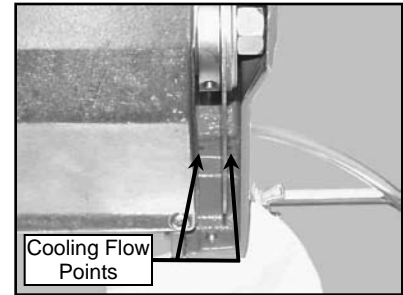

(C)
Run the MK-660 until clear water
is seen at the blade cooling ports
(Approx. 1 minute)

⚠CAUTION Ensure the saw is disconnected before completing the remainder of the cleanup process.

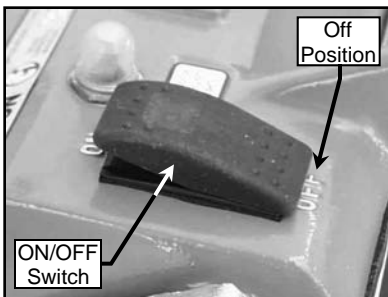

(D)
Ensure the ON/OFF Switch is
in the OFF position

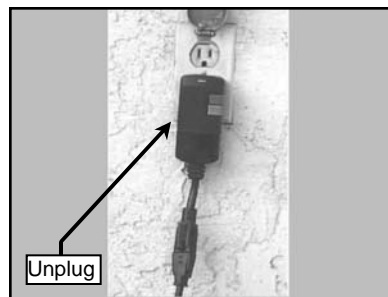

(E)
Unplug the GFCI from the
Power source

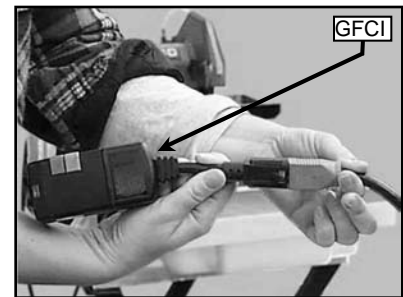

(F)
Unplug MK-660 from the GFCI

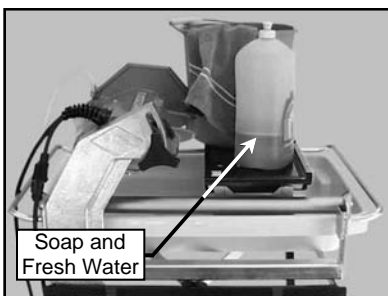

(G)
Clean the MK-660 with soap
and clean water

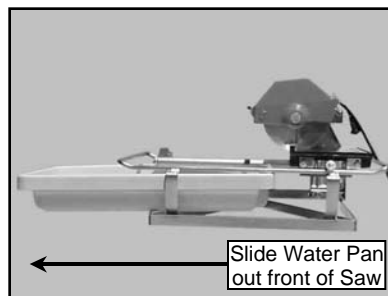

(H)
Remove the Water Pan from
the MK-660

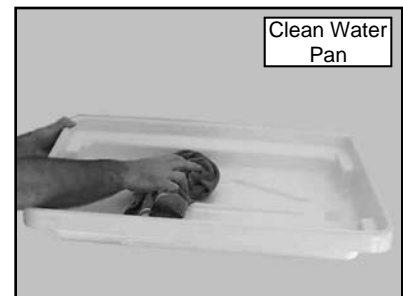

(I)
Clean the Water Pan

SETUP, ADJUSTMENT and OPERATION

⚠CAUTION Ensure water is not forced into the motor casing when cleaning.

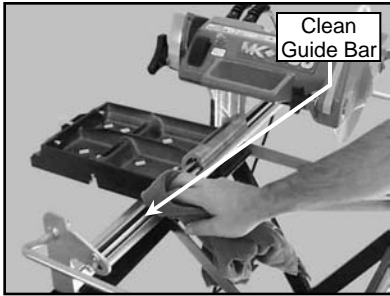

(J)
Clean the Movable Cutting
Table Guide Bar

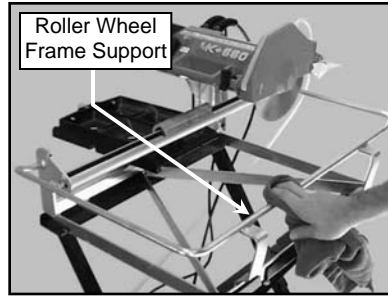

(K)
Clean the Movable Cutting
Table Roller Wheel Frame
Support

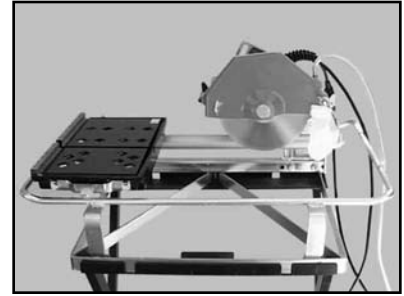

(L)
Clean the remainder of the
MK-660

MAINTENANCE AND TROUBLESHOOTING

MAINTENANCE:

1. Maintenance Following Use:

To extend the life of the MK-660, the following procedure should be performed after each use. Lubricate all points listed below with light oils such as, 3 in 1, WD-40, etc.

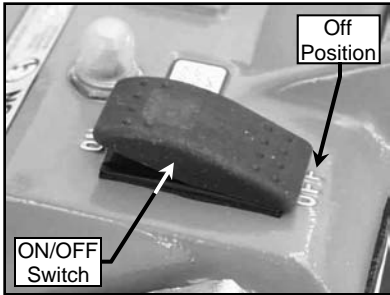

(A)
Ensure the ON/OFF Switch is in the OFF position

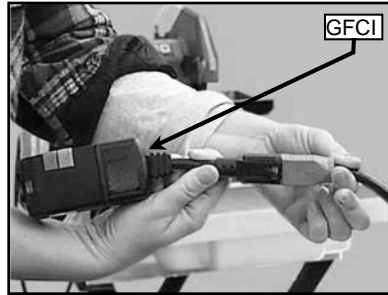

(B)
Unplug MK-660

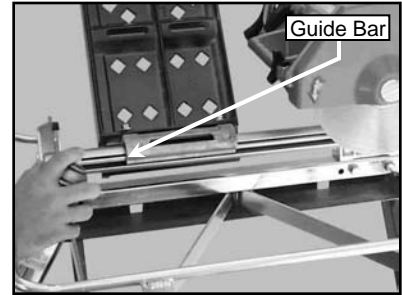

(C)
Lubricate the Guide Bar

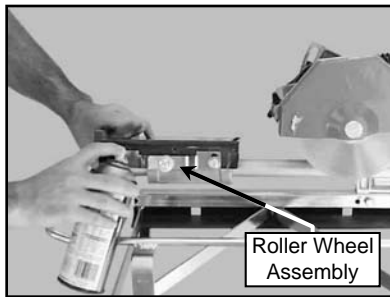

(D)
Lubricate the Roller Wheel Assembly

2. Monthly Maintenance:

The following maintenance should be performed Monthly.

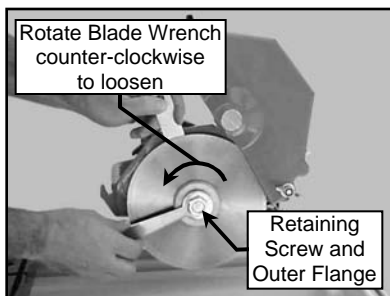

(A)
Remove the Diamond Blade

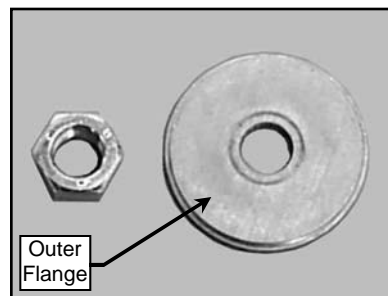

(B)
Lubricate the Outer Flange and Retaining-nut

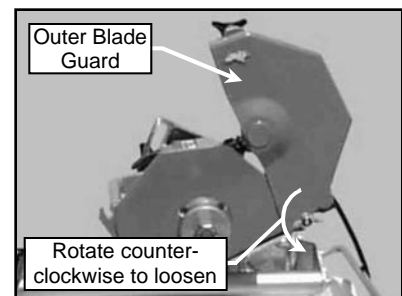

(C)
Remove the Outer Blade Guard

MAINTENANCE AND TROUBLESHOOTING

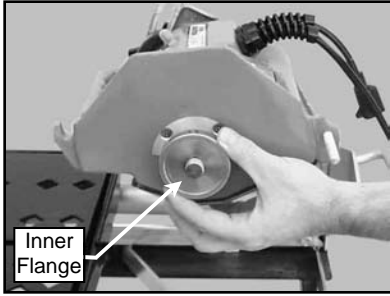

(D)
Remove the Inner Flange

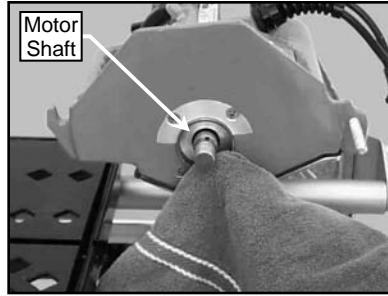

(E)
Clean around the Motor Shaft
and clean the Inner Flange

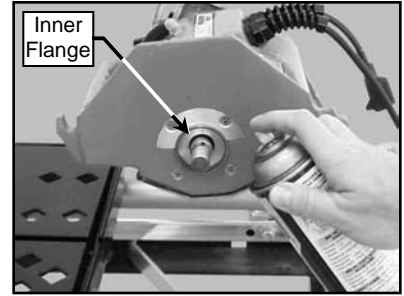

(F)
Lubricate the Motor Shaft and
Inner Flange

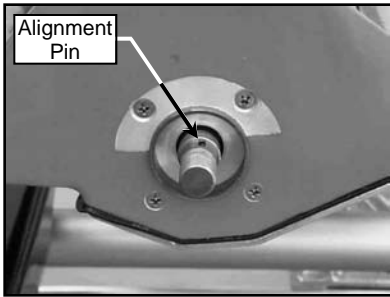

(G)
Locate the Motor Shaft
Alignment Pin

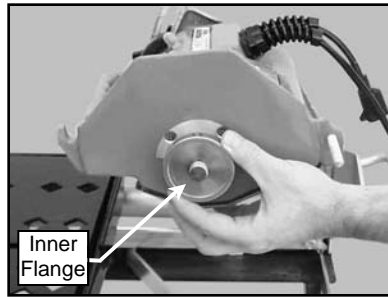

(H)
Align the Alignment Slot of the
Inner Flange to the Motor Shaft
Alignment Pin and Install the
Inner Flange

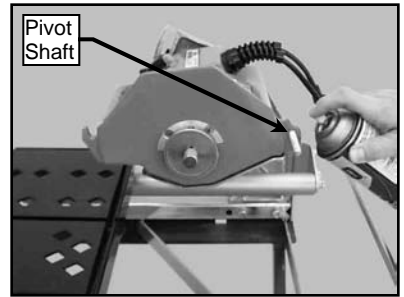

(I)
Lubricate the Outer Blade
Guard Pivot Shaft

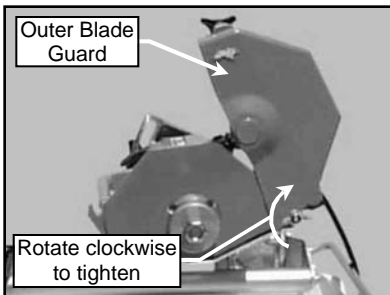

(J)
Install the Outer Blade Guard

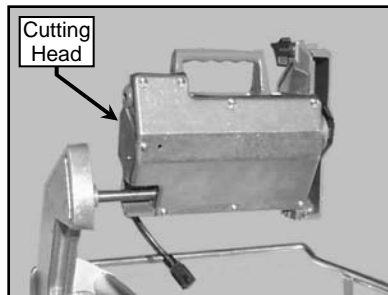

(K)
Remove the Cutting Head

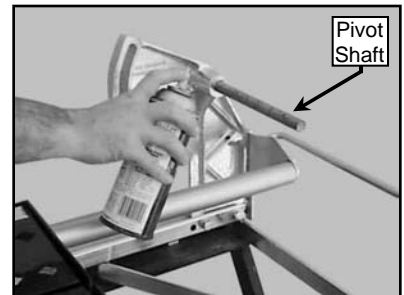

(L)
Lubricate the Cutting Head
Pivot Shaft

MAINTENANCE AND TROUBLESHOOTING

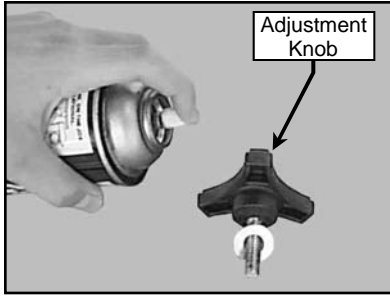

(M)
Lubricate the Cutting Head
Adjustment Knob

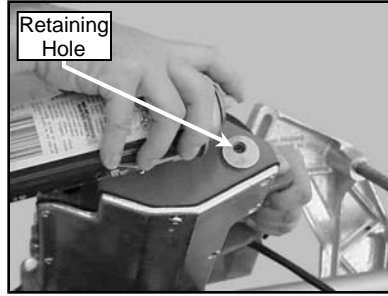

(N)
Lubricate the Cutting Head
Adjustment Knob retaining
holes

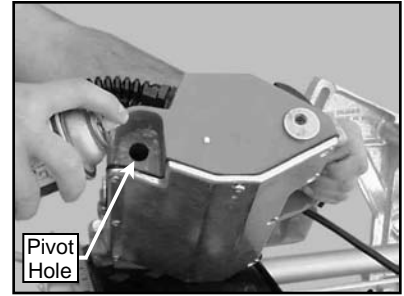

(O)
Lubricate the Cutting Head
Pivot Hole

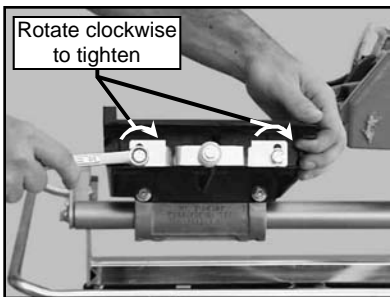

(P)
Verify the Cutting Table Roller
Wheel Assembly is tight

3. Flow Adjustment:

NOTE: If flow to the diamond blade requires adjustment, perform the following actions.

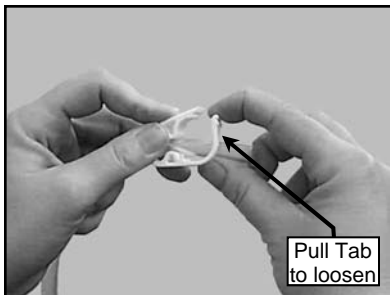

(A)
Increase cooling flow by
releasing the Flow Adjusting
Clamp

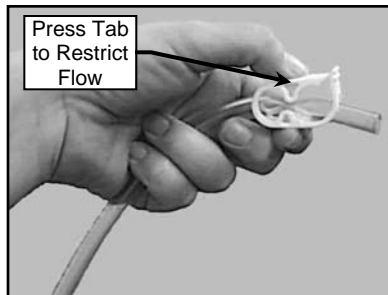

(B)
Reduce cooling flow by
Pressing down on the Flow
Adjusting Clamp

MAINTENANCE AND TROUBLESHOOTING

4. Blade Dressing:

Like most cutting instruments, a diamond blade performs best when it is dressed. Over time and use, diamonds on the outer edge of the blade will become smoothed or “glazed” over. This will reduce grinding efficiency and may cause the blade to “wander” or bend giving the illusion of an alignment problem. When this occurs, the blade will need to be dressed. The diamond blade can be dressed using the MK Dressing Stick (part number 152972) and by following the steps below.

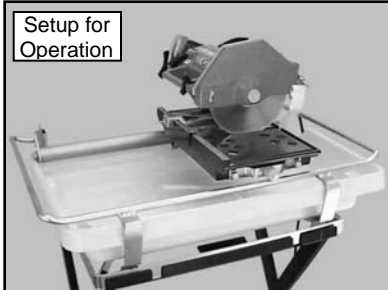

(A)
Setup the MK-660 for operation (See Setup, Adjustment and Operation)



(B)
Set the Adjustable Cutting Guide to cut a 1/16-strip

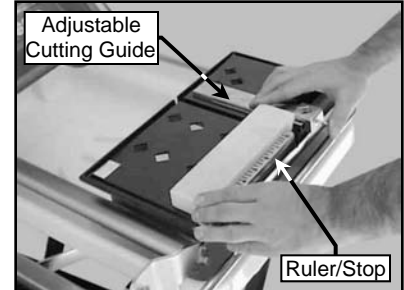

(C)
Position the Dressing Stick

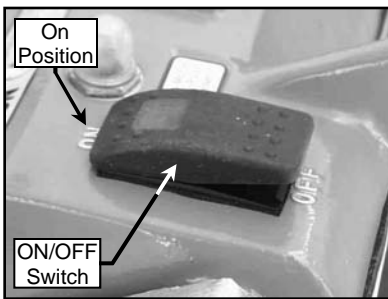

(D)
Turn the motor ON

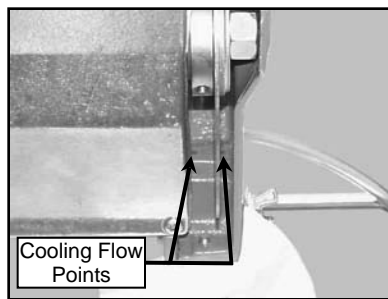

(E)
Verify cooling flow on both sides of the blade (See Maintenance Section to adjust flow)

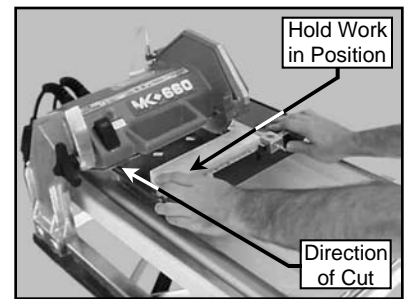

(F)
Cut the Dressing Stick 7 or 8 times to dress the Blade

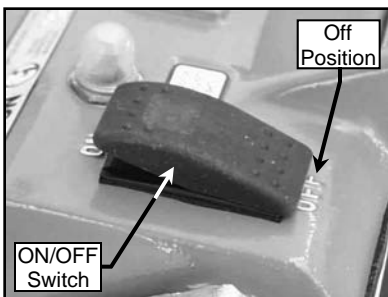

(G)
Ensure the ON/OFF Switch is in the OFF position

MAINTENANCE AND TROUBLESHOOTING

5. Diamond Blade Change-out:

NOTE: When installing the Retaining Screw, do not "cross-thread" and DO NOT over tighten the screw.

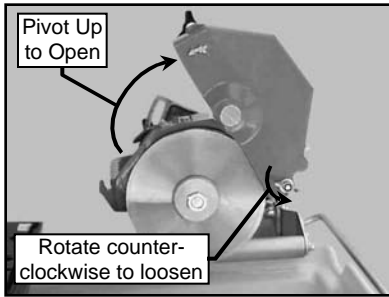

(A)
Open the Outer Blade

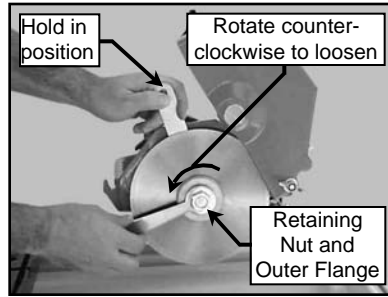

(B)
Remove Retaining Nut and
Outer Flange

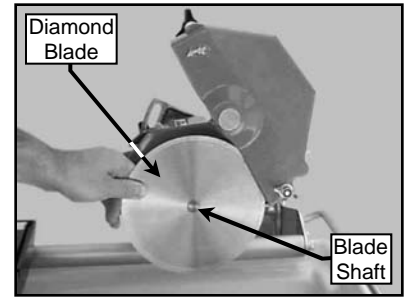

(C)
Remove Diamond Blade from
Blade Shaft

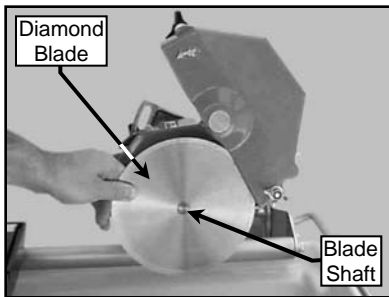

(D)
Install the Diamond Blade onto
Blade Shaft

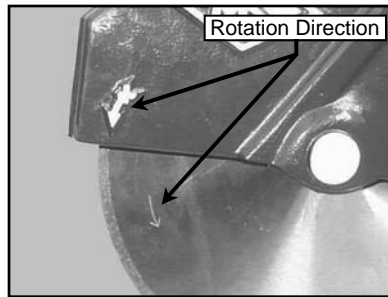

(E)
Verify the Blade is seated on
the Blade Shaft and direction of
rotation is correct

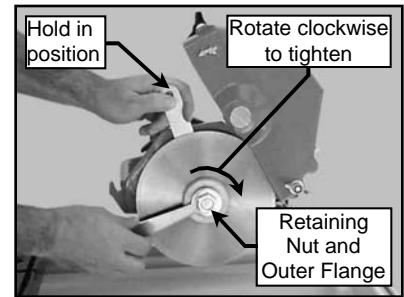

(F)
Install the Retaining Nut and Outer
Flange, Hold the Shaft using the
Inner Flange Retaining Wrench and
tighten using the Blade Wrench

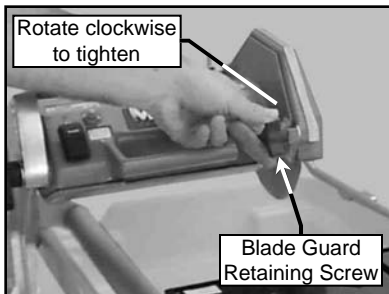

(H)
Close the Outer Blade Guard
and tighten the Blade Guard
Retaining Screw

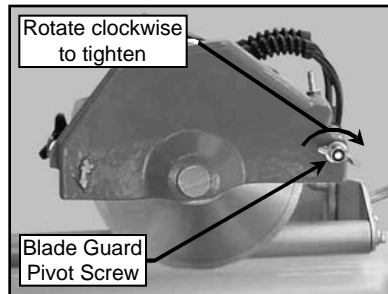

(I)
Tighten the Outer Blade Guard
Pivot Screw

MAINTENANCE AND TROUBLESHOOTING

TROUBLESHOOTING:

1. Blade will not cut properly:



(A)
Check for Smoothness or
"Glazing" (Dress blade if
needed)

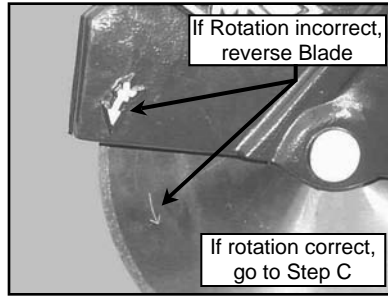

(B)
Check for proper rotation



(C)
Ensure the Blade Core is not
bent and Arbor is not out of
round



(D)
Verify the blade is correct for
the material being used

**Return to
MK Diamond
for Repair**

(E)
Return to MK Diamond

2. Movable Cutting Table Does Not Move Correctly:

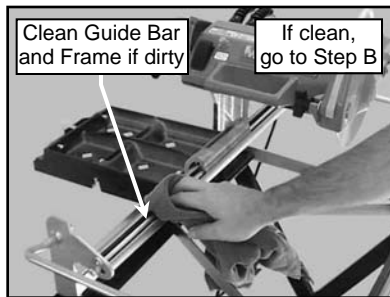

(A)
Check that the Guide Bar are
clean – clean if dirty

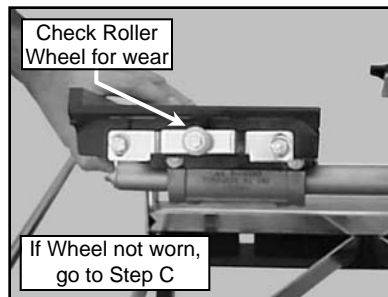

(B)
Check the Movable Cutting
Table Roller Wheels for wear
replace if necessary

**Return to
MK Diamond
for Repair**

(C)
Return to MK Diamond

MAINTENANCE AND TROUBLESHOOTING

3. Cooling Flow:

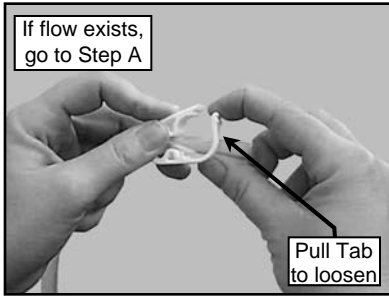

(A)
Check cooling flow Adjusting
Clamp open

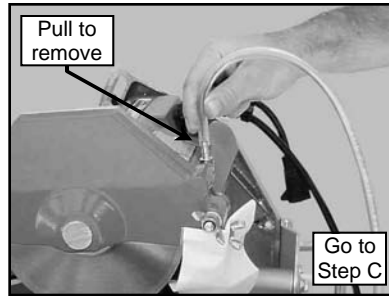

(B)
Remove the Cooling Transfer
Tube from the Blade Guard
inlet

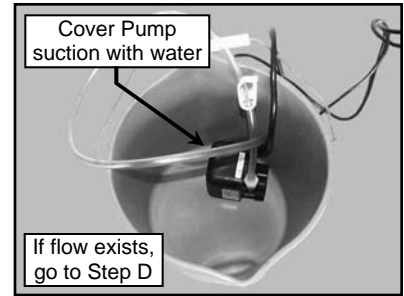

(C)
Place Pump into a bucket of
water and check flow

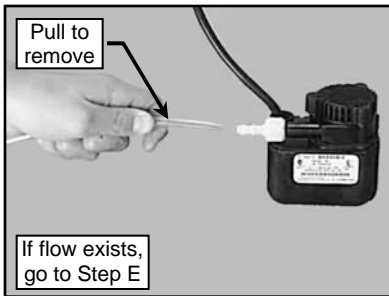

(D)
Remove the Cooling Transfer
Tube and check flow

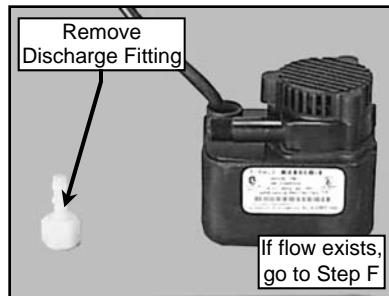

(E)
Remove the Pump Discharge
Fitting and check

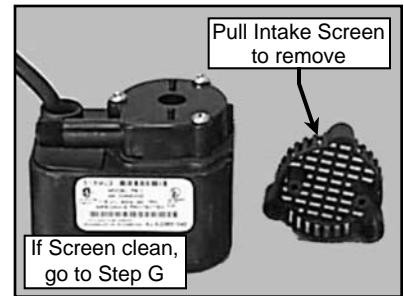

(F)
Remove the Pump Intake
Screen and check for debris

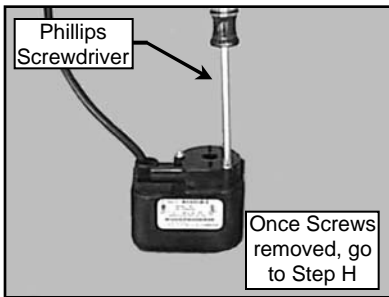

(G)
Remove the 3 Pump Casing
Retaining Screws

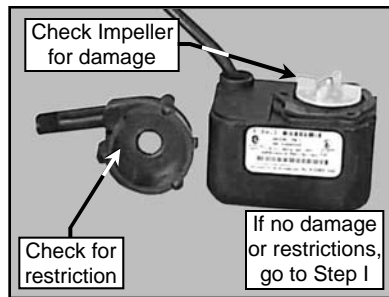

(H)
Remove the Pump Casing and
check for restriction; check
Impeller damage

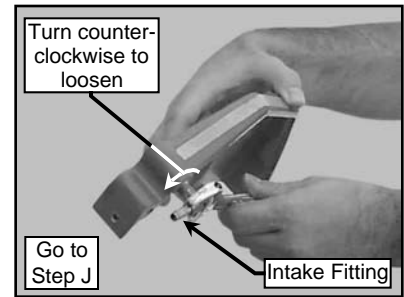

(I)
Remove the Blade Guard
Intake Fitting

MAINTENANCE AND TROUBLESHOOTING

NOTE: "Rodding" cooling channels is performed by inserting a small wire rod through the cooling inlet on top of the Blade Guard and directing the rod out through each of the cooling flow tubes located on the underside of the Blade Guard. The cooling channels should be "rodded" until all ports are free of foreign debris.

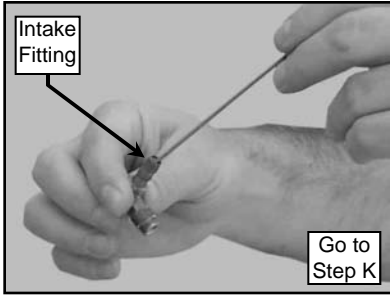

(J)
Clean the Blade Guard Intake Fitting

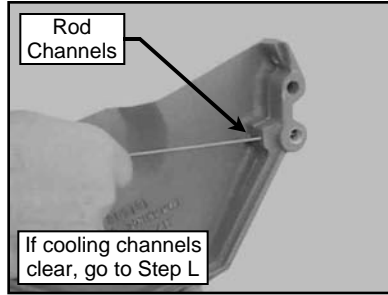

(K)
Rod Cooling Channels and recheck flow

**Return to
MK Diamond
for Repair**

(L)
Return to MK Diamond

MAINTENANCE AND TROUBLESHOOTING

4. Blade Stops Turning:



(A)

Allow motor to cool and depress motor Overload Reset Switch

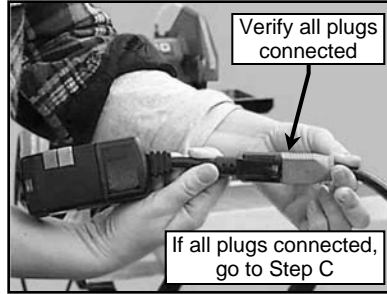

(B)

Verify all plugs fully installed

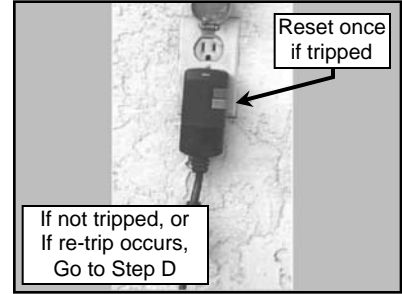

(C)

Check Ground Fault Circuit Interrupter (GFCI) tripped

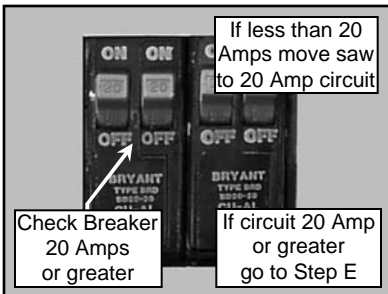

(D)

Verify circuit breaker at least 20 amps – if not, move to 20-amp circuit

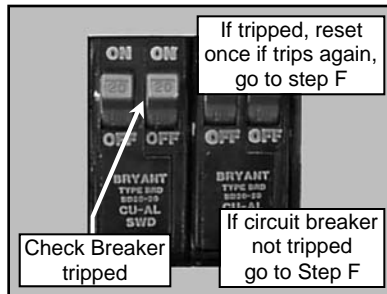

(E)

Verify circuit breaker not tripped If tripped, reset once

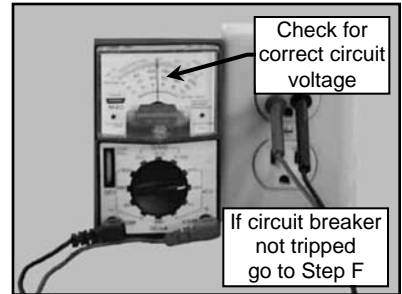

(F)

Check power source voltage is 115V – if not 115v, move to another circuit

**Return to
MK Diamond
for Repair**

(G)

Return to MK Diamond

EXPLODED VIEW AND PARTS LIST

EXPLODED VIEW:

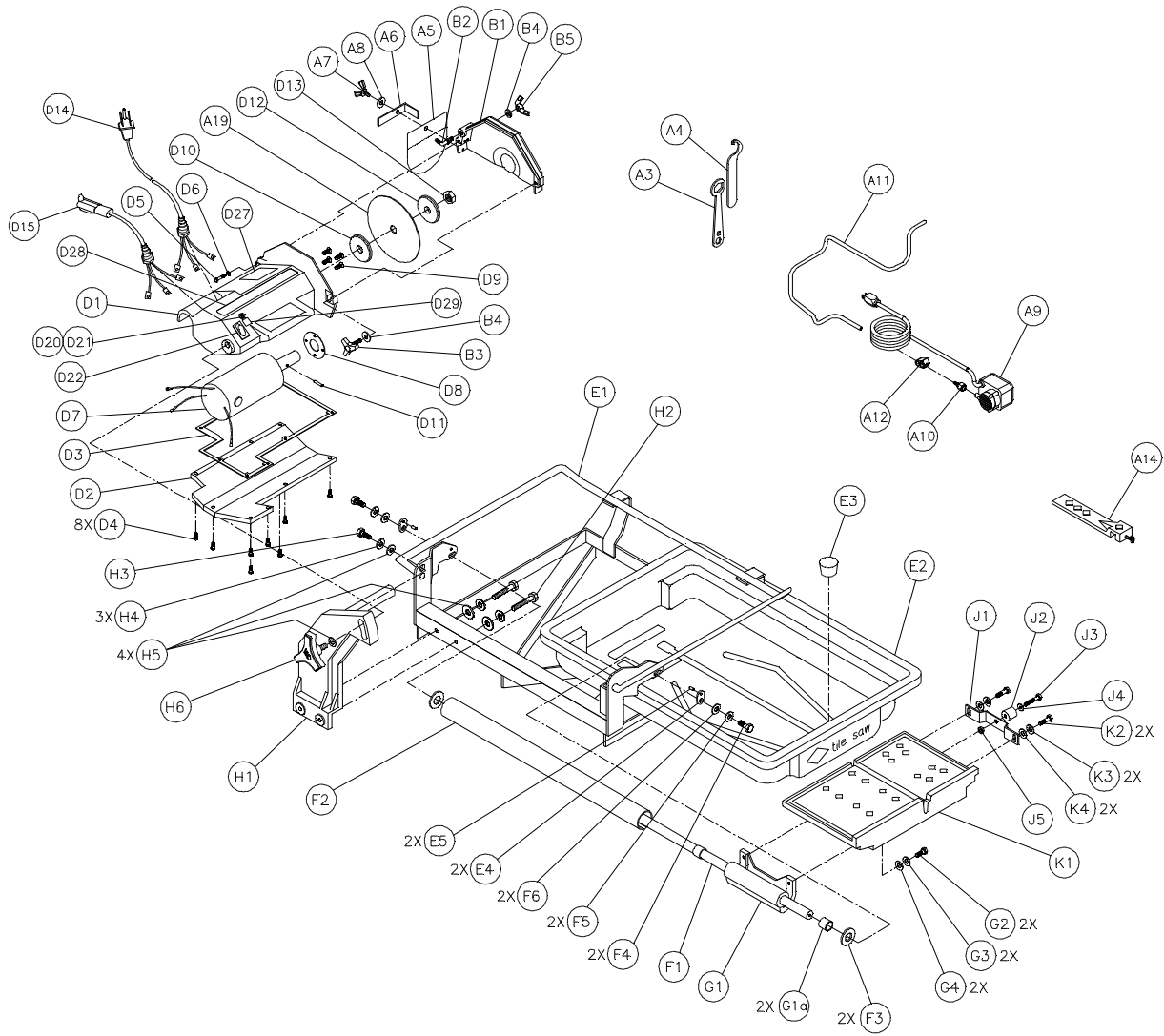

EXPLODED VIEW AND PARTS LIST

PARTS LIST:

Item	Description	Qty	Part #
A	Accessories	1	n/a
A1	Carton, Accessory Pack, 660	1	153498
A3	Wrench, 15/16 Closed End	1	134684
A4	Wrench, Spanner, 660	1	154362
A5	Curtain, Splash	1	134841
A6	Bracket, Splash Curtain	1	152571
A7	Wing-screw, 1/4-20 x 1/2	1	151888
A8	Washer, 1/4 SAE Flat	1	151915
A9	Pump, Water, G-150A	1	151271
A10	Fitting, Plastic, 1/4 FNPT x 1/4 BARB	1	128397
A11	Hose, Vinyl, 1/4 ID	2'	132951
A12	Clamp, Flow, 1/4-1/2	1	154394
A13	Owner's Manual, Water Pump	1	155745
A14	Rip Guide	1	134551
	Screw, 1/4-20 x 3/4 Thumb	1	150991
A15	Large Bullnose Accessory	1	153201
	Screw, 1/4-20 x 3/4 Thumb	2	150991
A16	Owner's Manual, 660	1	153461
A19	Blade, 7 x 060 x 5/8, MK-100	1	153441
B	Blade Guard, 7", Assembly	1	154811-MK
B1	Guard, 7"Blade	1	151731
B2	Elbow, 1/8 MNPT x 1/4 BARB 90° Brass	1	154652
B3	Knob, Davies	1	151681
B4	Washer, 5/16 SAE Flat	2	151754
B5	Wing-nut, 5/16-18 Nylock	1	151746
D	Cutting Head (less blade guard)	1	n/a
D1	Cutting Head, 660	1	154291
D2	Cover, Cutting Head, 660	1	154293
D3	Gasket, Cover, 660	1	154381
D4	Screw, 10-24 x 5/8 Pan Head Phillips Self-Tapping Machine	8	153681
D5	Screw, 5/16-18 x 2 1/2 Hex Head Cap, Fully Threaded	1	151748
D6	Washer, 5/16 Split Lock	1	151747
D7	Motor, 3/4 HP 115V FWR, 660	1	154292
D7A	Motor, 3/4 HP 230V FWR, 660	1	153497
D8	Gasket, Thermal, 660	1	154346
D9	Screw, 10-24 x 5/8 Flat Head Phillips Machine	4	154295
D10	Flange, Inner, 660	1	154194
D11	Pin, 1/8 x 3/8 Spring	1	154982
D12	Flange, Outer	1	135830
D13	Nut, 5/8-18 UNF Hex	1	135848
D14	Cord, AC Power 120V (16/3 SJTW x 10', w/ molded 5-15P and Heyco 3251 Strain Relief)	1	153419
D15	Cord, Pump Pigtail, 16/3 SJTW x 1', w/ molded 5-15R and Heyco 3251 Strain Relief	1	154446
D16	Wire Harness, 660	1	153415
D17	Screw, 10-24 x 3/8 Pan Head Phillips Self-Tapping Machine	1	151262
D18	Resistor, 660	1	153535
D19	Tack, 1/4 Head	4	155659
D20	Switch, Thermal Overload, 660	1	153420

EXPLODED VIEW AND PARTS LIST

Item	Description	Qty	Part #
D21	Boot, Thermal Overload Switch	1	154468
D22	Switch, 15A\125V Lighted Rocker	1	156917
D23	Rectifier, 40 Amp	1	153677
D24	Screw, 10-24 x 3/4 Fillister Head Machine	1	151750
D25	Wire-nut, 3/#16 AWG (Blue)	1	155492
D26	Tag, 660 Serial Number	1	156561
D27	Label, Caution Strip	1	155214
D28	Label, When Motor Cools...	1	154409
E	Frame	1	n/a
E1	Frame	1	153322
E2	Pan, Plastic	1	151736
E3	Plug, Water Drain	1	153439
E4	Plate, Adjustment	2	151758
E5	Pin, Rolled	2	151783
F	Guide Bar, 5/8 Dia.	1	151739-MK
F1	Bar, Guide, 5/8 Dia.	1	151739
F2	Cover, Guide Bar	1	151740
F3	Spacer, 5/8 Guide Bar Cover	2	151755
F4	Screw, 5/16-18 x 1 Hex Head Cap	2	151743
F5	Washer, 5/16 Split Lock	2	151747
F6	Washer, 5/16 SAE Flat	2	151754
G	Linear Bearing	1	151737-MK
G1	Casting, Bearing, Linear	1	151737
G1a	Bearing, Multi-Lube	2	157126
G2	Screw, 5/16-18 x 1 Hex Head Cap	2	151743
G3	Washer, 5/16 Split Lock	2	151747
G4	Washer, 5/16 SAE Flat	2	151754
H	Post	1	n/a
H1	Post, Rear, 660	1	153451
	Shaft, 5/8 Pivot, 660	1	153452
H2	Screw, 3/8-16 x 2 Hex Head Cap	2	153485
H3	Screw, 3/8-16 x 1 Hex Head Cap	1	152507
H4	Washer, 3/8 Split Lock	3	150925
H5	Washer, 3/8 SAE Flat	4	150923
H6	Knob, 3/8-16 x 1-1/2 MK Adjustment	1	156770-02
J	Roller Wheel	1	151756
J1	Bracket, Roller Wheel	1	154021
J2	Wheel, Roller	1	151799
J3	Screw, 1/4-20 x 1 1/2 Hex Head Cap	1	151914
J4	Washer, 1/4 SAE Flat	1	151915
J5	Nut, 1/4-20 Hex	1	151893
K	Table, 660	1	n/a
K1	Table, 660	1	152680
K2	Screw, 5/16-18 x 1 Hex Head Cap	2	151743
K3	Washer, 5/16 Split Lock	2	151747
K4	Washer, 5/16 SAE Flat	2	151754

THEORY

THEORY OF DIAMOND BLADES:

Diamond blades do not really cut; they grind the material through friction. Diamond crystals, often visible at the leading edge and sides of the rim/segment, remove material by scratching out particles of hard, dense materials, or by knocking out larger particles of loosely bonded abrasive material. This process eventually cracks or fractures the diamond particle, breaking it down into smaller pieces. As a result, a diamond blade for cutting soft, abrasive material must have a hard metal matrix composition to resist this erosion long enough for the exposed diamonds to be properly utilized. Conversely, a blade for cutting a hard, non-abrasive material must have a soft bond to ensure that it will erode and expose the diamonds embedded in the matrix. These simple principles are the foundation of “controlled bond erosion”.



Types of Cutting:

There are two basic types of cutting-Dry or Wet. The choice of which type of blade to use depends on:

- The requirements of the job
- The machine/tool utilizing the diamond blade
- The preference of the operator









In the case of DRY cutting, the overwhelming popularity and quantity of hand-held saws and the flexible nature of MK Diamond blades to professionally handle most ceramic, masonry, stone and concrete materials, make the DRY cutting blade a very attractive tool. When using a DRY blade, the user must be aware of distinct operating practices to ensure optimum performance. DRY cutting blades require sufficient airflow about the blade to prevent overheating of the steel core. This is best accomplished by shallow, intermittent cuts of the material with periods of “free-spinning” (for several seconds) between each cut, to maximize the cooling process.

For WET cutting applications, MK has the exact blade to compliment both the material to be cut and the wet cutting machine to be used. During cutting operations, liberal amounts of water act as a coolant to support the cutting effectiveness and longevity of the WET blade. Additionally, using water adds to the overall safety of cutting operations by keeping the dust signature down.

Know All You Can About the Material You Wish to Cut

ACCESSORIES

ACCESSORIES:

ITEM	NUMBER	DESCRIPTION	
1.	139292	MK-200, 7 x 5/8 Arbor	
2.	139311	MK-215, 7 x 5/8 Arbor	
3.	153293	MK-315, 10 x 5/8 Arbor	
4.	134577	Dual 45° Flat Angle Guide	
5.	134585 (small) or 153201 (large)	45° Bullnose Miter	
6.	134569	90° Protractor	
7.	152792	Dressing Stone	
8.	152610	Ground Fault Circuit Interrupter	
9.	151889	Universal Stand	

ORDERING and RETURN INFORMATION

ORDERING INFORMATION:

You may order MK Diamond products through your local MK Diamond distributor or, you may order direct from MK Diamond.

NOTE: There is a \$25.00 minimum order when ordering direct from MK Diamond. All purchases must be made using VISA or MasterCard.

When ordering direct from MK Diamond, please have the following information ready before calling:

- The Model Number of the saw
- The Serial Number of the saw
- Where the saw was purchased and when
- The Part Number for the part(s) being ordered
- The Part Description for the part(s) being ordered

All parts may be ordered by calling toll free to – **800 421-5830** or **310 539-5221** and asking for Customer Service. For technical questions, call – **800 474-5594**.

RETURN MATERIALS POLICY:

To expedite the service relative to the return of a product purchased through MK Diamond, please observe the following:

NOTE: When returning all items, they must have been purchased within the previous twelve (12) months.

- Have the Model Number of the saw
- Have the Serial Number of the saw
- Have the location of where the saw was purchased
- Have the date when the saw was purchased
- Contact Customer Service for approval to return the item(s)
- Obtain a Returned Goods Number (RGA) authorizing the return
- Follow the packaging instructions in the following section
- Ensure your item(s) are prepaid to the destination

For returned items, call toll free to – **800 421-5830** or **310 539-5221** and ask for Customer Service. For technical questions, call – **800 474-5594** or **310 257-2845**.

PACKAGING INSTRUCTIONS:

- Remove the Blade guard and Support Angle Assembly
- Dry the saw before shipping
- When packing, include the following: MK-660, Diamond Blade, Blade guard and Support Angle Assembly and Adjustable Cutting Guide (Other Accessories are not required)
- Package the unit in its original container or one of comparable size (do not ship the unit partially exposed)
- Ensure all parts are secured in the packaging to prevent moving

AUTHORIZED SERVICE CENTERS:

For quicker repair time, you may contact MK Diamond Customer Service, toll free, at – **800 421-5830** or **310 539-5221** for the Authorized Service Center closest to you. For technical questions, call – **800 474-5594**.

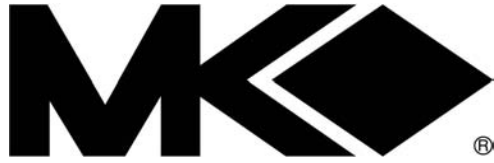

MK-660 SERIES

TILE SAW OWNER'S MANUAL & OPERATING INSTRUCTIONS

CALIFORNIA PROPOSITION 65 MESSAGE:

⚠WARNING

Some dust created by power sanding, sawing, grinding, drilling, and other construction activities contain chemicals known [to the State of California] to cause cancer, birth defects or other reproductive harm. Some examples of these chemicals are:

- Lead, from lead-based paints
- Crystalline silica, from bricks and cement and other masonry products and
- Arsenic and chromium, from chemically treated lumber

Your risk from these exposures varies depending on how often you do this type of work. To reduce your exposure to these chemicals, work in a well-ventilated area, and work with approved safety equipment, such as those dust masks that are specially designed to filter out microscopic particles.

MK DIAMOND PRODUCTS, INC
1315 STORM PARKWAY, TORRANCE, CA 90509-2803
310 539 5158