

# MK-370 EXP TILE SAW

## OWNERS MANUAL



### TILE SAW OWNER'S MANUAL & OPERATING INSTRUCTIONS



#### CAUTION

READ SAFETY  
AND GENERAL  
INSTRUCTIONS  
CAREFULLY  
BEFORE USING  
SAW FOR THE  
FIRST TIME



### SERIAL NUMBER

YOU SHOULD RECORD THE SERIAL NUMBER OF YOUR SAW ON THIS OWNER'S MANUAL AND ON THE WARRANTY CARD, WHICH MUST BE SENT IN, TO BE EFFECTIVE. BE SURE TO INCLUDE ALL PERTINENT INFORMATION REQUIRED.

## **SAFETY INSTRUCTIONS FOR THE MK-370 EXP TILE SAW**

Congratulations on your purchase of a MK-370 EXP Tile Saw. We are certain that you will be pleased with your purchase. MK Diamond takes pride in producing the finest construction power tools and diamond blades in the industry.

Operated correctly, your MK-370 EXP should provide you with years of service. In order to help you, we have included this manual. This owners manual contains information necessary to operate and maintain your MK-370 EXP safely and correctly. Please take a few minutes to familiarize yourself with the MK-370 EXP by reading and reviewing this manual.

If you should have questions concerning your MK-370 EXP, please feel free to call our friendly customer service department at: 800 421-5830

Regards,

MK Diamond

**SAFETY**

DAMAGE PREVENTION AND INFORMATION MESSAGES: \_\_\_\_\_ 4  
 SAFETY MESSAGES \_\_\_\_\_ 4  
 GENERAL SAFETY PRECAUTIONS AND HAZARD SYMBOLS \_\_\_\_\_ 4  
 CALIFORNIA PROPOSITION 65 MESSAGE \_\_\_\_\_ 6  
 ELECTRICAL REQUIREMENTS AND GROUNDING INSTRUCTIONS \_\_\_\_\_ 8  
 TILE SAW SPECIFIC WARNINGS: \_\_\_\_\_ 10  
 SAFETY LABEL LOCATIONS \_\_\_\_\_ 10  
 PRODUCT SPECIFICATIONS \_\_\_\_\_ 11

**UNPACKING, TRANSPORT, STAND and ASSEMBLY**

UNPACKING \_\_\_\_\_ 12  
 CONTENTS \_\_\_\_\_ 12  
 TRANSPORT \_\_\_\_\_ 12  
 TILE SAW STAND \_\_\_\_\_ 13  
 ASSEMBLY \_\_\_\_\_ 14

**SETUP, ADJUSTMENT & OPERATION**

SETUP \_\_\_\_\_ 17  
 ADJUSTMENT & OPERATION \_\_\_\_\_ 20  
 CLEANUP \_\_\_\_\_ 25

**MAINTENANCE AND TROUBLESHOOTING**

MAINTENANCE \_\_\_\_\_ 27  
 ALIGNMENT \_\_\_\_\_ 32  
 TROUBLESHOOTING \_\_\_\_\_ 37

**EXPLODED VIEW AND PARTS LIST**

EXPLODED VIEW \_\_\_\_\_ 40  
 PARTS LIST \_\_\_\_\_ 41

**THEORY**

THEORY OF DIAMOND BLADES \_\_\_\_\_ 43

**ACCESSORIES**

ACCESSORIES \_\_\_\_\_ 44

**ORDERING & RETURN INSTRUCTIONS**

ORDERING INFORMATION \_\_\_\_\_ 45  
 RETURN MATERIALS POLICY \_\_\_\_\_ 45  
 PACKAGING INSTRUCTIONS \_\_\_\_\_ 45  
 AUTHORIZED SERVICE CENTERS \_\_\_\_\_ 45

# SAFETY

Read and follow all safety, operating and maintenance instructions. Failure to read and follow these instructions could result in injury or death to you or others. Failure to read and follow these instructions could also result in damage and/or reduced equipment life.

## SAFETY MESSAGES:

Safety messages inform the user about potential hazards that could lead to injury, death and/or equipment damage. Each safety message will be preceded by one of the following (3) three words that identify the severity of the message.



### **DANGER**

Not following instructions WILL lead to DEATH or SERIOUS INJURY



### **WARNING**

Not following instructions COULD lead to DEATH or SERIOUS INJURY



### **CAUTION**

Not following instructions CAN lead to injury.

## DAMAGE PREVENTION AND INFORMATION MESSAGES:

A Damage Prevention Message is to inform the user of important information and/or instructions that could lead to equipment or other property damage if not followed. Information Messages convey information that pertains to the equipment being used. Each message will be preceded by the word NOTE, as in the example below.

**NOTE:** Equipment and/or property damage may result if these instructions are not followed.

## GENERAL SAFETY PRECAUTIONS AND HAZARD SYMBOLS:

In order to prevent injury, the following safety precautions and symbols should be followed at all times!

### Safety Precautions:



### **READ OWNERS MANUAL BEFORE USE**



Before using this equipment, ensure that the person operating this machine has read and understands all of the instructions in the manual. Precaution is the best insurance against accidents. Read and understand all safety precautions, messages, warnings and hazard symbols. You are responsible for your own safety.



### **KEEP GUARDS IN PLACE**



Adhere to safety guidelines: ANSI American National Standards Institute, OSHA, or local Regulations. Never operate the saw with out the guards in place!



### **REMOVE ADJUSTING KEYS AND WRENCHES**

Form a habit of checking to see that keys and adjusting wrenches are removed from the power tool before it is turned on.



### **KEEP WORK AREA CLEAN**

Cluttered work areas and benches invite accidents.



### **DO NOT USE IN DANGEROUS PLACES**

Do not use power tools in damp or wet locations nor expose them to rain. Always keep the work area well lighted.



### **KEEP CHILDREN AWAY**

All visitors and children should be kept a safe distance from work area.

** MAKE THE WORKSHOP KID PROOF**

Make the workshops kid proof by using padlocks, master switches or by removing starter keys.

** DO NOT FORCE THE TOOL**

A power tool will do a job better and safer operating at the rate for which it was designed.

** USE THE RIGHT TOOL**

Do not force a tool or an attachment, to do a job that it was not designed to do.

** USE THE PROPER EXTENSION CORD**

If using an extension cord make sure it is in good condition first. When using an extension cord, be sure to use one heavy enough to carry the current your product will draw. An undersized cord will cause a drop in line voltage that will result in a loss of power and overheating. TABLE 1, Page 9 shows the correct AWG size to use depending on cord length and nameplate ampere rating. If in doubt, use the next heavier gage. The smaller the gage number, the heavier the cord.

** USE PROPER APPAREL**

Do not wear loose clothing, gloves, neckties, rings, bracelets, or other jewelry that may be caught in moving parts. Non-slip footwear is recommended. Wear protective hair covering to contain long hair.

** ALWAYS USE SAFETY GLASSES**

Safety glasses should always be worn when working around power tools. In addition, a face, dust mask or respirator should be worn if a cutting operation is dusty. Everyday eyeglasses only have impact resistant lenses and may not prevent eye injury-they are NOT safety glasses.

** SECURE WORK**

Clamps or a vise should be used to hold work whenever practical. Keeping your hands free to operate a power tool is safer.

** DO NOT OVERREACH**

Keep proper footing and balance at all times by not overreaching.

** MAINTAIN TOOLS WITH CARE**

Keep tools clean for the best and safest performance. Always follow maintenance instructions for lubricating, and when changing accessories.

** DISCONNECT TOOLS**

Power tools should always be disconnected before servicing or when changing accessories, such as blades, bits, cutters, and the like.

** REDUCE THE RISK OF UNINTENTIONAL START**

Make sure the ON/OFF switch is in the OFF position before plugging in a power tool.

# SAFETY



## USE RECOMMENDED ACCESSORIES

Consult the owner's manual for recommended accessories. Using improper accessories may increase the risk of personal or by-stander injury.



## NEVER STAND ON THE TOOL

Serious injury could occur if a power tool is tipped, or if a cutting tool is unintentionally contacted.



## CHECK FOR DAMAGED PARTS

Before using a power tool, check for damaged parts. A guard or any other part that is damaged should be carefully checked to determine it would operate properly and perform its intended function. Always check moving parts for proper alignment or binding. Check for broken parts and mountings and all other conditions that may affect the operation of the power tool. A guard, or any damaged part, should be properly repaired or replaced.



## DIRECTION OF FEED

Always feed work into a blade or cutter against the direction of rotation. A blade or cutter should always be installed such that rotation is in the direction of the arrow imprinted on the side of the blade or cutter.



## NEVER LEAVE A TOOL UNATTENDED

TURN POWER OFF - Do not leave a tool until it comes to a complete stop. Always turn a power tool OFF when leaving the work area, or, when a cut is finished.

## CALIFORNIA PROPOSITION 65 MESSAGE:



### WARNING

Some dust created by power sanding, sawing, grinding, drilling, and other construction activities contain chemicals known [to the State of California] to cause cancer, birth defects or other reproductive harm. Some examples of these chemicals are:

- Lead, from lead-based paints
- Crystalline silica, from bricks and cement and other masonry products and
- Arsenic and chromium, from chemically treated lumber

For further information, consult the following sources:

<http://www.osha-slc.gov/sltc/silicacrystalline/index.html>

[http://www.oehha.org/prop65/out\\_of\\_date/6022kLstA.html](http://www.oehha.org/prop65/out_of_date/6022kLstA.html)

Your risk from these exposures varies depending on how often you do this type of work. To reduce your exposure to these chemicals, work in a well-ventilated area, and work with approved safety equipment, such as those dust masks that are specially designed to filter out microscopic particles.

**Hazard Symbols:** **Electrical Shock!**

Never touch electrical wires or components while the engine is running. They can be sources of electrical shock which could cause severe injury or burns.

 **Rotating Parts!**

Keep hands, feet, hair, and clothing away from all moving parts to prevent injury. Never operate the engine with covers, shrouds, or guards removed.

 **Over Speed!**

Never tamper with the governor components or settings to increase the maximum speed. Severe personal injury and damage to the engine or equipment can result if operated at speeds above maximum.

 **WARNING** Sawing and drilling generates dust. Excessive airborne particles may cause irritation to eyes, skin and respiratory tract. To avoid breathing impairment, always employ dust controls and protection suitable to the material being sawed or drilled; See OSHA (29 CFR Part 1910.1200). Diamond Blades improperly used are dangerous. Comply with American National Standards Institute Safety Code, B7.1 and, Occupational Safety and Health Act covering Speed, Safety Guards, Flanges, Mounting Procedures, General Operating Rules, Handling, Storage and General Machine Conditions

## SAFETY

### ELECTRICAL REQUIREMENTS AND GROUNDING INSTRUCTIONS:

In order to prevent potential electrical shock and injury, the following electrical safety precautions and symbols should be followed at all times!

#### WARNING



In case of a malfunction or breakdown, grounding provides a path of least resistance for electric current to reduce the risk of electric shock. This tool is equipped with an electric cord having an equipment-grounding conductor and a grounding plug. The plug must be plugged into a matching outlet that is properly installed and grounded in accordance with all local codes and ordinances.

- Do not modify the plug provided – if it will not fit the outlet; have the proper outlet installed by a qualified electrician
- Improper connections of the equipment-grounding conductor can result in a risk of electric shock. The equipment-grounding conductor is the insulated conductor that has an outer surface that is green, with or without yellow stripes. If repair or replacement of the electric cord or plug is necessary, do not connect the equipment-grounding conductor to a live terminal
- Check with a qualified electrician or service personnel if the grounding instructions are not completely understood, or if in doubt as to whether the tool is properly grounded
- Use only 3-wire extension cords that have 3-prong grounding plugs and 3-pole receptacles that accept the tool's plug
- Repair or replace a damaged or worn cord immediately

#### WARNING



This tool is intended for use on a circuit that has an outlet that looks like the one shown in Sketch A of Figure 1. The tool has a grounding plug that looks like the plug illustrated in Sketch A of FIGURE 1. A temporary adapter, which looks like the adapter illustrated in sketches B and C, may be used to connect

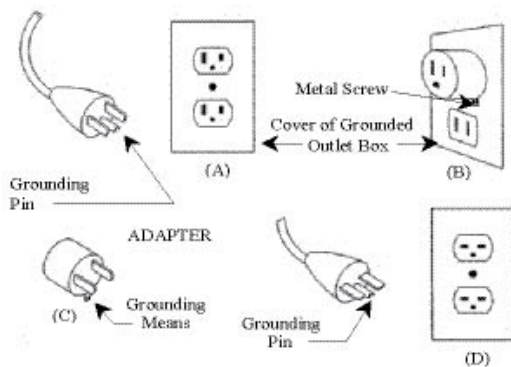

this plug to a 2-pole receptacle as shown in Sketch B, if a properly grounded outlet is not available. The temporary adapter should be used only until a properly grounded outlet can be installed by a qualified electrician. The green-colored rigid ear, lug, and the like, extending from the adapter, must be connected to a permanent ground such as a properly grounded outlet box.

**NOTE:** Use of a temporary adapter is not permitted in Canada

FIGURE 1

#### WARNING

To reduce the risk of electrocution, keep all connections dry and off the ground.

A Ground Fault Circuit Interrupter (GFCI) should be provided on the circuit(s) or outlet(s) to be used for the Saw. Receptacles are available having built-in GFCI protections and may be used for this measure of safety.

When using an extension cord, the GFCI should be installed closest to the power source, followed by the extension cord and lastly, the saw.



To avoid the possibility of the appliance plug or receptacle getting wet, position the saw to one side of a wall mounted receptacle. This will prevent water from dripping onto the receptacle or plug. A “drip loop,” shown in FIGURE 2, should be arranged by the user to properly position the power cord relative to the power source.

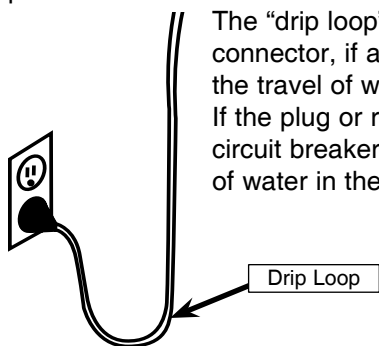

The “drip loop” is that part of the cord below the level of the receptacle, or the connector, if an extension cord is used. This method of positioning the cord prevents the travel of water along the power cord and coming in contact with the receptacle. If the plug or receptacle gets wet, DO NOT unplug the cord. Disconnect the fuse or circuit breaker that supplies power to the tool. Then unplug and examine for presence of water in the receptacle.

FIGURE 2

**⚠ WARNING**



Use only extensions cords that are intended for outdoor use. These extension cords are identified by a marking “Acceptable for use with outdoor appliances; store indoors while not in use.” Use only extension cords having an electrical rating not less than the rating of the product. Do not use damaged extension cords. Examine extension cords before using and replace if damaged. Do not abuse extension cords and do not yank on any cord to disconnect. Keep cords away from heat and sharp edges. Always disconnect the extension cord from the receptacle before disconnection the product form the extension cord.

**⚠ WARNING**

To reduce the risk of electrocution, keep all connections dry and off the ground. Do not touch the plug with wet hands.

**⚠ WARNING**



Use of under size extension cords result in low voltage to the motor that can result in motor burnout and premature failure. MK Diamond warns that equipment returned to us showing signs of being run in a low voltage condition, through the use of undersized extension cords will be repaired or replaced totally at the customers expense. There will be no warranty claim.

To choose the proper extension cord,

- Locate the length of extension cord needed in TABLE 1 below.
- Once the proper length is found, move down the column to obtain the correct AWG size required for that length of extension cord.

Extension Cord Minimum Gage for Length				
Volts	Total Length of Cord in Feet			
120 V	25 ft.	50 ft.	100 ft.	150 ft.
	AWG	AWG	AWG	AWG
	14	12	Not Recommended	

TABLE 1

# SAFETY

## SAFETY LABEL LOCATIONS

Safety labels are located according to Figures 1 through 4 below. The labels contain important safety information. Please read the information contained on each safety label. These labels are considered a permanent part of your saw. If a label comes off or becomes hard to read, contact MK Diamond or your dealer for a replacement

Item	Location	Description	Part No.
1A	Motor – Right Side	Caution – Receptacle is for Water Pump Only	154822
1B	Motor – Right Side	Motor Specifications	N/A
2	Motor – Left Side	Caution – Use with Ground Fault Circuit Interrupter	155678
3A	Cutting Head – Top	MK-370 EXP Serial Number	157249-4
3B	Cutting Head – Top	Warning – Read Owners Manual	155806
4A	Pump – Left Side	Warning – Connect to Grounded Receptacle	N/A
4B	Pump – Right Side	Pump Specifications	N/A

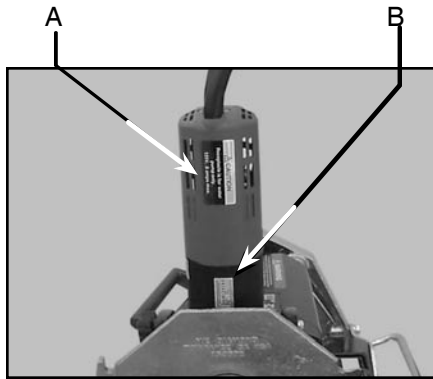
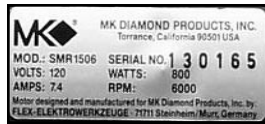
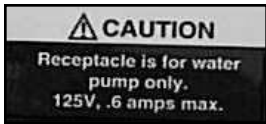

1

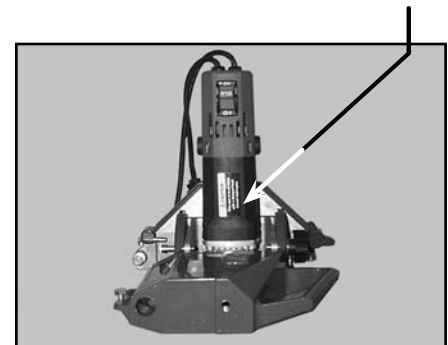

2

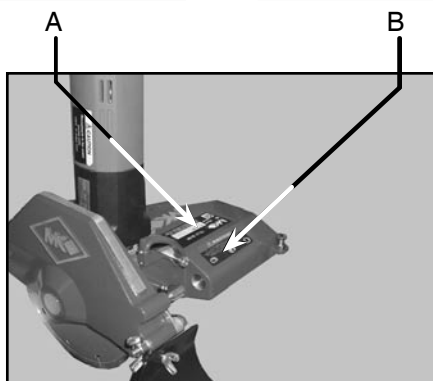

3

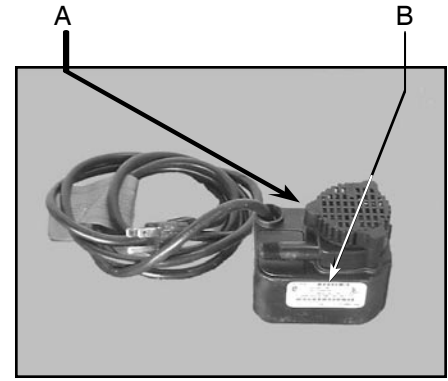

4

## TILE SAW SPECIFIC WARNINGS:



- Wear eye protection.
- Use splash hood for every operation for which it can be used.
- Disconnect saw before servicing, when changing cutting blades, and cleaning.
- Replace damaged cutting blade before operating.

**PRODUCT SPECIFICATIONS**

The MK-370 EXP is a versatile Tile Saw. Operated and used according to this manual, the MK-370 EXP will provide years of dependable service.

**General Description**

The MK-370 EXP Tile Saw is engineered as a tabletop or stand mounted wet tile saw. The saw includes a powerful 115V electric motor. The saw is capable of cutting tile up to twelve (12) inches in length. The saw can cut an object one and three quarters (1-3/4) inches thick in one pass.

**Motor Specifications**

Motor specifications for the MK-370 EXP are listed in Table 2 below.

Voltage	115V
Overall Amperage	5.3 A
Frequency	50/60Hz
RPM	5500 rpm
Horse Power	1/2 hp

Table 2

**Blade Capacity:**

The MK-370 EXP uses a 7 (7) inch (178mm) diameter, wet cutting continuous rim, MK Diamond blade with a five-eighths (5/8) inch (15.875 mm) arbor.

**Tile Types:**

The MK-370 EXP can cut a variety of tile types including Porcelain, Terra-cotta, Marble, Quarry and Slate, Ceramic or almost any other non-ferrous material.

**NOTE:** The MK-370 EXP is not designed to cut plastic or ferrous (metals) material.

# UNPACKING, TRANSPORT, STAND and ASSEMBLY

## UNPACKING

The MK-370 EXP is not designed to cut plastic or ferrous (metals) material.

**CAUTION** Use proper lifting techniques when lifting the MK-370 EXP. If not done, remove the MK-370 EXP, accessory box from the carton.

## CONTENTS

In your container, you will find

- |  |                                 |                         |
|--|---------------------------------|-------------------------|
| One (1) MK-370 cutting surface and water pan,    | One (1) splash guard wing nut,  | One (1) blade wrench    |
| One (1) MK-370 cutting head,                     | One (1) electric water pump,    | One (1) shaft wrench,   |
| One (1) 7-inch wet cutting continuous rim blade, | One (1) pump discharge fitting, | One (1) owners manual,  |
| One (1) splash guard,                            | One (1) cooling transfer tube   | One (1) pump manual and |
| One (1) splash guard washer,                     | One (1) Flow adjusting Clamp    | One (1) warranty card.  |

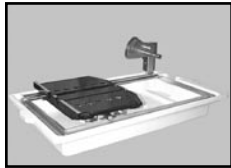

MK-370 EXP  
Cutting Surface



MK-370 EXP  
Cutting Head



Diamond Blade

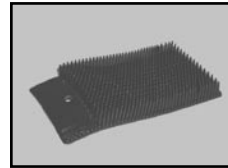

Splash Guard



Splash Guard  
Washer



Splash Guard  
Wing Nut



Electric  
Water Pump

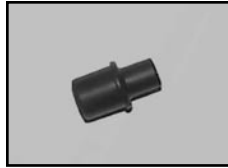

Pump  
Discharge Fitting



Cooling  
Transfer Tube



Flow  
Adjusting Clamp



Blade Nut  
Wrench



Inner Flange  
Wrench



Owners  
Manual



Pump  
Manual



Warranty  
Card

## TRANSPORT:

- CAUTION**
1. The MK-370 EXP weighs approximately forty-six (46) pounds; use care when transporting.
  2. Never transport the MK-370 EXP with water in the Water Pan.

The MK-370 EXP is designed with a rigid frame and removable Cutting Head making the saw easily transportable. To lift the saw, grasp the front and back of the frame at the lift points shown below.

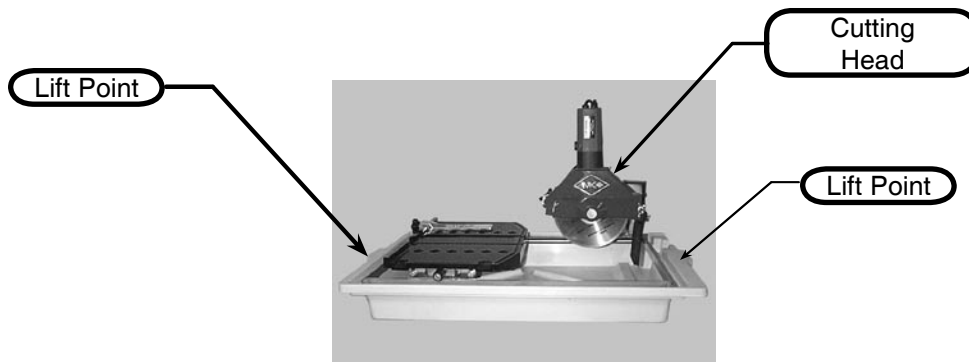

# UNPACKING, TRANSPORT, UNIVERSAL STAND and ASSEMBLY

## TILE SAW STAND

- ⚠ CAUTION**
1. The MK-370 EXP weighs approximately thirty (30) pounds; use care when transporting.
  2. Never transport the MK-370 EXP with water in the Water Pan.

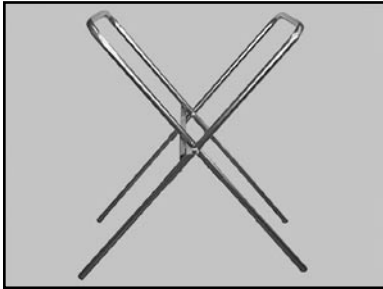

(A)  
Open the Stand  
and place on flat surface

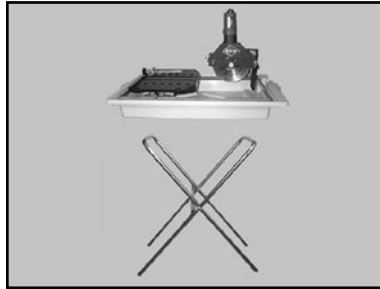

(B)  
Orient the Saw to the Stand

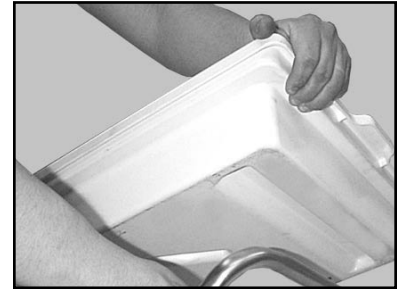

(C)  
Align the Stand supports to  
the depressions on the pan

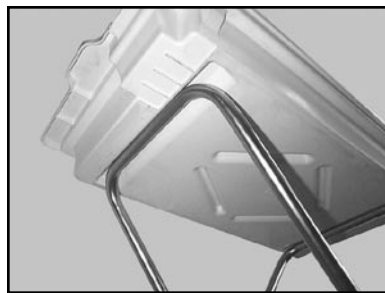

(D)  
Sit the Water Pan on top of  
the Stand Supports

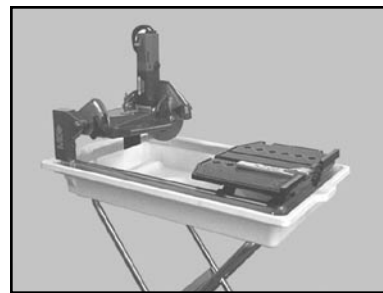

(E)  
Verify that the saw is stable in  
place

# UNPACKING, TRANSPORT, UNIVERSAL STAND and ASSEMBLY

## ASSEMBLY:

Follow the assembly instructions to prepare your MK-370 EXP for operation.

### 1. Cutting Head Installation:

NOTE: If the Cutting Head is installed, go to step 2.

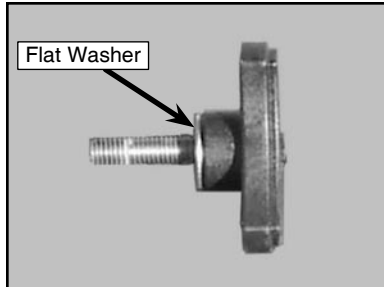

(A)

Place the Flat Washer onto the Height Adjusting Knob

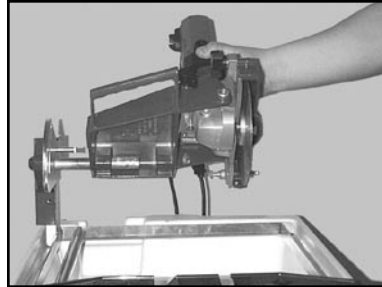

(B)

Align Cutting Head Pivot Hole to the Post, Pivot Shaft

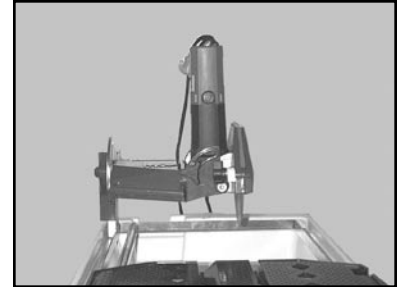

(C)

Verify the Cutting Head is completely installed and seated on the Post

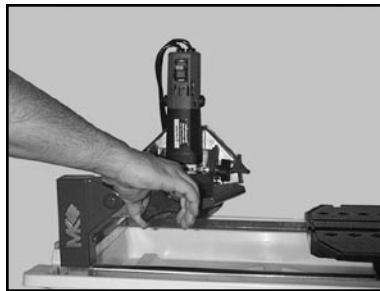

(D)

Install the Height Adjusting Knob through the Post into the Cutting Head and tighten the Knob

### 2. Diamond Blade Installation:

NOTE: When installing the Retaining Screw, do not "cross-thread" and DO NOT over tighten the screw.

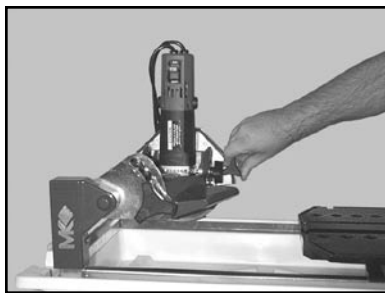

(A)

Loosen and remove the Blade Guard, Retaining Knob

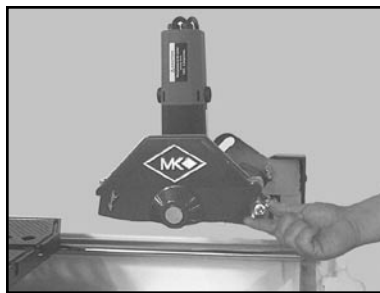

(B)

Loosen the Blade Guard, Retaining Wing nut

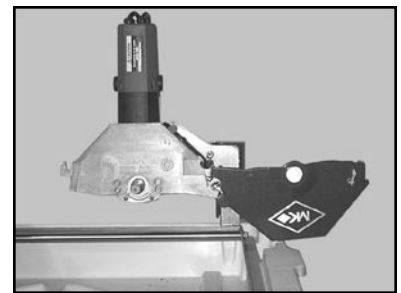

(C)

Open the Blade Guard

# UNPACKING, TRANSPORT, UNIVERSAL STAND and ASSEMBLY

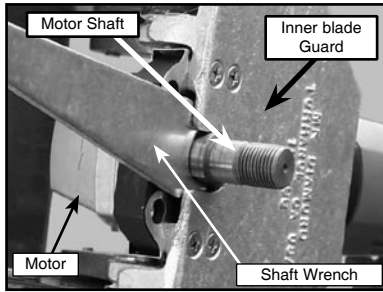

(D)  
Place the Shaft Wrench between the Inner Blade Guard and the Motor and onto the Motor Shaft

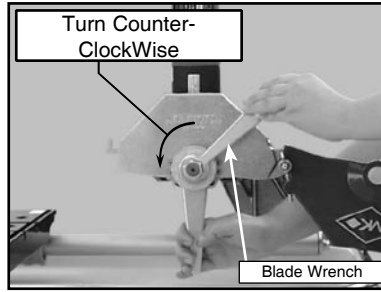

(E)  
Using the Blade and Shaft Wrenches, loosen and remove the Retaining Nut and Outer Flange

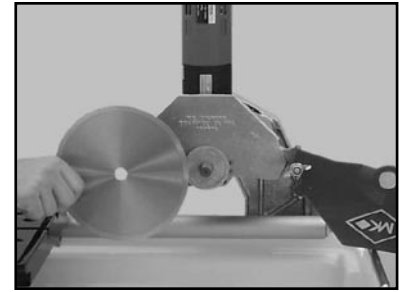

(F)  
Install Diamond Blade onto Blade Shaft

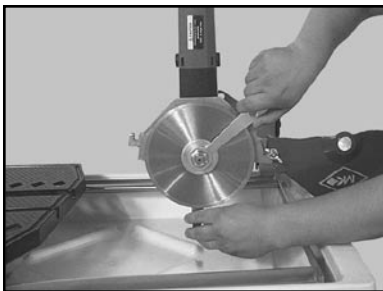

(G)  
Install the Retaining Nut and Outer Flange and then tighten using the Blade and Shaft Wrenches

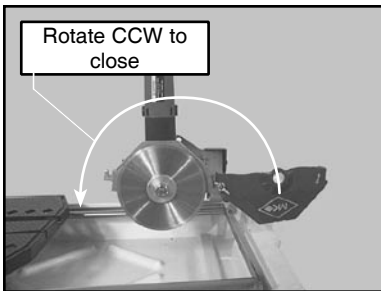

(H)  
Close the Blade Guard

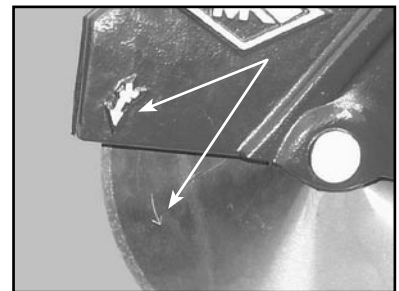

(I)  
Verify the Blade is seated on the Blade Shaft and direction of rotation is correct

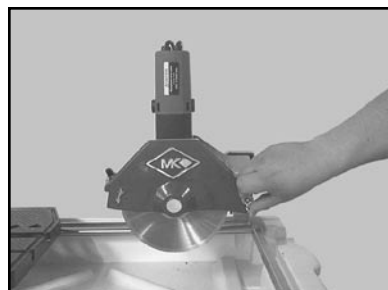

(J)  
Tighten the Blade Guard Retaining, Wing nut



(K)  
Tighten the Blade Guard, Retaining Knob

## UNPACKING, TRANSPORT, UNIVERSAL STAND and ASSEMBLY

### 3. Adjustable Cutting Guide Installation:

NOTE: The Adjustable Cutting Guide can be used on either side of the Diamond Blade.

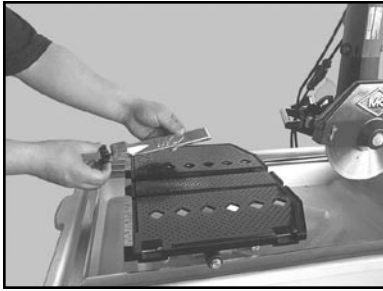

(A)  
Loosen Adjustable Cutting Guide retaining thumbscrew and place it over the Movable Cutting Table, Ruler/Stop

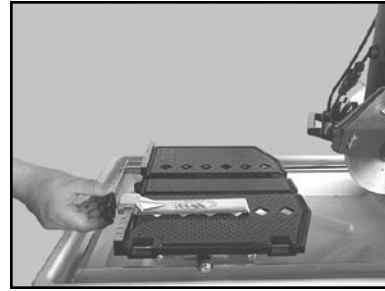

(B)  
Place the Adjustable Cutting Guide onto the Movable Cutting, Table Ruler/Stop and tighten the retaining thumbscrew

### 4. Splash Guard Installation

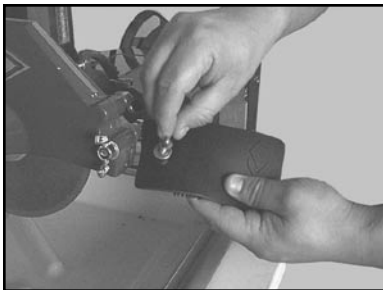

(A)  
Install the retaining thumbscrew through the washer and Splash Guard then align to the hole found on back of the Blade Guard

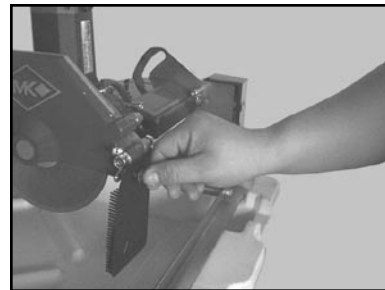

(B)  
Install the Splash Guard onto the Blade Guard

### 5. Water Pump Preparation:



(A)  
Install Water Pump Discharge Fitting

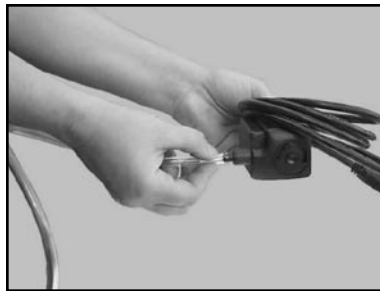

(B)  
Press one end of the Cooling Transfer Tube onto the Water Pump Discharge Fitting

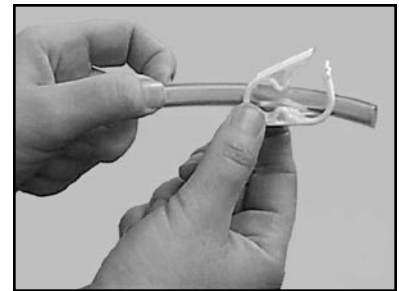

(C)  
Slide Cooling Flow Adjusting Clamp onto the Cooling Transfer Tube



# SETUP, ADJUSTMENT & OPERATION

## SETUP:

### 1. Pre-start Inspection:

Prior to beginning work, a pre-start inspection of the saw should be performed.



(A)  
Ensure the ON/OFF Switch is in the OFF position

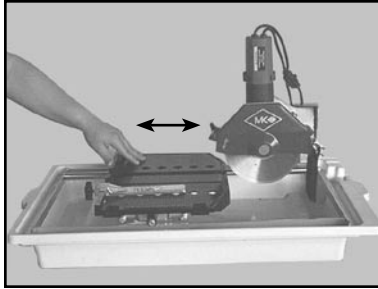

(B)  
Verify the Movable Cutting Table moves freely

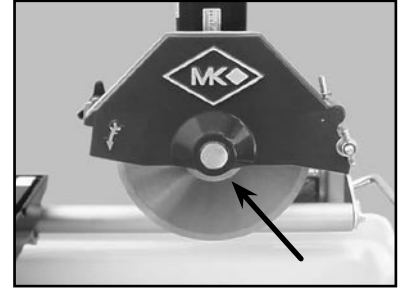

(C)  
Inspect the Diamond Blade for damage – verify the blade is correct for the type of material being cut



(D)  
Inspect the Pump Assembly for damage – ensure the cord is free of cracks or cuts

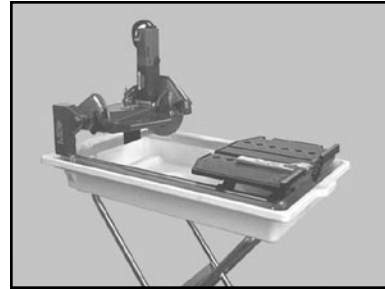

(E)  
Inspect the MK-370 EXP for damage – ensure the cord is free of cracks or cuts

### 2. Connecting the Water Pump:

#### **⚠ WARNING**



1. To prevent the possibility of electrical shock, the MK-370 EXP MUST be de-energized when connecting the Water Pump.
2. To prevent the possibility of electrical shock, use only MK Diamond qualified replacement parts.

NOTE: To prevent pump damage, the Water Pump must be disconnected if cutting with a Dry Blade.

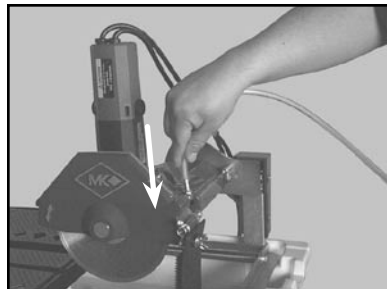

(A)  
Connect the Cooling Transfer Tube to the inlet connection of the Blade Guard

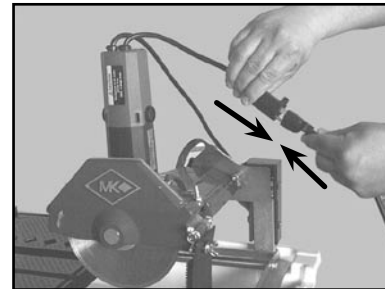

(B)  
Connect the Water Pump power cord to the connection found on the back of the motor

## SETUP, ADJUSTMENT & OPERATION

### 3. Water Pump Setup for Operation:

The Water Pump can be setup for operation in two ways: external Water Source or Re-circulation.

NOTE: If using a dry blade for operation, DO NOT connect the water pump.

#### I. Re-circulation:

NOTE: When using the re-circulation method, the water should be changed often for longer pump life

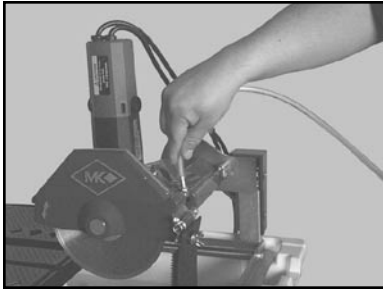

(A)

Ensure that Cooling Transfer Tube is connected

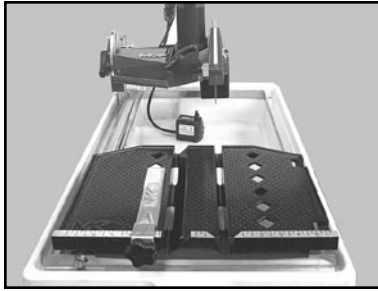

(B)

Place the Water Pump in the back of the Water Pan

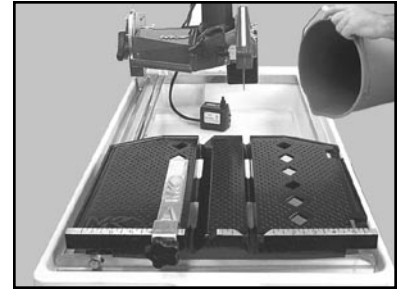

(C)

Fill the Water Pan until water completely covers the Water Pump suction

# SETUP, ADJUSTMENT & OPERATION

## 4. MK-370 EXP Setup for Operation



1. Before powering or starting, check for damage that could prevent this equipment from proper operation or performing its intended function. Check for binding and alignment of moving parts. Check for damaged, broken, or missing parts.
2. Verify the On/Off switch is in the OFF position.
3. Before connecting the MK-370 EXP to a power supply, be sure the voltage, cycle and phase of the job site power source meet the requirements of TABLE 3

VOLTAGE	115V
CYCLE	60Hz
PHASE	1-phase

TABLE 3

4. Use an approved Ground Fault Circuit Interrupter (GFCI)
5. Do not cover the motor vents as this could lead to motor overheating.

- NOTE:**
1. In order to avoid breaker tripping, a 20-amp circuit breaker should be used.
  2. If using an extension power cord, make sure the length and wire gauge correspond to the requirements listed in TABLE 1 on page 9. An extension power cord that is too small in wire gauge (diameter), or too long in length, will cause the motor to overheat and could cause premature failure.

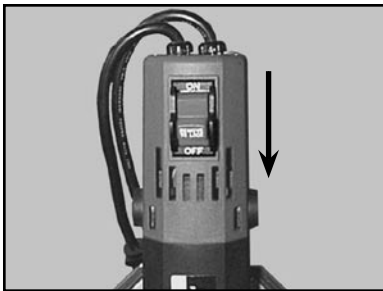

(A)

Ensure the ON/OFF Switch is in the OFF position

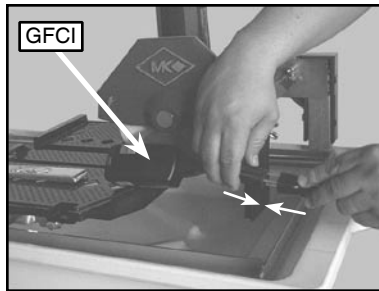

(B)

Plug MK-370 EXP into the GFCI



(C)

Plug the GFCI into the Power source

# SETUP, ADJUSTMENT & OPERATION

## ADJUSTMENT & OPERATION

### 1. Cutting Straight Edges:

**CAUTION** DO NOT FORCE THE TOOL. It will do the job better and safer at the rate for which it was designed.

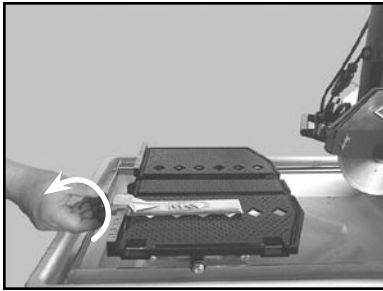

(A)  
Loosen the Adjustable Cutting Guide retaining thumbscrew

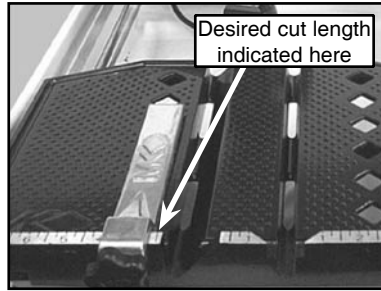

(B)  
Position the Adjustable Cutting Guide to desired cut length

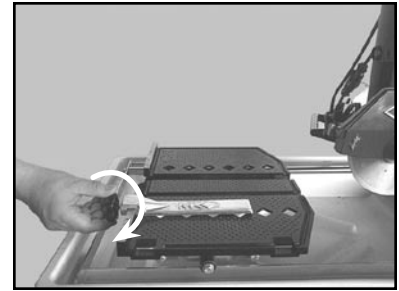

(C)  
Tighten the retaining thumbscrew

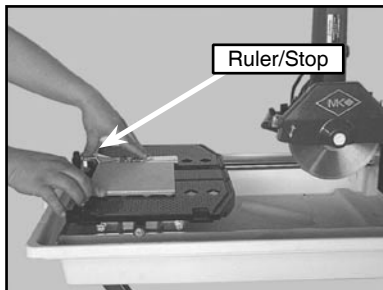

(D)  
Place the tile against the Ruler/Stop and Cutting Guide

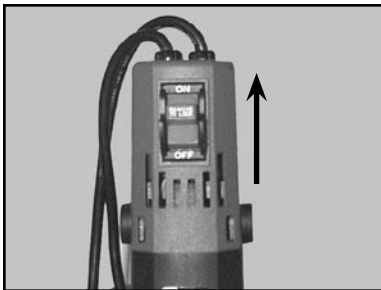

(E)  
Turn the motor ON

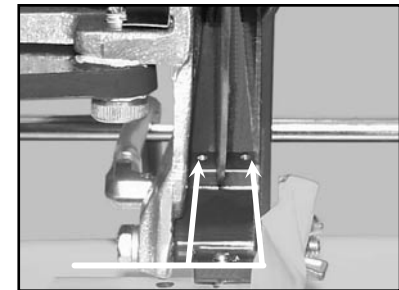

(F)  
Verify cooling flow on both sides of the blade

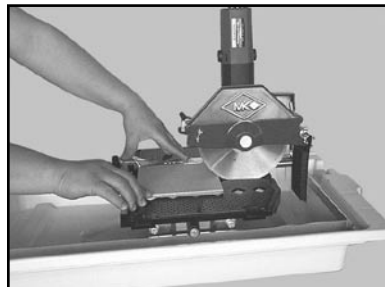

(G)  
Perform the cut



(H)  
Turn the motor OFF when work is complete

# SETUP, ADJUSTMENT & OPERATION

## 2. Cutting 45° Miters:

The MK-370 EXP is designed with an adjustable Cutting Head for precision 45° Miter Cuts.

**CAUTION** DO NOT FORCE THE TOOL. It will do the job better and safer at the rate for which it was designed.

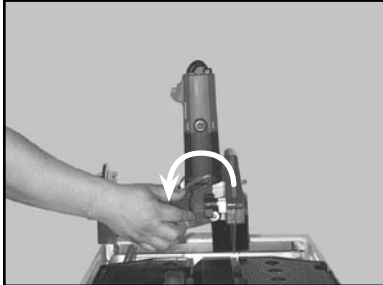

(A)  
Loosen the Cutting Head  
Pivot, Retaining Knob

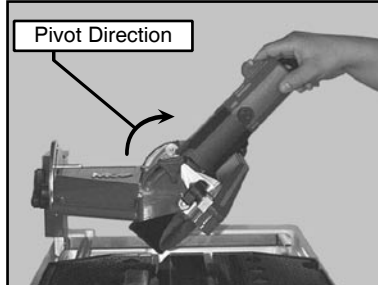

(B)  
Pivot the Cutting Head to the  
45° cutting position

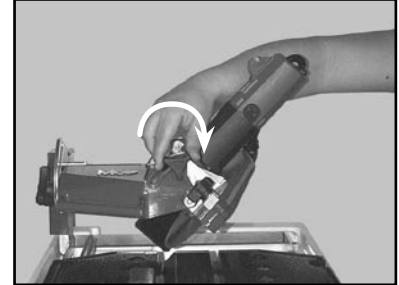

(C)  
Tighten the Cutting Head,  
Pivot Retaining Knob

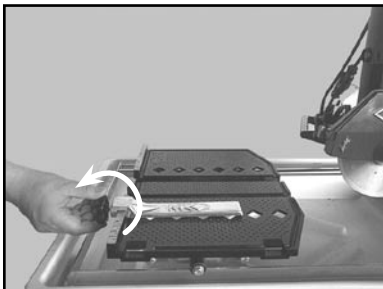

(D)  
Loosen the Adjustable Cutting  
Guide retaining thumbscrew

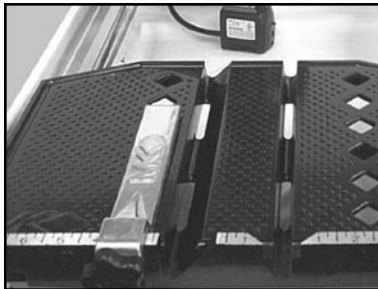

(E)  
Position the Adjustable  
Cutting Guide to  
desired cut length

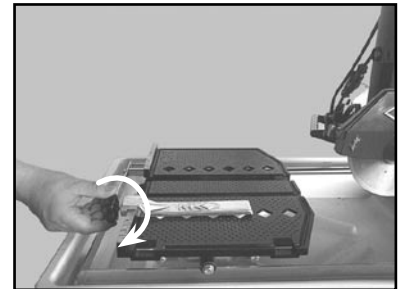

(F)  
Tighten the retaining  
thumbscrew

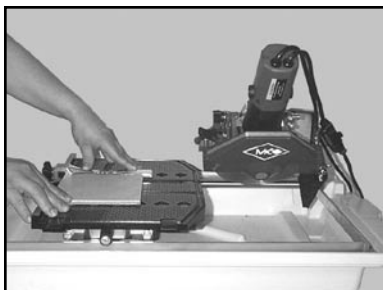

(G)  
Place the tile against the  
Ruler/Stop and Cutting Guide

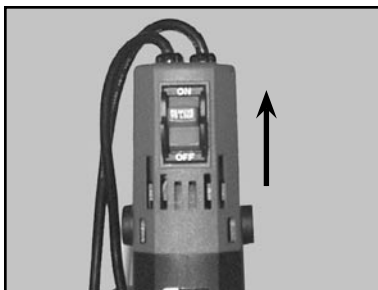

(H)  
Turn the motor ON

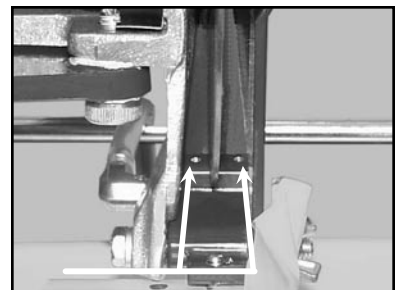

(I)  
Verify cooling flow on both  
sides of the blade

# SETUP, ADJUSTMENT & OPERATION

## Cutting 45° Miters (cont...)

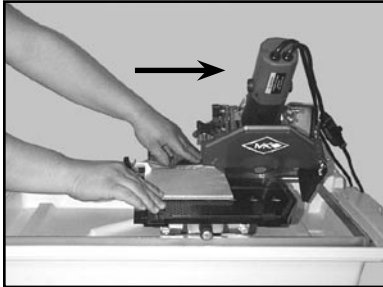

(J)  
Perform the cut

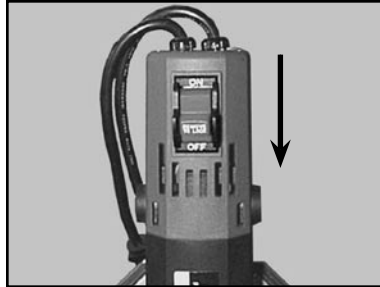

(K)  
Turn the motor OFF when  
work is complete

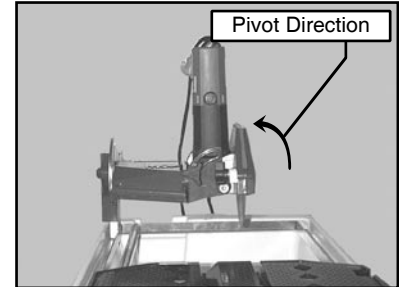

(L)  
Return the Cutting Head to  
the upright position when  
complete

# SETUP, ADJUSTMENT & OPERATION

## 3. Diagonal Cutting:

NOTE: To cut diagonal, the Dual 45° Flat Angle Guide (MK Diamond Part No. 134557-MK) should be used.

**CAUTION** DO NOT FORCE THE TOOL. It will do the job better and safer at the rate for which it was designed.

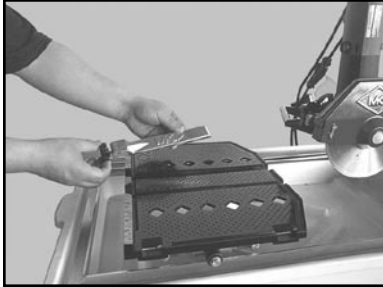

(A)  
Remove the Adjustable  
Cutting Guide

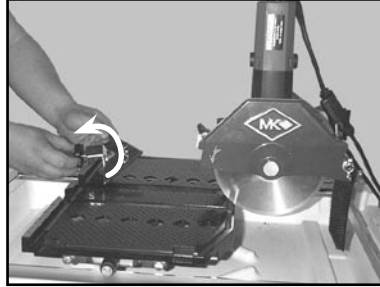

(B)  
Place the Dual 45° Flat Angle  
Guide on the Ruler/Stop

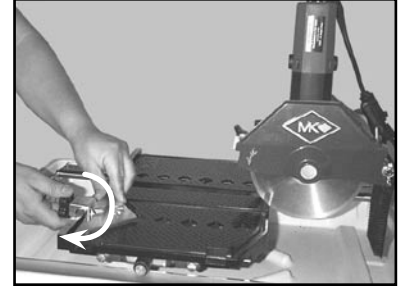

(C)  
Position the Dual 45° Flat  
Angle Guide and tighten the  
retaining knob

NOTE: If Cutting the tile in two equal halves, align the tile in the V-notch of the Movable Cutting Table Ruler/Stop.

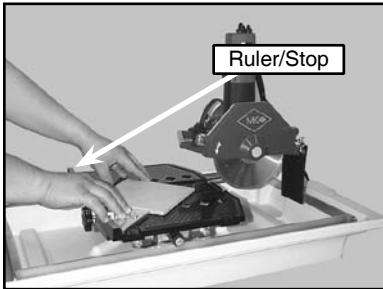

(D)  
Position the tile against the  
Dual 45° Flat Angle Guide and  
the Ruler/Stop

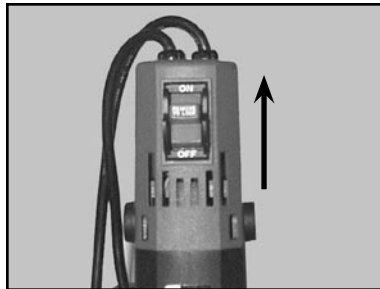

(E)  
Turn the motor ON

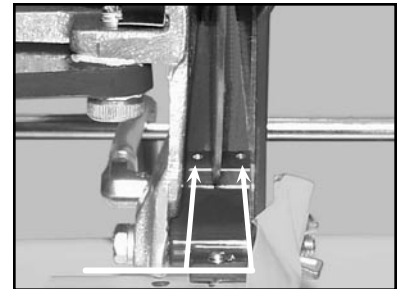

(F)  
Verify cooling flow on both  
sides of the blade

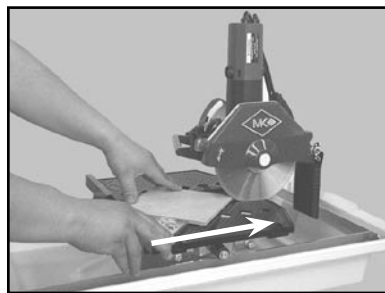

(G)  
Perform the cut

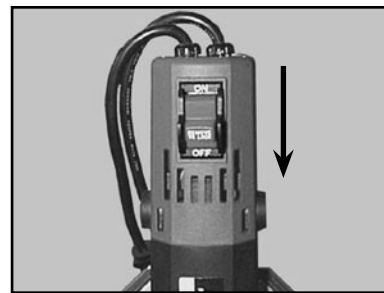

(H)  
Turn the motor OFF when  
work is complete

# SETUP, ADJUSTMENT & OPERATION

## 4. Off-angle Cutting:

NOTE: Use a Protractor (MK Part No. 134569-MK) to cut angles other than 45° angles. (not included)

**CAUTION** DO NOT FORCE THE TOOL. It will do the job better and safer at the rate for which it was designed.

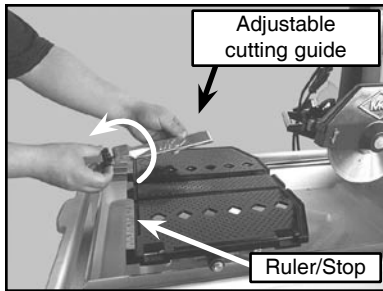

(A)  
Remove the Adjustable Cutting Guide

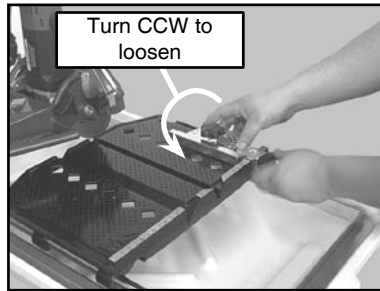

(B)  
Place the Protractor on the Ruler/Stop

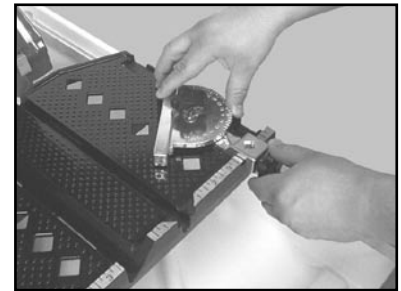

(C)  
Set the desired angle on the Protractor Gage

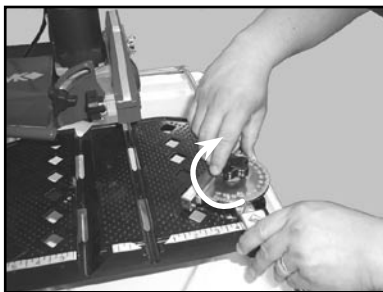

(D)  
Tighten the Protractor Gage retaining knob

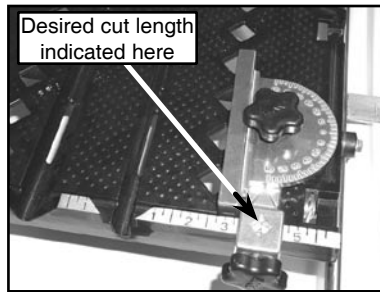

(E)  
Position the Protractor Cutting Guide to the desired length

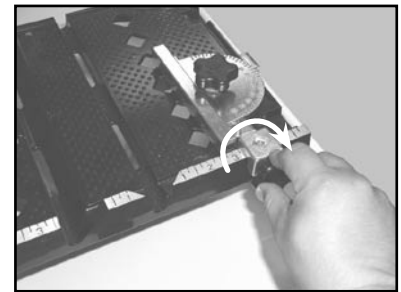

(F)  
Tighten the retaining knob

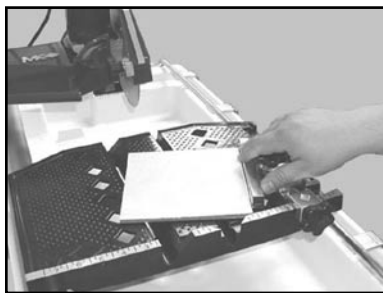

(G)  
Position the tile against the Protractor and the Ruler/Stop

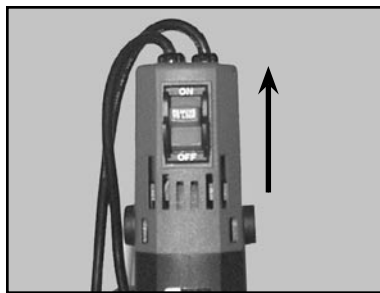

(H)  
Turn the motor ON

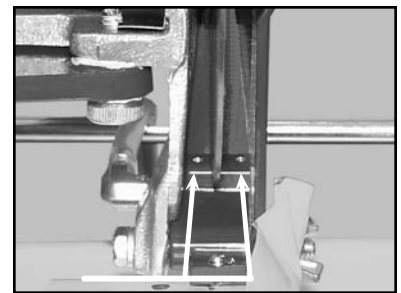

(I)  
Verify cooling flow on both sides of the blade



(G)  
Perform the cut



(H)  
Turn the motor OFF when work is complete



# SETUP, ADJUSTMENT & OPERATION

## CLEANUP

NOTES: Dispose of wastewater in accordance with applicable Federal, State and Local laws.

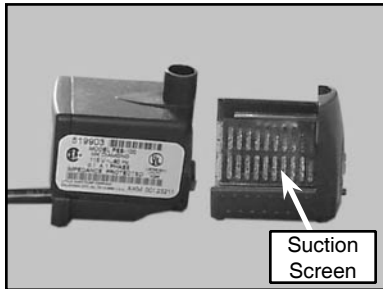

(A)  
Remove the pump Suction Screen and clean the Water Pump of all debris

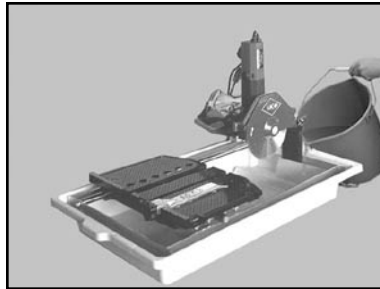

(B)  
Fill the Water Pan with clean water

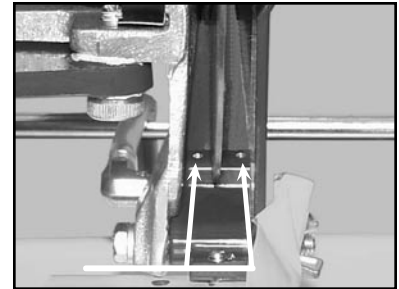

(C)  
Run the MK-370 EXP until clear water is seen at the blade Cooling Flow Points (Approx. 1 minute) retaining thumbscrew

**CAUTION** Ensure the saw is disconnected before completing the remainder of the cleanup process.

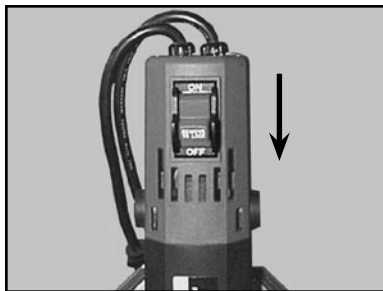

(D)  
Ensure the ON/OFF Switch is in the OFF position

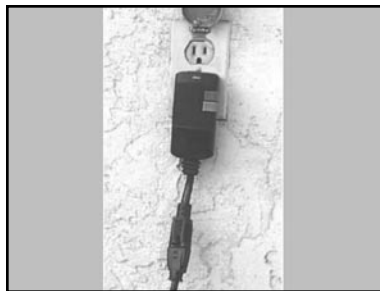

(E)  
Unplug the GFCI from the Power source

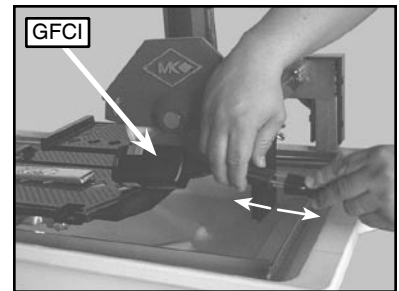

(F)  
Unplug MK-370 EXP from the GFCI



(G)  
Remove the Cutting Assembly from the Water Pan



(H)  
Dispose the contents of the Water Pan



(I)  
Clean the MK-370 with soap and clean water

## SETUP, ADJUSTMENT & OPERATION

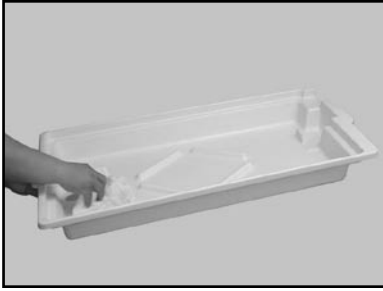

(I)  
Clean the Water Pan



(J)  
Clean the Adjustable Cutting  
Guide, Guide Bar

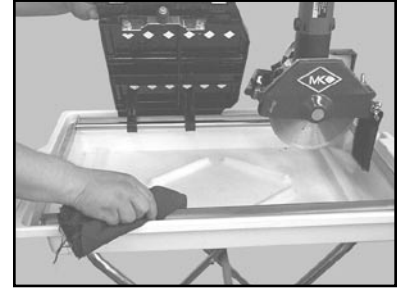

(K)  
Clean the Roller Wheel Guide  
Rail

**CAUTION** Ensure water is not forced into the motor casing when cleaning.

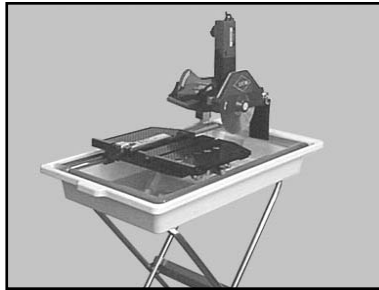

(L)  
Clean the remainder of the  
MK-370 EXP

# MAINTENANCE AND TROUBLESHOOTING

## MAINTENANCE

### 1. Maintenance Following Use:

To extend the life of the MK-370 EXP, the following procedure should be performed after each use. Lubricate all points listed below with light oils such as, 3 in 1, WD-40, etc.



(A)  
Ensure the ON/OFF Switch is in the OFF position

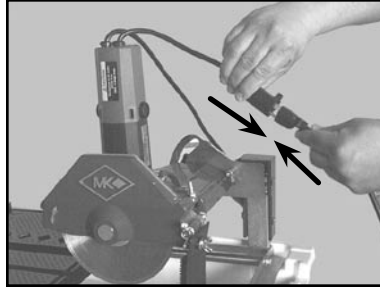

(B)  
Unplug MK-370 EXP

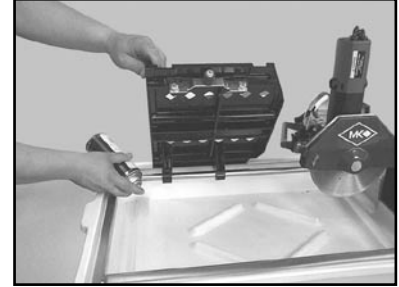

(C)  
Lubricate the Guide Bar

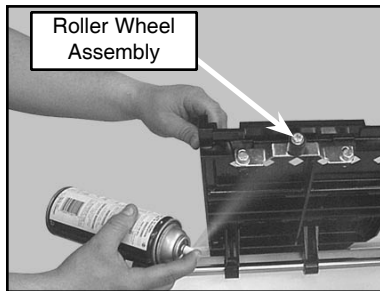

(D)  
Lubricate the Roller Wheel Assembly

### 2. Monthly Maintenance:

The following maintenance should be performed Monthly.

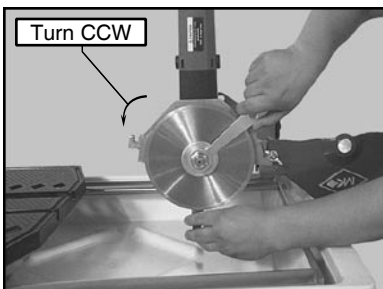

(A)  
Remove the Diamond Blade, Outer Flange and Retaining Nut

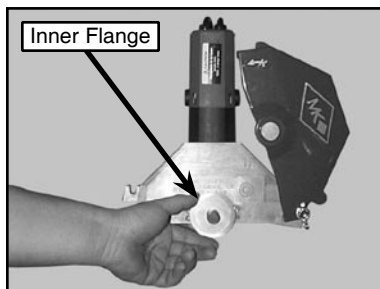

(B)  
Remove the Inner Flange

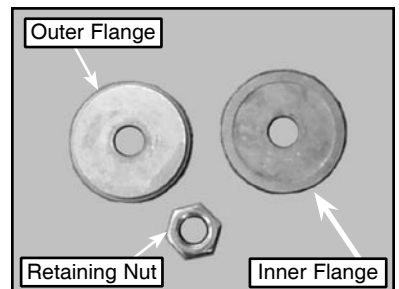

(C)  
Clean and Lubricate the Inner and Outer Flanges and the Retaining Nut

# MAINTENANCE AND TROUBLESHOOTING

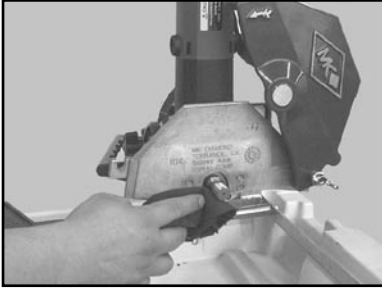

(D)  
Clean around Motor Shaft

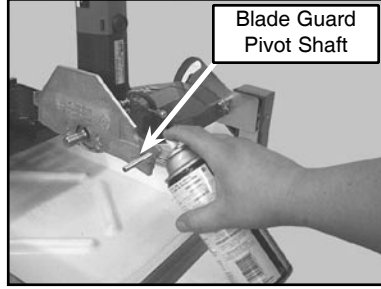

(E)  
Remove the Blade Guard then clean and Lubricate the Blade Guard Pivot Shaft

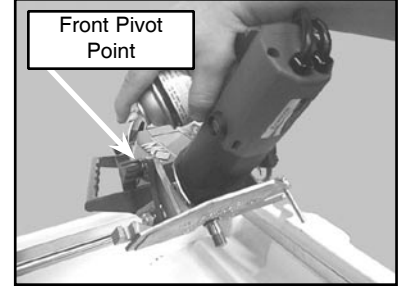

(F)  
Lubricate the front Cutting Head Pivot Point

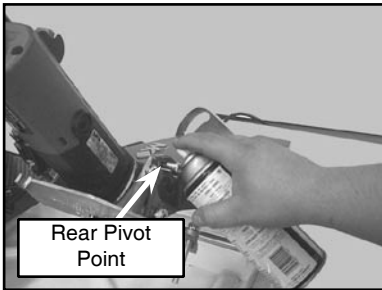

(G)  
Lubricate the rear Cutting Head Pivot Point

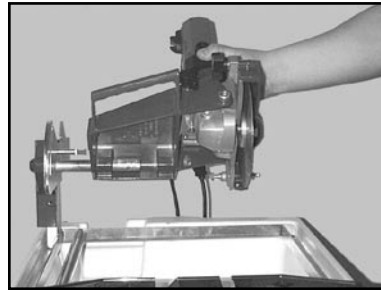

(H)  
Remove the Cutting Head

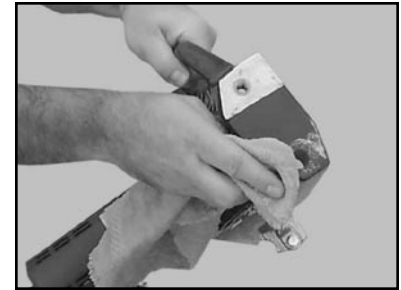

(I)  
Clean the Cutting Head Pivot Holes



(J)  
Lubricate the Cutting Head Pivot Holes

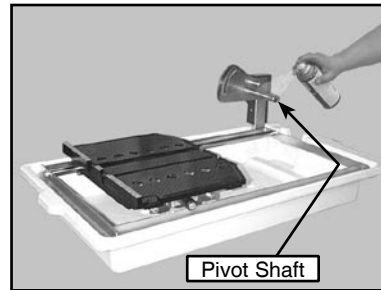

(K)  
Lubricate the Cutting Head Pivot Shaft

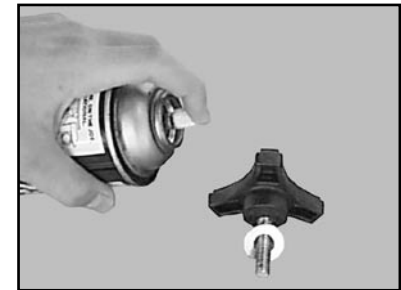

(L)  
Lubricate the Cutting Head Adjustment Knob

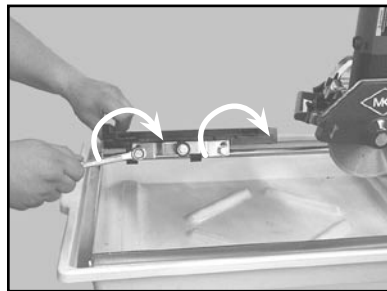

(M)  
Verify the Cutting Table Roller Wheel Assembly is tight

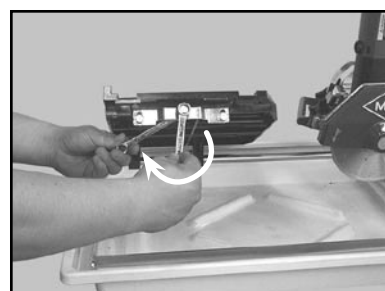

(N)  
Verify that the Roller Wheel is tight

## 3. Flow Adjustment:

NOTE: If flow to the diamond blade requires adjustment, perform the following actions.

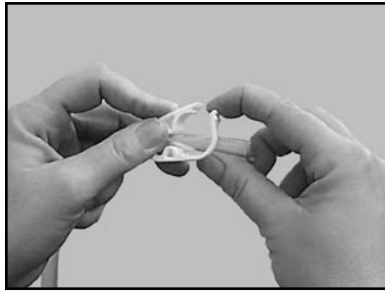

(A)  
Increase cooling flow by  
releasing the Flow Adjusting  
Clamp

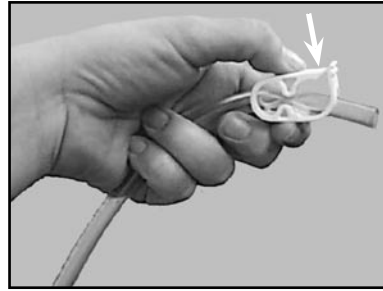

(B)  
Reduce cooling flow by  
Pressing down on the Flow  
Adjusting Clamp

# MAINTENANCE AND TROUBLESHOOTING

## 4. Blade Dressing

Like most cutting instruments, a diamond blade performs best when it is dressed. Over time and use, diamonds on the outer edge of the blade will become smoothed or “glazed” over.

This will reduce grinding efficiency and may cause the blade to “wander” or bend giving the illusion of an alignment problem. When this occurs, the blade will need to be dressed.

The diamond blade can be dressed using the MK Dressing Stick (part number 152792) and by following the steps below.

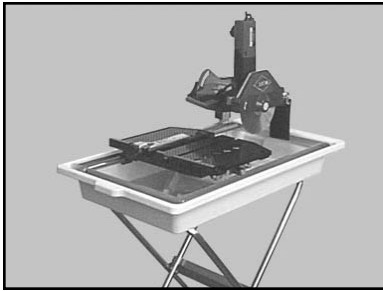

(A)  
Setup the MK-370 EXP for operation (See Setup, Adjustment and Operation)

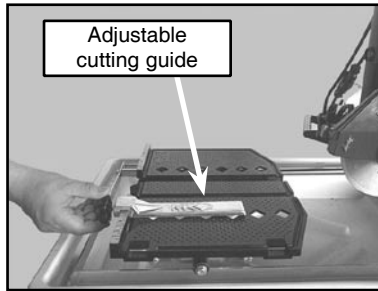

(B)  
Set the Adjustable Cutting Guide to cut a 1/16-strip

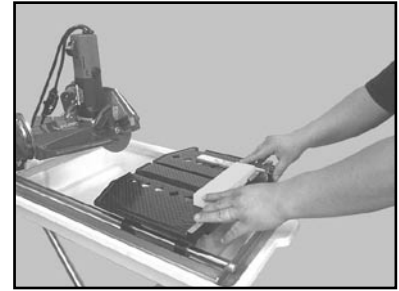

(C)  
Position the Dressing Stick

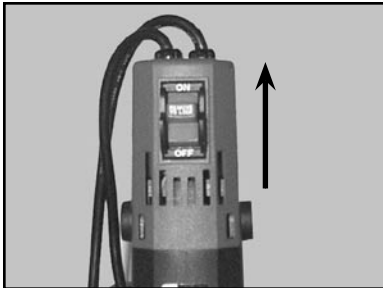

(D)  
Turn the motor ON

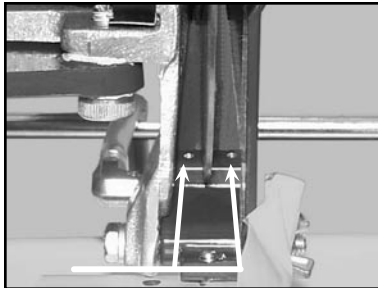

(E)  
Verify cooling flow on both sides of the blade

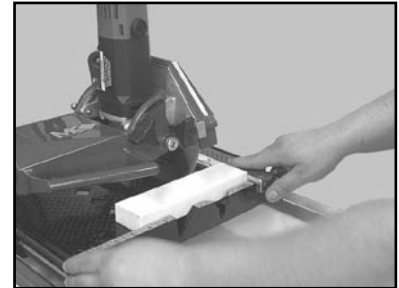

(F)  
Cut the Dressing Stick 7 or 8 times to dress the Blade



(G)  
Ensure the ON/OFF Switch is in the OFF position

# MAINTENANCE AND TROUBLESHOOTING

## 5. Diamond Blade Change-out:

NOTE: When installing the Retaining Nut, do not “cross-thread” and DO NOT over tighten the screw.

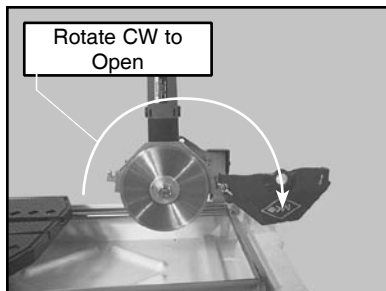

(A)  
Open the Outer Blade

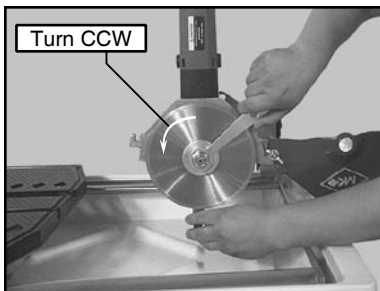

(B)  
Remove Retaining Nut and  
Outer Flange

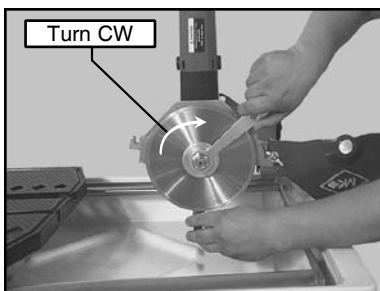
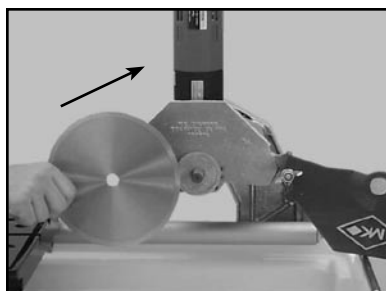
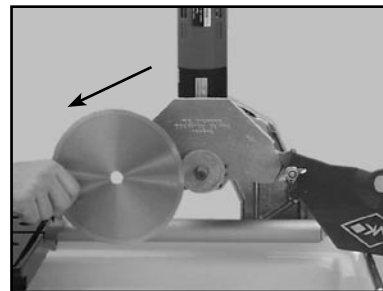

(E)  
Install the Retaining Nut and  
Outer Flange and then tighten  
using the Blade and Shaft  
Wrenches

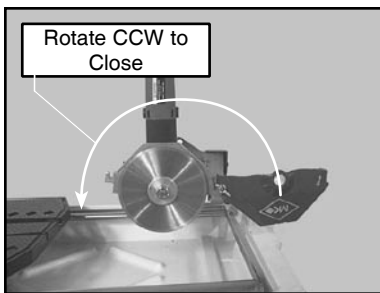
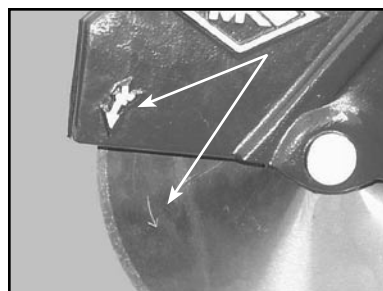

(G)  
Close the Outer Blade

# MAINTENANCE AND TROUBLESHOOTING

## ALIGNMENT:

The Movable Cutting Table of the MK-770 is pre-aligned in the factory. It may become misaligned with the Cutting Head of the Tile Saw over time. Should misalignment occur, perform the following steps to realign it.

NOTE: If alignment problems are the result of a warped blade, a bent frame or bent support arm, or, if alignment is off by more than 1/8-inch, contact the MK Diamond Service Center – (800) 474-5594

## TOOLS NEEDED:

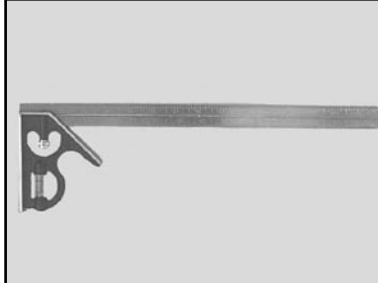

Combination Square  
12-inch or Greater



1/2-inch Wrench



1/4-inch Wrench

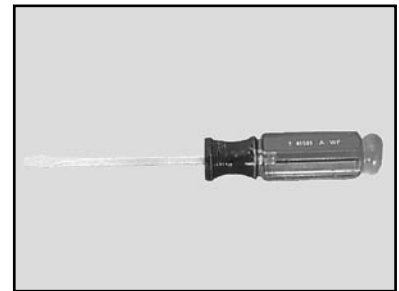

Flat Head Screwdriver

## PREPARATION:

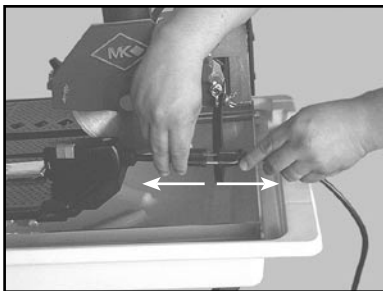

(A)  
Remove Tile Saw  
from Power Source

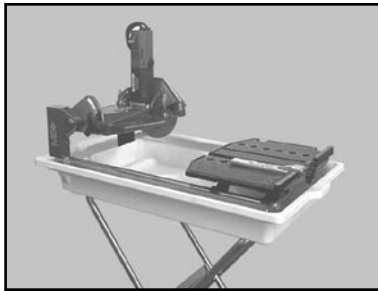

(B)  
Inspect Tile Saw  
for damage

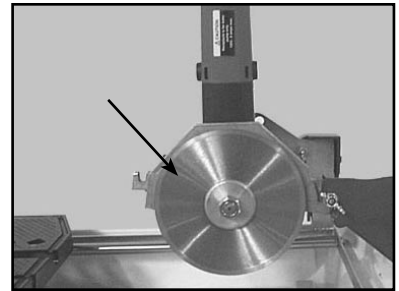

(C)  
Inspect Diamond Blade  
for damage



# MAINTENANCE AND TROUBLESHOOTING

## MOVABLE CUTTING TABLE ALIGNMENT VERIFICATION:

This will verify the Movable Cutting Table is aligned to the frame of the saw.

NOTES: If the blade is misaligned following alignment verification, attempt to align using Alignment Screw, 90° Verification. The Diamond Blade must be removed and reinstalled when removing the Blade Guard.

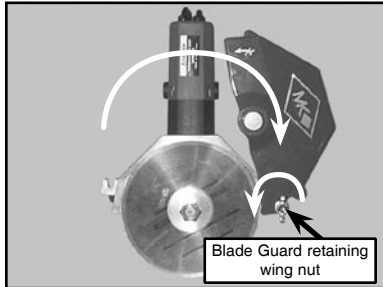

(A)  
Remove Blade Guard

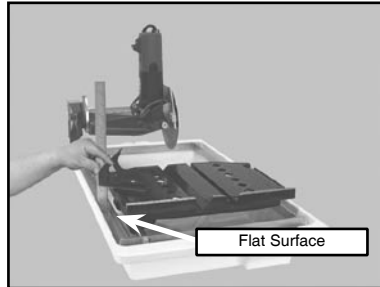

(B)  
Place Square on guide bar  
side of cutting table

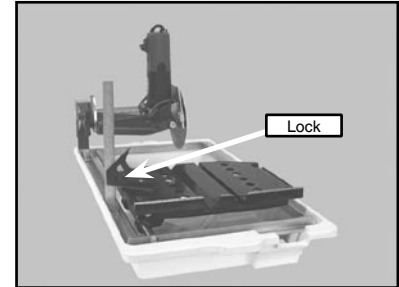

(C)  
Lock in position

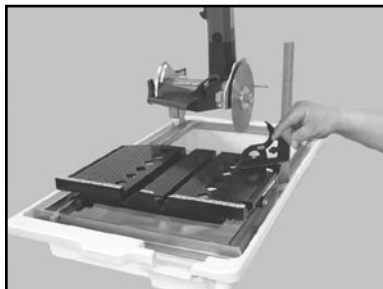

(D)  
Move Square to wheel  
assembly side of the cutting  
table

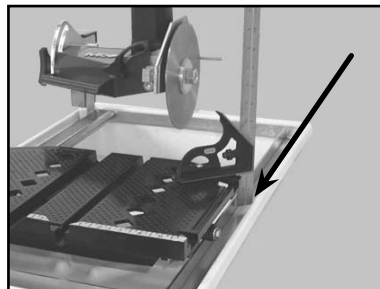

(E)  
Verify Wheel Assembly side of  
Movable Cutting Table height  
is same as Guide Bar side

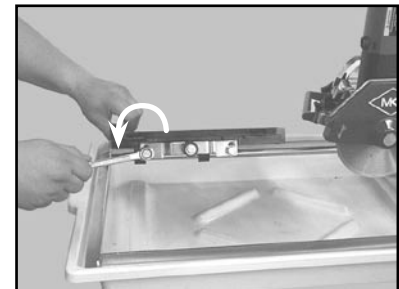

(F)  
If Gap exists, loosen Movable  
Cutting Table Wheel  
Assembly

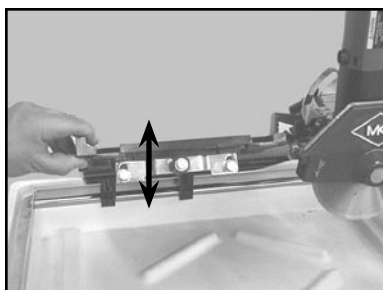

(G)  
Move Wheel Assembly up or  
down to Square the Movable  
Cutting Table

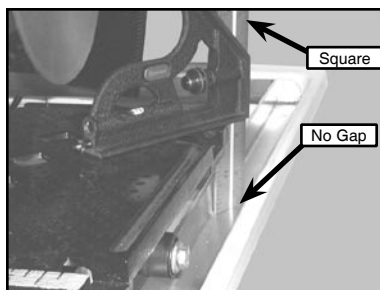

(H)  
Check that there is no gap  
between the Square and the  
wheel assembly side of frame

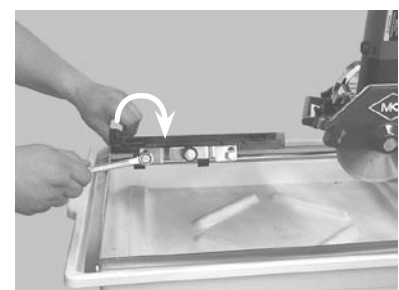

(I)  
Tighten Movable Cutting  
Table Wheel Assembly

# MAINTENANCE AND TROUBLESHOOTING

## Alignment Screw, 90° Verification:

90°-alignment verification will ensure that the blade will cut the tile straight up and down and not at an angle.

NOTES: If the blade is misaligned following this alignment procedure, return the saw to MK Diamond for repair. The Diamond Blade must be removed and reinstalled when removing the Blade Guard.

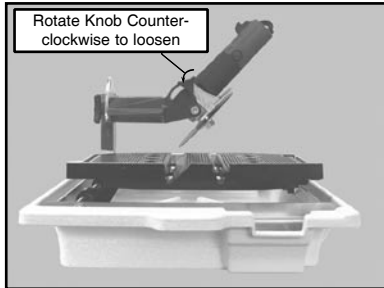

(A)  
Position the Cutting Head to the 45° Cutting Angle

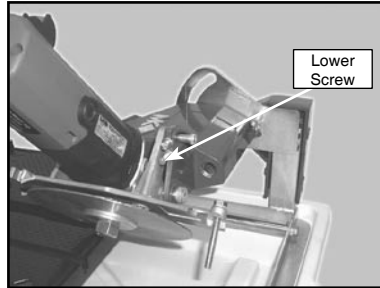

(B)  
Locate the 90° Adjustment Screw

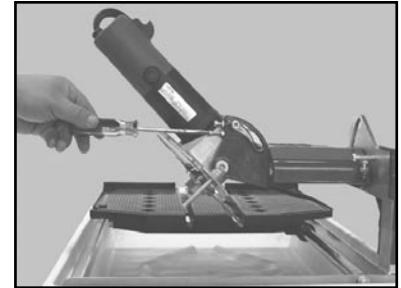

(C)  
Rotate 90° Adjustment Screw clockwise or counter-clockwise to realign Cutting Head

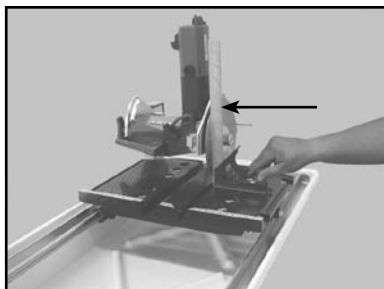

(D)  
Position the Square on Movable Cutting Table against the Diamond Blade

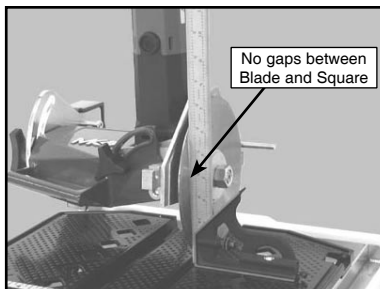

(E)  
Verify the Diamond Blade is Square to the Movable Cutting Table

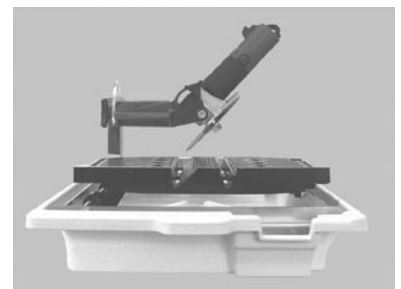

(F)  
Repeat Steps A to E as necessary to align the Cutting Head

## Horizontal Rough Alignment:

The Horizontal alignment will ensure that straight cuts (or Rip Cuts) are made.

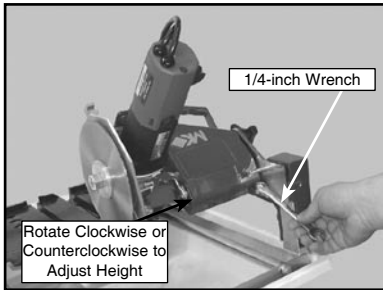

(A)  
Position Cutting Head to normal Cut Depth

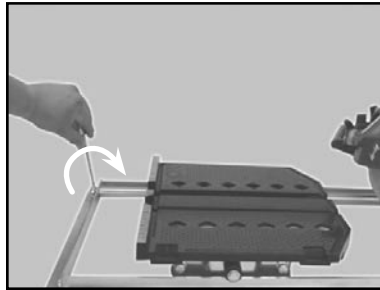

(B)  
Loosen front and rear Guide Bar Retaining Bolts

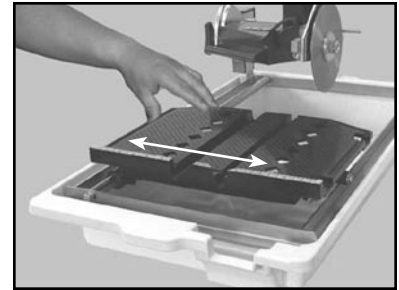

(C)  
Move Guide Rail and Table until the Blade is centered in Cutting Groove

## Horizontal Final Alignment:

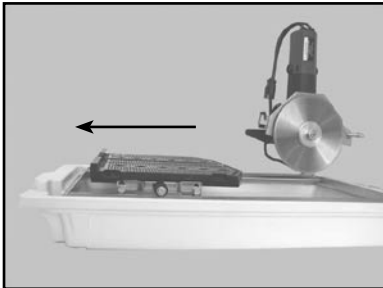

(A)  
Pull Movable Cutting Table to front of Tile Saw

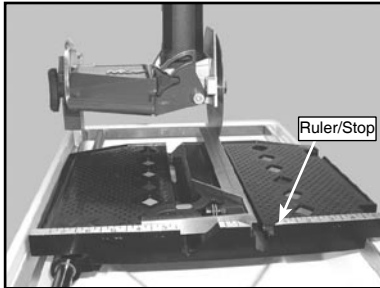

(B)  
Position Square flat on Movable Cutting Table against Ruler/Stop

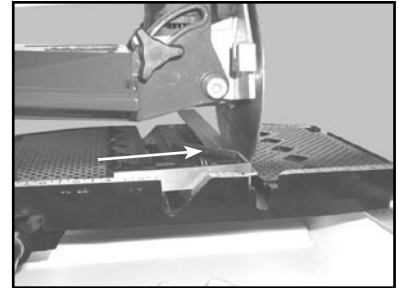

(C)  
Position front of Square against Blade

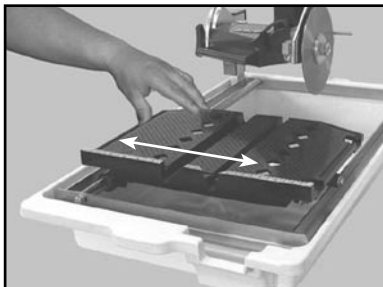

(D)  
Move Guide Bar and table until Square rests evenly across Blade

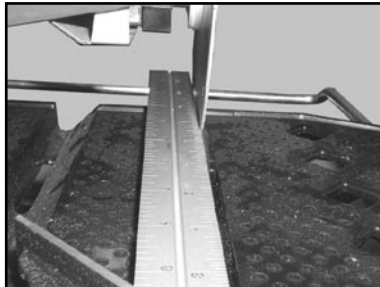

(E)  
Position end of Square against Blade

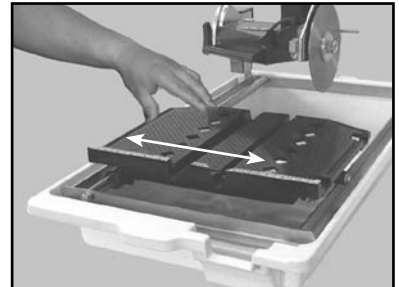

(F)  
Move Guide Bar and table until Square rests evenly across Blade

## Horizontal Alignment Verification:

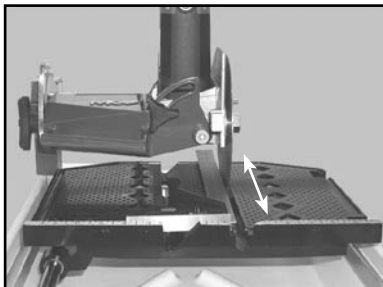

(A)  
Move the Cutting Table back and forth to verify Blade is even across all points of Square

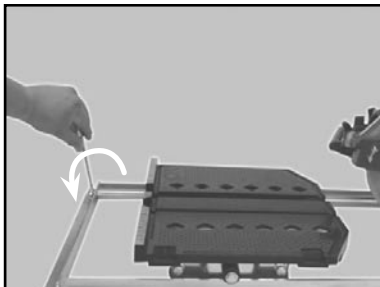

(B)  
Tighten Guide Bar Retaining Bolts

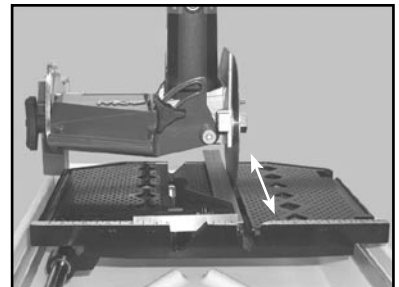

(C)  
Move the Cutting Table back and forth to re-verify Blade is even across all points of Square

# MAINTENANCE AND TROUBLESHOOTING

## 45° Alignment Verification:

The 45° Alignment Verification is done to ensure the blade will cut tile at a 45° angle.

NOTES: If the blade is misaligned following this alignment procedure, return the saw to MK Diamond for repair. The Diamond Blade must be removed and reinstalled when removing the Blade Guard.

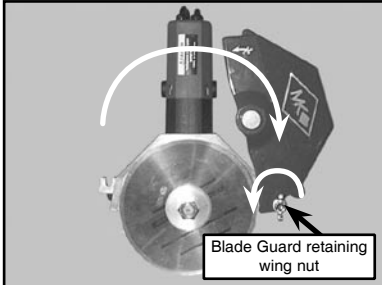

(A)  
Remove Blade Guard  
(If not done Previously)

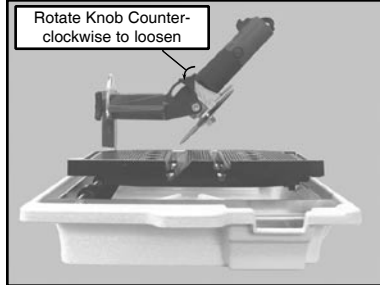

(B)  
Position the Cutting Head to the 45° Cutting Angle

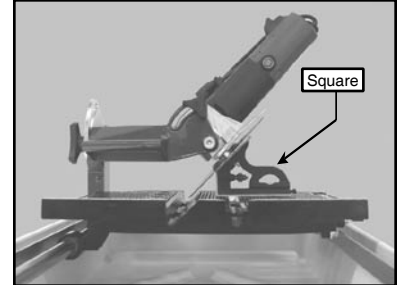

(C)  
Place Square on the Movable Cutting Table and position the Square against the Blade

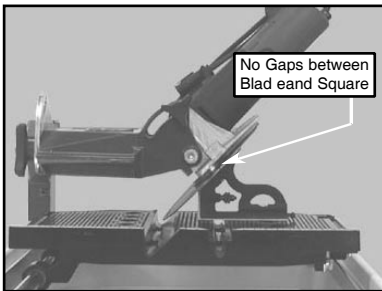

(D)  
Verify Blade is even across all points of Square

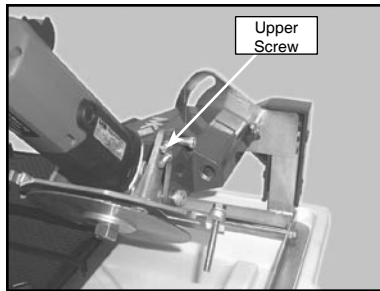

(E)  
To Adjust 45° Cutting Angle, locate the 45° Adjustment Screw

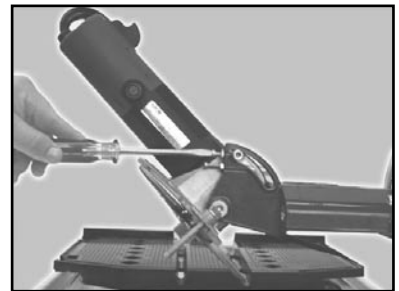

(F)  
Rotate 45° Adjustment Screw clockwise or counter-clockwise to realign 45° Cutting Angle

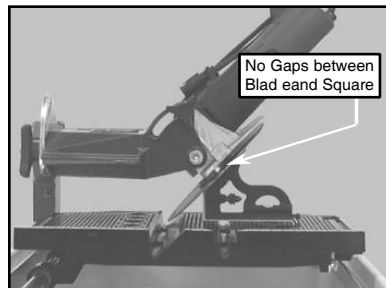

(G)  
Verify Blade is now even across all points of Square

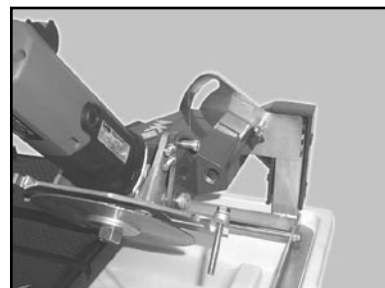

(H)  
Repeat steps A to G until Blade is even across all points of Square

## TROUBLESHOOTING

### 1. Blade will not cut properly:

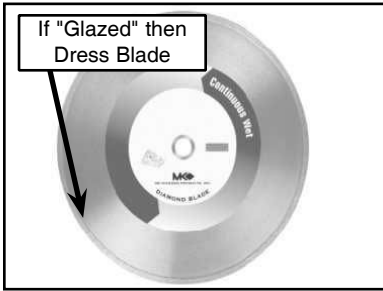

(A)  
Check for Smoothness or "Glazing" (Dress blade if needed)

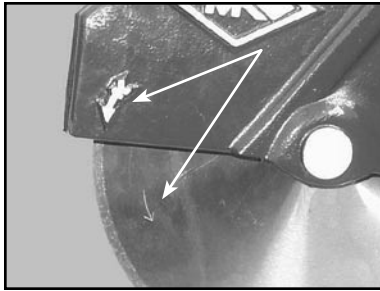

(B)  
Check for proper rotation

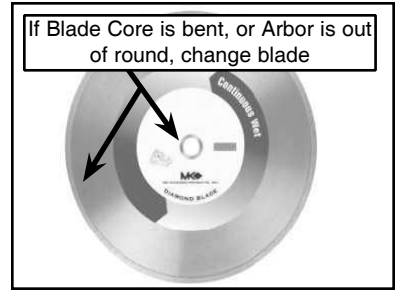

(C)  
Ensure the Blade Core is not bent and Arbor is not out of round



(D)  
Verify the blade is correct for the material being used



(E)  
Return to MK Diamond for Repair

### 2. Movable Cutting Table Does Not Move Correctly:



(A)  
Check that the Guide Bar is clean – clean if dirty

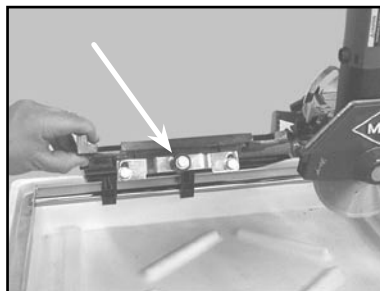

(B)  
Check the Movable Cutting Table Roller Wheel for wear replace if necessary



(C)  
Return to MK Diamond for Repair

# MAINTENANCE AND TROUBLESHOOTING

## 3. Cooling Flow:

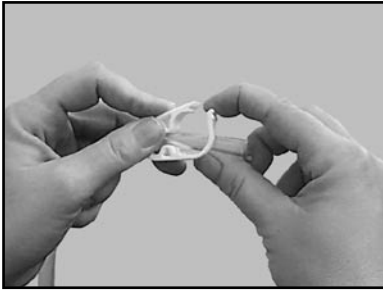

(A)  
Check cooling flow Adjusting  
Clamp open

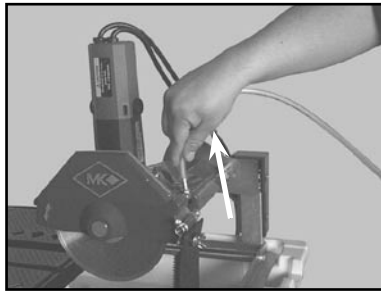

(B)  
Remove the Cooling Transfer  
Tube from the Blade Guard  
inlet

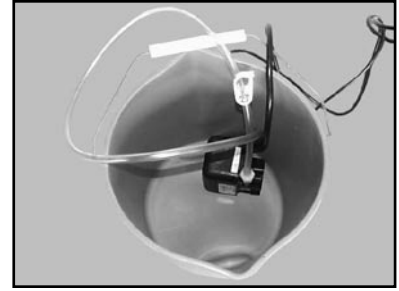

(C)  
Place Pump into a bucket of  
water and check flow

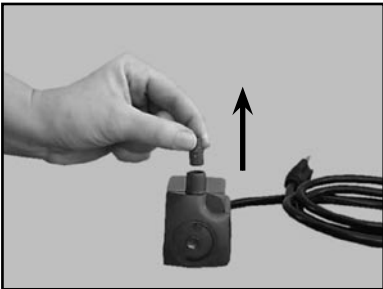

(D)  
Remove the Cooling Transfer  
Tube and check flow

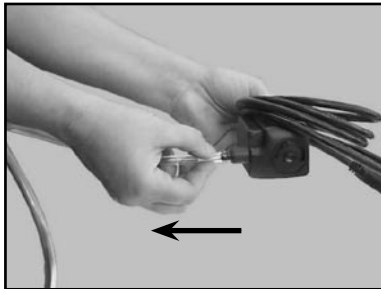

(E)  
Remove the Pump Discharge  
Fitting and check

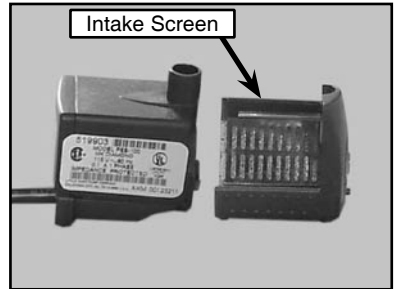

(F)  
Remove the Pump Intake  
Screen and check for debris



(I)  
Remove the Blade Guard  
Intake Fitting



(J)  
Clean the Blade Guard Intake  
Fitting

# MAINTENANCE AND TROUBLESHOOTING

**NOTE:** “Rodding” cooling channels is performed by inserting a small wire rod through the cooling inlet on top of the Blade Guard and directing the rod out through each of the cooling flow tubes located on the underside of the Blade Guard. The cooling channels should be “rodded” until all ports are free of foreign debris.

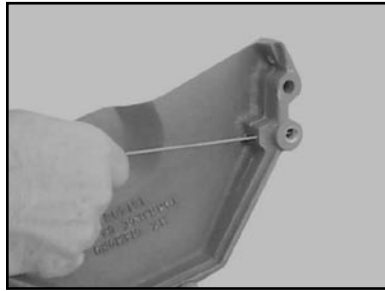

(K)  
Rod Cooling Channels and  
recheck flow



(L)  
Return to MK Diamond  
for Repair

## 4. Blade Stops Turning

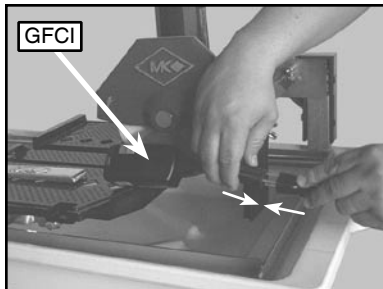

(A)  
Verify all plugs are fully  
installed

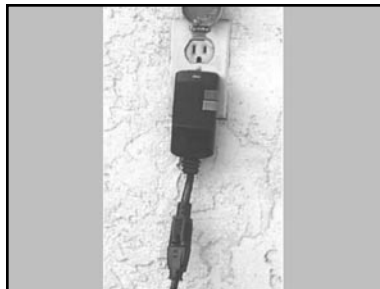

(B)  
Check to see if the Ground  
Fault Circuit Interrupter (GFCI)  
is tripped

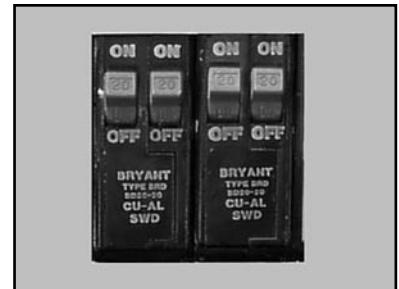

(C)  
Verify circuit breaker at least  
20 amps – if not, move to  
20-amp circuit

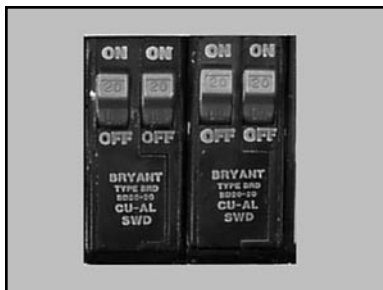

(D)  
Verify circuit breaker not  
tripped. If tripped, reset once

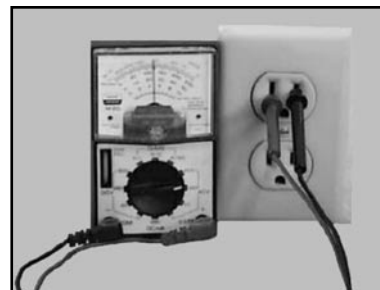

(E)  
Check power source voltage  
is 115V – if not 115v, move to  
another circuit



(L)  
Return to MK Diamond  
for Repair

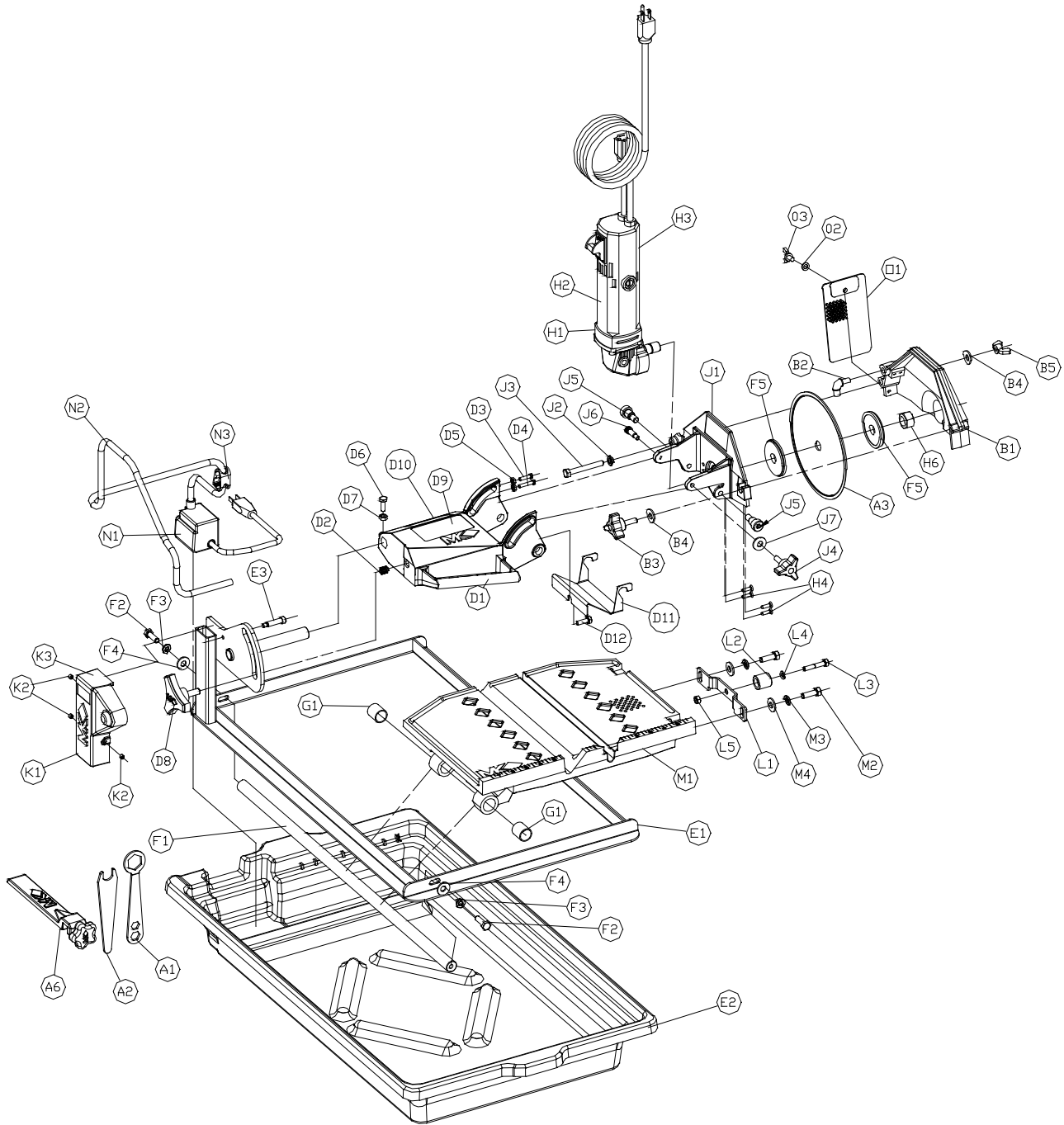

**EXPLODED VIEW**



## MK-370 EXP PARTS LIST

### PARTS LIST:

Item	Description	Qty	Part #
A	Accessories	1	n/a
A1	Wrench, Blade Nut, 15/16 Boxed End	1	134684
A2	Wrench, Blade Shaft, 11/16 Open End	1	153450
A3	Blade, 7 x 5/8 x .060	1	153441
A4	Owner's Manual, 370EXP	1	160084
A5	Warranty Card	1	155037
A6	Assembly, Rip Guide	1	134551-MK
	A6A) Rip Guide (comp)	1	134551
	A6B) Knob, Rubber (1/4-20x3/4)	1	159428-1
A7	Carton, Accessory Pack	1	153366
A8	Sell Sheet, Tile Accessory	1	156915
B	Assembly, Blade Guard, 7"	1	154811-MK
B1	Guard, 7" Blade (comp)	1	154811
	Guard, 7" Blade (raw)	1	154810
B2	Elbow, 1/8 MNPT X 1/4 BARB 90° Brass	1	154652
B3	Knob, Davies	1	151681
B4	Washer, 5/16 SAE Flat	2	151754
B5	Wingnut, 5/16-18 Nylok	1	151746
C	Carton	1	n/a
C1	Carton, MK-370EXP	1	160044
D	Assembly, Cutting Head	1	n/a
D1	Cutting Head (Comp)	1	159937
	Cutting Head (Raw)	1	159936
D2	Helicoil, 3/8-16x3/8	1	153486
D3	Screw, Slotted Pan Head, 10-32x3/4	1	151750
D4	Screw, Slotted Pan Head, 10-32x1	1	151751
D5	Nut, Hex 10-32	2	151749
D6	Screw, Hex Head, 1/4-20x3/4	1	152370
D7	Nut, Hex, 1/4-20	1	151893
D8	Knob, Tri Plastic	1	156770-01
D9	Label, Warning, Read Owner's Manual	1	155806
D10	Label, Serial Number, UL/CSA Mark	1	157249-04
D11	Cover, Splash	1	160279
D12	Screw, Hex Head, 1/4-20x3/8	1	153526
E	Frame	1	n/a
E1	Frame	1	159935
E2	Pan, Water	1	160041
E3	Screw, Shoulder, Soc Head, 1/4-20 x 1	1	160045
F	Assembly, Guide Bar, 3/4 Dia	1	159942-MK
F1	Bar, Guide, 3/4 Dia	1	159942
	Steel, C1045 Chromed rod, 3/4 Dia x 2.25'	1	154186
F2	Screw, 5/16-18 X 1 Hex Head Cap	2	151743
F3	Washer, 5/16 Split Lock	2	151747
F4	Washer, 5/16 SAE Flat	2	151754
G	Linear Bearing, 3/4 Dia	1	n/a
G1	Bearing, Multilube	2	152227

**MK-370 EXP PARTS LIST (cont...)**

H	Assembly, 120v Motor	1	160053
H1	Motor, 120v/5.3A, Sanko	1	156428-S
H2	Label, Caution, GFCI, 1 X 2 1/8	1	155678
H3	Label, Caution, Receptacle, 1 X 2 1/8	1	154822
H4	Screw, 10-32 X 5/8 Flat Head Phillips Cap	4	157554
H5	Flange, Blade	2	135830
H6	Nut, 5/8-18	1	135848
J	Assembly, Motor Mount	1	160052
J1	Motor Mount (Comp)	1	159941
	Motor Mount (Raw)	1	159940
J2	Washer, 5/16 Split Lock	1	151747
J3	Screw, 5/16-18 x 2-1/2 Hex Head Cap, Full Thread	1	151748
J4	Knob, Davies	1	151681
J5	Bolt, Shoulder, Soc Head, 1/2 x 1/2	2	151753
J6	Bolt, Shoulder, Soc Head, 5/16 x 5/8	1	152137
J7	Washer, 5/16 SAE Flat	1	151754
K	Assembly, Post Cover	1	159958-MK
K1	Cover, Post (comp)	1	159958
	Cover, Post (raw)	1	159956
K2	Screw, ¼-20 x 1/4 Socket Head Set	3	157528
K3	Label, 370EXP Model	1	160054
L	Assembly, Roller Wheel	1	151756
L1	Bracket, Roller Wheel	1	154021
L2	Wheel, Roller	1	151799
L3	Screw, ¼-20 X 1 ¼ Hex Head Cap	1	157145
L4	Washer, ¼ SAE Flat	1	151915
L5	Nut, ¼-20 Hex	1	151893
M	Table		n/a
M1	Table (Comp)	1	159939
	Table (Raw)	1	159938
M2	Screw, 5/16-18 X 1 Hex Head Cap	2	151743
M3	Washer, 5/16 Split Lock	2	151747
M4	Washer, 5/16 SAE Flat	2	151754
N	Assembly, PES-100 120v Water Pump	1	155987-MK
N1	Pump, Water, PES-100 120v	1	155987
N2	Hose, Vinyl, ¼ ID x 2'	1	132951
N3	Clamp, Flow, ¼-1/2	1	154394

## **THEORY OF DIAMOND BLADES**

Diamond blades do not really cut; they grind the material through friction. Diamond crystals, often visible at the leading edge and sides of the rim/segment, remove material by scratching out particles of hard, dense materials, or by knocking out larger particles of loosely bonded abrasive material.

This process eventually cracks or fractures the diamond particle, breaking it down into smaller pieces. As a result, a diamond blade for cutting soft, abrasive material must have a hard metal matrix composition to resist this erosion long enough for the exposed diamonds to be properly utilized.

Conversely, a blade for cutting a hard, non-abrasive material must have a soft bond to ensure that it will erode and expose the diamonds embedded in the matrix. These simple principles are the foundation of “controlled bond erosion”.



### **Types of Cutting**

There are two basic types of cutting-Dry or Wet. The choice of which type of blade to use depends on:

- The requirements of the job
- The machine/tool utilizing the diamond blade
- The preference of the operator







In the case of DRY cutting, the overwhelming popularity and quantity of hand-held saws and the flexible nature of MK Diamond blades to professionally handle most ceramic, masonry, stone and concrete materials, make the DRY cutting blade a very attractive tool. When using a DRY blade, the user must be aware of distinct operating practices to ensure optimum performance. DRY cutting blades require sufficient airflow about the blade to prevent overheating of the steel core. This is best accomplished by shallow, intermittent cuts of the material with periods of “free-spinning” (for several seconds) between each cut, to maximize the cooling process.

For WET cutting applications, MK has the exact blade to compliment both the material to be cut and the wet cutting machine to be used. During cutting operations, liberal amounts of water act as a coolant to support the cutting effectiveness and longevity of the WET blade. Additionally, using water adds to the overall safety of cutting operations by keeping the dust signature down.

Know All You Can About the Material You Wish to Cut

# ACCESSORIES

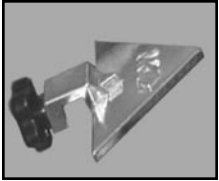
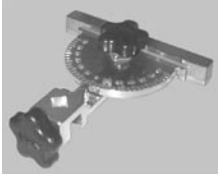
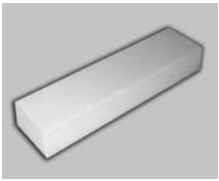
## ACCESSORIES

ITEM	NUMBER	DESCRIPTION	
1.	139295	MK-200, 7 x 5/8 Arbor	
2.	139311	MK-215, 7 x 5/8 Arbor	
3.	158434	MK-225, 7 x 5/8 Arbor	
4.	153293	MK-315, 7 x 5/8 Arbor	
5.	134577-MK	Dual 45° Flat Angle Guide	
6.	134569-MK	90° Protractor	
8.	152792	Dressing Stone	
9.	152610	Ground Fault Circuit Interrupter	
10.	160131	Stand	

# ORDERING & RETURN INSTRUCTIONS

## ORDERING INFORMATION

You may order MK Diamond products through your local MK Diamond distributor or, you may order direct from MK Diamond.

NOTE: There is a \$25.00 minimum order when ordering direct from MK Diamond. All purchases must be made using VISA or MasterCard.

When ordering direct from MK Diamond, please have the following information ready before calling:

- The Model Number of the saw
- The Serial Number of the saw
- Where the saw was purchased and when
- The Part Number for the part(s) being ordered
- The Part Description for the part(s) being ordered

All parts may be ordered by calling toll free to – 800 421-5830 or 310 539-5221 and asking for Customer Service. For technical questions, call – 800 474-5594.

## RETURN MATERIALS POLICY

To expedite the service relative to the return of a product purchased through MK Diamond, please observe the following:

NOTE: When returning all items, they must have been purchased within the previous twelve (12) months.

- Have the Model Number of the saw
- Have the Serial Number of the saw
- Have the location of where the saw was purchased
- Have the date when the saw was purchased
- Contact Customer Service for approval to return the item(s)
- Obtain a Returned Goods Number (RGA) authorizing the return
- Follow the packaging instructions in the following section
- Ensure your item(s) are prepaid to the destination

For returned items, call toll free to – 800 421-5830 or 310 539-5221 and ask for Customer Service. For technical questions, call – 800 474-5594 or 310 257-2845.

## PACKAGING INSTRUCTIONS

- Remove the Blade guard and Support Angle Assembly
- Dry the saw before shipping
- When packing, include the following: MK-370 EXP, Diamond Blade, Blade guard and Support Angle Assembly and Adjustable Cutting Guide (Other Accessories are not required)
- Package the unit in its original container or one of comparable size (do not ship the unit partially exposed)
- Ensure all parts are secured in the packaging to prevent moving

## AUTHORIZED SERVICE CENTERS

For quicker repair time, you may contact MK Diamond Customer Service, toll free, at 800 421-5830 or 310 539-5221 for the Authorized Service Center closest to you or visit our web site at [www.mkdiamond.com](http://www.mkdiamond.com). For technical questions, call – 800 474-5594.



TILE SAW  
OWNER'S MANUAL &  
OPERATING INSTRUCTIONS

**CALIFORNIA  
PROPOSITION 65 MESSAGE**

SOME DUST CREATED BY POWER SANDING, SAWING,  
GRINDING, DRILLING, AND OTHER CONSTRUCTION  
ACTIVITIES CONTAIN CHEMICALS KNOWN (TO  
THE STATE OF CALIFORNIA) TO CAUSE CANCER,  
BIRTH DEFECTS OR OTHER REPRODUCTIVE HARM.

SOME EXAMPLES OF THESE  
CHEMICALS ARE:

- LEAD FROM LEAD-BASE  
PAINTS
- CRYSTALLINE SILICA,  
FROM BRICKS AND CEMENT  
AND OTHER MASONRY PRODUCTS  
AND
- ARSENIC AND CHROMIUM, FROM CHEMICALLY  
TREATED LUMBER.

YOUR RISK FROM THESE EXPOSURES VARIES DEPENDING  
ON HOW OFTEN YOU DO THIS TYPE OF WORK. TO REDUCE  
YOUR EXPOSURE TO THESE CHEMICALS, WORK IN A WELL-  
VENTILATED AREA, AND WORK WITH APPROVED SAFETY  
EQUIPMENT, SUCH AS THOSE DUST MASKS THAT ARE  
SPECIALLY DESIGNED TO FILTER OUT  
MICROSCOPIC PARTICLES.



**MK DIAMOND PRODUCTS, INC  
1315 STORM PARKWAY  
TORRANCE, CA 90509-2808  
(310) 539-5158  
[www.mkdiamond.com](http://www.mkdiamond.com)**

**MK-370 EXP TILE SAW**