



MK-101 w/JCS Stand

**TILE SAW
OWNER'S MANUAL &
OPERATING INSTRUCTIONS**



CAUTION:
Read all safety and
operating instructions
before using this
equipment

Enter the Serial Number of your new saw in the space below. The Serial Number is located on the left side of the blade guard.

SERIAL NUMBER:

NOTE:

For your (1) one year warranty to be effective, complete the warranty card (including the Serial Number and mail it in as soon as possible.

INTRODUCTION

We at MK Diamond want to congratulate you on selecting the MK-101 Tile Saw. We are certain that you will be pleased with your purchase. MK Diamond takes pride in producing the finest products in the industry.

Operated correctly, your MK-101 should provide you with years of quality service. In order to help you, we have included this manual. This owners manual contains information necessary to operate and maintain your MK-101 safely and correctly. Please take a few minutes to familiarize yourself with the MK-101 by reading and reviewing this manual.

If you should have questions concerning your MK-101, please feel free to call our friendly customer service department at: 800 421-5830

Regards,

MK Diamond

TABLE OF CONTENTS

	Page
SAFETY:	4
Safety Messages	4
Damage Prevention Message	4
General Safety Precautions and Hazard Symbols	4
California Proposition 65 Message	6
Electrical Requirements and Grounding Instructions	7
Safety Label Locations	9
Tile Saw Specific Warnings	9
Product Specifications	10
UNPACKING, TRANSPORT, UNIVERSAL STAND, and ASSEMBLY	
Unpacking	11
Contents	11
Transport	11
JCS STAND: Key components for Set Up	12
JCS Stand – Set Up for Operation	13
JCS Stand – Take Down Instructions	14
Table Locking Instructions	15
Assembly	16
SETUP, ADJUSTMENT AND OPERATION	
Setup	18
Adjustment and Operation	21
Cleanup	27
MAINTENANCE AND TROUBLESHOOTING	
Maintenance	29
Troubleshooting	36
EXPLODED VIEW AND PARTS LIST	
Exploded View	40
Parts List	43
THEORY	
Theory of Diamond Saws	46
ACCESSORIES	
Accessories	47
ORDERING and RETURN INSTRUCTIONS	
Ordering Information	48
Return Material Policy	48
Packaging Instructions	48
Authorized Service Centers	48

SAFETY

Read and follow all safety, operating and maintenance instructions. Failure to read and follow these instructions could result in injury or death to you or others. Failure to read and follow these instructions could also result in damage and/or reduced equipment life.

SAFETY MESSAGES:

Safety messages inform the user about potential hazards that could lead to injury, death and/or equipment damage. Each safety message will be preceded by one of the following (3) three words that identify the severity of the message.

▲ DANGER

Not following instructions **WILL** lead to **DEATH** or **SERIOUS INJURY**

▲ WARNING

Not following instructions **COULD** lead to **DEATH** or **SERIOUS INJURY**

▲ CAUTION

Not following instructions **CAN** lead to injury

DAMAGE PREVENTION AND INFORMATION MESSAGES:

A Damage Prevention Message is to inform the user of important information and/or instructions that could lead to equipment or other property damage if not followed. Information Messages convey information that pertains to the equipment being used. Each message will be preceded by the word NOTE, as in the example below.

NOTE:

Equipment and/or property damage may result if these instructions are not followed.

GENERAL SAFETY PRECAUTIONS AND HAZARD SYMBOLS:

In order to prevent injury, the following safety precautions and symbols should be followed at all times!

Safety Precautions:

KEEP GUARDS IN PLACE.



In order to prevent injury, keep guards in place and in working order at all times.

REMOVE ADJUSTING KEYS AND WRENCHES.

Form a habit of checking to see that keys and adjusting wrenches are removed from the power tool before it is turned on.

KEEP WORK AREA CLEAN.

Cluttered work areas and benches invite accidents.

DO NOT USE IN DANGEROUS ENVIRONMENTS.

Do not use power tools in damp or wet locations nor expose them to rain. Always keep the work area well lighted.

KEEP CHILDREN AWAY.

All visitors and children should be kept a safe distance from work area.

MAKE THE WORKSHOP KID PROOF.

Make the workshops kid proof by using padlocks, master switches or by removing starter keys.

DO NOT FORCE THE TOOL.

A power tool will do a job better and safer operating at the rate for which it was designed.

USE THE RIGHT TOOL.

Do not force a tool or an attachment, to do a job that it was not designed to do.

SAFETY

USE THE PROPER EXTENSION CORD.

If using an extension cord make sure it is in good condition first. When using an extension cord, be sure to use one heavy enough to carry the current your product will draw. An undersized cord will cause a drop in line voltage that will result in a loss of power and overheating. TABLE 1, Page 8 shows the correct AWG size to use depending on cord length and nameplate ampere rating. If in doubt, use the next heavier gage. The smaller the gage number, the heavier the cord.

WEAR PROPER APPAREL.

Do not wear loose clothing, gloves, neckties, rings, bracelets, or other jewelry that may be caught in moving parts. Non-slip footwear is recommended. Wear protective hair covering to contain long hair.

ALWAYS USE SAFETY GLASSES.



Safety glasses should always be worn when working around power tools. In addition, a face, dust mask or respirator should be worn if a cutting operation is dusty. Everyday eyeglasses only have impact resistant lenses and may not prevent eye injury; they are NOT safety glasses.

SECURE WORK.

Clamps or a vise should be used to hold work whenever practical. Keeping your hands free to operate a power tool is safer.

DO NOT OVERREACH.

Keep proper footing and balance at all times by not overreaching.

MAINTAIN TOOLS WITH CARE.

Keep tools clean for the best and safest performance. Always follow maintenance instructions for lubricating, and when changing accessories.

DISCONNECT TOOLS.

Power tools should always be disconnected before servicing or when changing accessories, such as blades, bits, cutters, and the like.

REDUCE THE RISK OF UNINTENTIONAL STARTING.



Make sure the switch is in the OFF position before plugging in the saw.

USE RECOMMENDED ACCESSORIES.

Consult the owner's manual for recommended accessories. Using improper accessories may increase the risk of personal or by-stander injury.

NEVER STAND ON THE TOOL.

Serious injury could occur if a power tool is tipped, or if a cutting tool is unintentionally contacted.

CHECK FOR DAMAGED PARTS.

Before using a power tool, check for damaged parts. A guard or any other part that is damaged should be carefully checked to determine it would operate properly and perform its intended function. Always check moving parts for proper alignment or binding. Check for broken parts and mountings and all other conditions that may affect the operation of the power tool. A guard, or any damaged part, should be properly repaired or replaced.

DIRECTION OF FEED.

Always feed work into a blade or cutter against the direction of rotation. A blade or cutter should always be installed such that rotation is in the direction of the arrow imprinted on the side of the blade or cutter.

NEVER LEAVE A TOOL RUNNING UNATTENDED – TURN POWER OFF.

Do not leave a tool until it comes to a complete stop. Always turn a power tool OFF when leaving the work area, or, when a cut is finished.

SAFETY

Hazard Symbols:

ELECTRICAL SHOCK!



Never touch electrical wires or components while the motor is running. Exposed, frayed or worn electrical motor wiring can be sources of electrical shock that could cause severe injury or burns.

ACCIDENTAL STARTS!



Make sure the switch is in the OFF position before plugging in the saw.

ROTATING OR MOVING PARTS!



Keep hands, feet, hair, and clothing away from all moving parts to prevent injury. Never operate a power tool with covers, shrouds, or guards removed.

⚠WARNING

Sawing and drilling generates dust. Excessive airborne particles may cause irritation to eyes, skin and respiratory tract. To avoid breathing impairment, always employ dust controls and protection suitable to the material being sawed or drilled; See OSHA (29 CFR Part 1910.1200). Diamond Blades improperly used are dangerous. Comply with American National Standards Institute Safety Code, B7.1 and, Occupational Safety and Health Act covering Speed, Safety Guards, Flanges, Mounting Procedures, General Operating Rules, Handling, Storage and General Machine Conditions.

CALIFORNIA PROPOSITION 65 MESSAGE:

⚠WARNING

Some dust created by power sanding, sawing, grinding, drilling, and other construction activities contain chemicals known [to the State of California] to cause cancer, birth defects or other reproductive harm. Some examples of these chemicals are:

- Lead, from lead-based paints
- Crystalline silica, from bricks and cement and other masonry products
- Arsenic and chromium, from chemically treated lumber

For further information, consult the following sources:

<http://www.osha-slc.gov/sltc/silicacrystalline/index.html>

http://www.oehha.org/prop65/out_of_date/6022kLstA.html

Your risk from these exposures varies depending on how often you do this type of work. To reduce your exposure to these chemicals, work in a well-ventilated area, and work with approved safety equipment, such as those dust masks that are specially designed to filter out microscopic particles.

SAFETY

ELECTRICAL REQUIREMENTS AND GROUNDING INSTRUCTIONS:

In order to prevent potential electrical shock and injury, the following electrical safety precautions and symbols should be followed at all times!

⚠ WARNING



In case of a malfunction or breakdown, grounding provides a path of least resistance for electric current to reduce the risk of electric shock. This tool is equipped with an electric cord having an equipment-grounding conductor and a grounding plug. The plug must be plugged into a matching outlet that is properly installed and grounded in accordance with all local codes and ordinances.

- Do not modify the plug provided – if it will not fit the outlet; have the proper outlet installed by a qualified electrician
- Improper connections of the equipment-grounding conductor can result in a risk of electric shock. The equipment-grounding conductor is the insulated conductor that has an outer surface that is green, with or without yellow stripes. If repair or replacement of the electric cord or plug is necessary, do not connect the equipment-grounding conductor to a live terminal
- Check with a qualified electrician or service personnel if the grounding instructions are not completely understood, or if in doubt as to whether the tool is properly grounded
- Use only 3-wire extension cords that have 3-prong grounding plugs and 3-pole receptacles that accept the tool's plug
- Repair or replace a damaged or worn cord immediately

⚠ WARNING This tool is intended for use on a circuit that has an outlet that looks like the one shown in Sketch A of Figure 1. The tool has a grounding plug that looks like the plug illustrated in Sketch A of Figure 1. A temporary adapter, which looks like the adapter illustrated in sketches B and C,

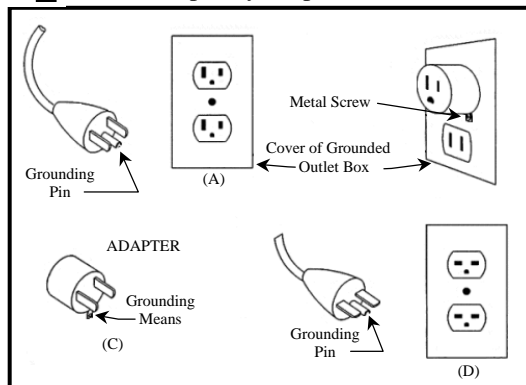

may be used to connect this plug to a 2-pole receptacle as shown in Sketch B, if a properly grounded outlet is not available. The temporary adapter should be used only until a properly grounded outlet can be installed by a qualified electrician. The green-colored rigid ear, lug, and the like, extending from the adapter, must be connected to a permanent ground such as a properly grounded outlet box.

NOTE: Use of a temporary adapter is not permitted in Canada.

FIGURE 1

⚠ WARNING To reduce the risk of electrocution, keep all connections dry and off the ground.



A Ground Fault Circuit Interrupter (GFCI) should be provided on the circuit(s) or outlet(s) to be used for the Saw. Receptacles are available having built-in GFCI protections and may be used for this measure of safety.

When using an extension cord, the GFCI should be installed closest to the power source, followed by the extension cord and lastly, the saw.

⚠ WARNING The pump requires a GFCI. To reduce risk of electric shock when operating the saw with the pump plugged into the 3-pole receptacle on the motor, connect the saw to a GFCI outlet. See the pump manual and informational tags enclosed separately for all pump information.



⚠ CAUTION Shock Hazard. For replacement, use only an identical MK pump, model PE1 part #151271.

NOTE: Do not run the pump dry. Also, be sure to disconnect and remove the pump when cutting dry.

SAFETY

When using the water pump plugged into the water pump receptacle, the saw must be plugged into a properly installed and grounded GFCI outlet See Sketch A of Figure 2. If a GFCI outlet is not available, MK Diamond has available as an accessory item, a plug-in GFCI that may be plugged into a properly installed and grounded 3-pole outlet. See Sketch A of Figure 2.

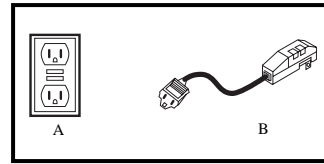

FIGURE 2

⚠ WARNING To avoid the possibility of the appliance plug or receptacle getting wet, position the saw to one side of a wall mounted receptacle. This will prevent water from dripping onto the receptacle or plug. A "drip loop," shown in Figure 3, should be arranged by the user to properly position the power cord relative to the power source.

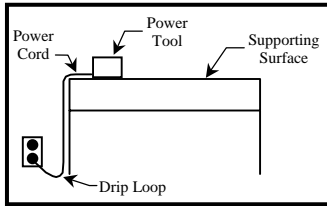

FIGURE 3

The "drip loop" is that part of the cord below the level of the receptacle, or the connector, if an extension cord is used. This method of positioning the cord prevents the travel of water along the power cord and coming in contact with the receptacle.

If the plug or receptacle gets wet, DO NOT unplug the cord. Disconnect the fuse or circuit breaker that supplies power to the tool. Then unplug and examine for presence of water in the receptacle.

⚠ WARNING Use only extensions cords that are intended for outdoor use. These extension cords are identified by a marking "Acceptable for use with outdoor appliances; store indoors while not in use." Use only extension cords having an electrical rating not less than the rating of the product. Do not use damaged extension cords. Examine extension cords before using and replace if damaged. Do not abuse extension cords and do not yank on any cord to disconnect. Keep cords away from heat and sharp edges. Always disconnect the extension cord from the receptacle before disconnection the product form the extension cord.



⚠ WARNING

To reduce the risk of electrocution, keep all connections dry and off the ground. Do not touch the plug with wet hands.

⚠ WARNING Use of undersize extension cords result in low voltage to the motor that can result in motor burnout and premature failure. MK Diamond warns that equipment returned to us showing signs of being run in a low voltage condition, through the use of undersized extension cords will be repaired or replaced totally at the customers expense. There will be no warranty claim.



To choose the proper extension cord,

- Locate the length of extension cord needed in TABLE 1 below.
- Once the proper length is found, move down the column to obtain the correct AWG size required for that length of extension cord.

Extension Cord Minimum Gage for Length

Volts	Total Length of Cord in Feet			
	25 ft.	50 ft.	100 ft.	150 ft.
120V	AWG 14	AWG 12	AWG Not Recommended	AWG Not Recommended

TABLE 1

LOCK OUT METHOD:

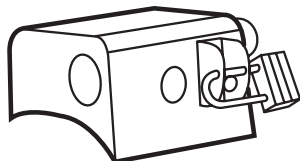

In order to help prevent accidental starting and to help make your workshop "Kidproof," this saw is provided with a means to deactivate the functioning of the motor switch. The switch is equipped with a Lockout plate that can be used with a lock to prevent the movement of the toggle switch. With the toggle switch unable to move the motor cannot be turned on. Removing the lock reactivates the switch.

SAFETY

SAFETY LABEL LOCATIONS:

Safety labels are located according to Figures 1 through 4 below. The labels contain important safety information. Please read the information contained on each safety label. These labels are considered a permanent part of your saw. If a label comes off or becomes hard to read, contact MK Diamond or your dealer for a replacement

Item	Location	Description	Part No.
1.	Motor Front	Warning Read and Follow Operating Instructions	155806
1B.	Motor Side	Label, Caution, GFCI, 1 X 2 1/8	155678
2.	Blade Side	Saw Serial Number Specifications	157500
3.	Motor Rear	Service or Warranty Information	155038
4A	Motor Rear	Extension Cord Warnings	155672
4B	Motor Rear	Label, Caution, 5 Amp Max., 1 X 2-1/8	154822
4C	Motor Rear	Motor Specifications	N/A
5A	Pump Left Side	Warning Connect to Grounded Receptacle	N/A
5B	Pump Right Side	Pump Specifications	N/A

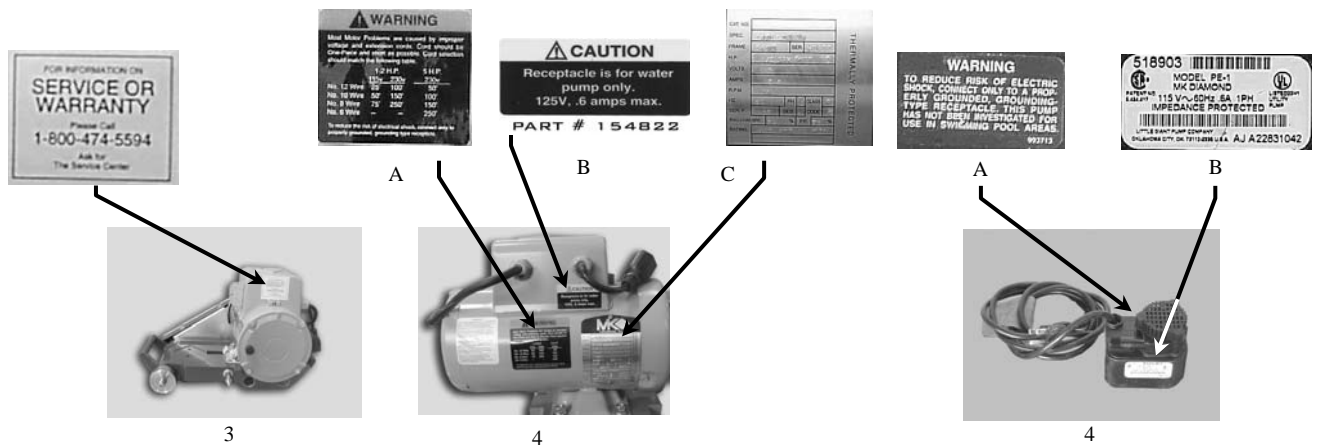

TILE SAW SPECIFIC WARNINGS:

⚠️WARNING

Wear eye protection.

Disconnect saw before servicing, when changing cutting blades, and cleaning.

Use tool only with smooth edge cutting blades free of openings and grooves.

Replace damaged cutting blade before operating.

SAFETY

PRODUCT SPECIFICATIONS:

The MK-101 is a versatile Tile Saw. Operated and used according to this manual, the MK-101 will provide years of dependable service.

General Description:

The MK-101 Tile Saw is engineered as a tabletop or stand mounted wet tile saw. The saw includes a powerful 115v totally enclosed capacitor start Baldor motor with a thermal protective overload. The saw is capable of cutting tile up to twenty (20) inches in length, or diagonal cutting tile up to fourteen (14) inches. The saw can cut an object three and one-half (3-1/2) inches thick in one pass.

Motor Specifications:

Motor specifications for the MK-101 are listed in Table 2 below.

Voltage	115 v
Overall Amperage	13 a
Motor Only Amperage	12.4 a
Frequency	60 Hz
RPM	3450 rpm
Horse Power	1.5 hp
Weight	128 lbs

Table 2

Thermal Overload Protection:

The motor is protected by a thermal overload equipped with a manual reset.

Blade Capacity:

The MK-101 uses a ten (10) inch (254mm) diameter, wet cutting continuous rim, MK Diamond blade with a one-sixteenth 1/16 inch (1.5875 mm) cutting width and a five-eighths (5/8) inch (15.875 mm) arbor.

Tile Types:

The MK-101 can cut a variety of tile types including Porcelain, Terracotta, Marble, Quarry and Slate, or almost any other non-ferrous material.

NOTE:

The MK-101 is not designed to cut plastic or ferrous (metals) material.

The following warnings are for the MK-101 w/JCS Stand

WARNING

Read and understand all instructions

Maximum material load 35 lbs. (15.9kg)

Place unit on a hard level surface.

DO NOT use as ladder or scaffolding.

Always use with Safety Arm in place (see SET UP section on pg. 12)

UNPACKING, TRANSPORT, UNIVERSAL STAND and ASSEMBLY

UNPACKING:

Your MK-101 has been shipped from the factory thoroughly inspected. Only minimal assembly is required.
⚠CAUTION Use proper lifting techniques when lifting the MK-101.

CONTENTS:

In your container, you will find one (1) MK-101 frame and water basin, one (1) MK-101 Cutting, one (1) 10-inch wet cutting continuous rim diamond blade, one (1) adjustable cutting guide, one (1) bull nose cutting guide, one (1) electric water pump, one (1) pump discharge fitting, one (1) cooling transfer tube, one (1) flow adjusting clamp, one (1) drain plug, one (1) blade wrench, one (1) Table Clip, one (1) splash guard, one (1) owners manual, one (1) pump manual and one (1) warranty card.



MK-101 w JCS Stand & Water Basin



MK-101 Cutting Head



Diamond Blade

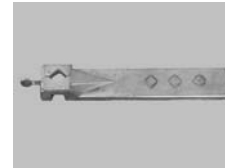

Adjustable Cutting Guide



Water Pump Clamp and Wing Screws



Electric Water Pump



Pump Discharge Fitting



Cooling Transfer Tube



Flow Adjusting Clamp



Drain Plug



Blade Wrench and Table Clip

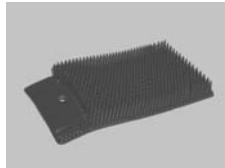

Splash Guard



Owners Manual



Pump Manual



Warranty Card

TRANSPORT:

- ⚠CAUTION**
1. The MK-101 weighs approximately one hundred and twenty eight (128) pounds.
 2. Never transport the MK-101 with water in the Water Basin.

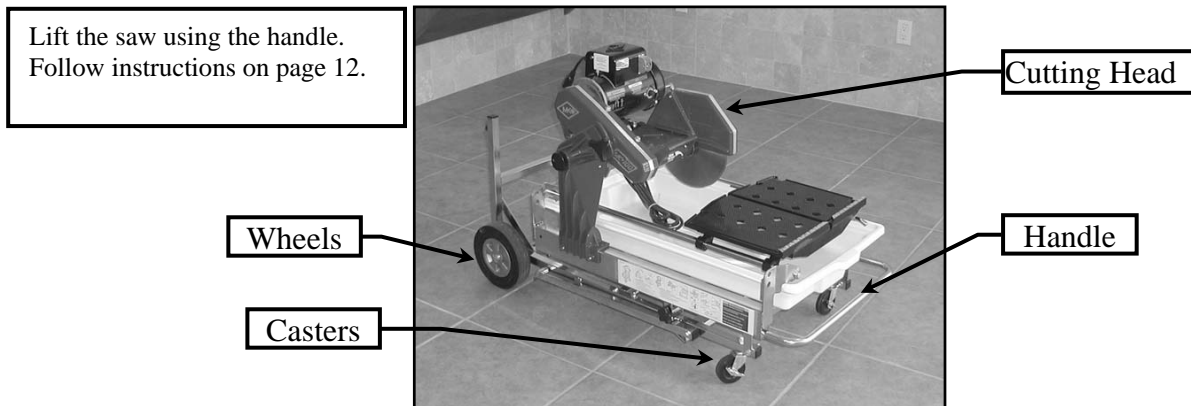

UNPACKING, TRANSPORT, JCS STAND and ASSEMBLY

JCS STAND: Key Components for Set Up

Note: Familiarize with the following components before proceeding to SET UP.

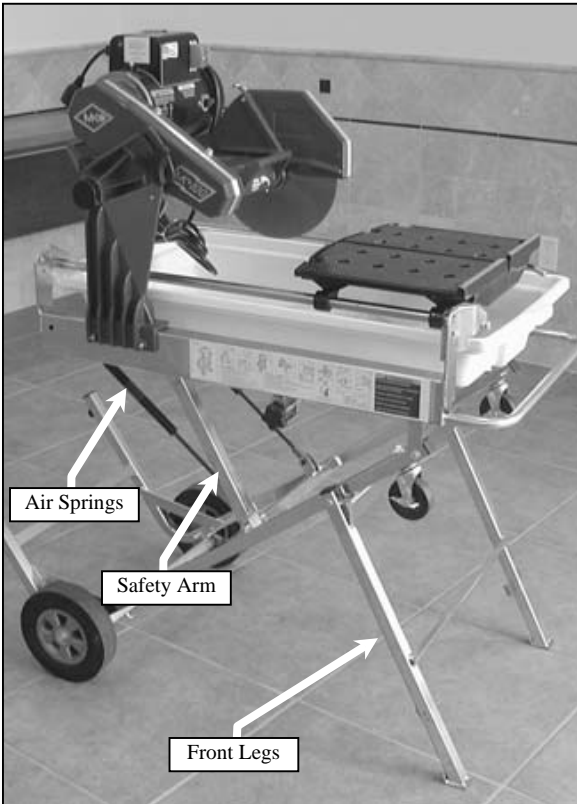
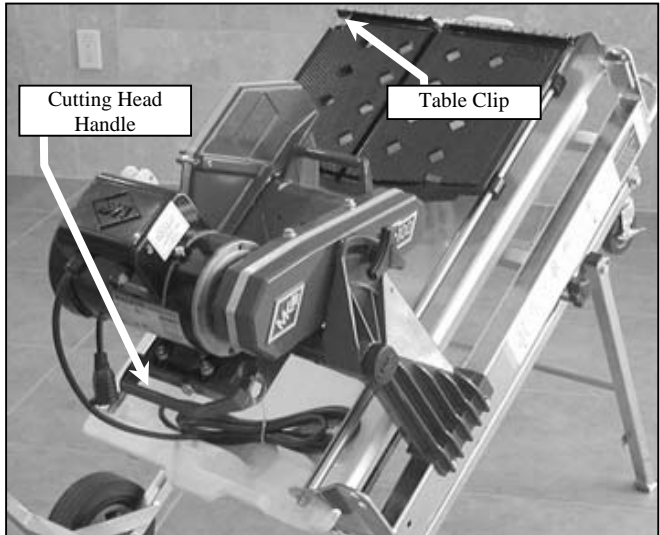
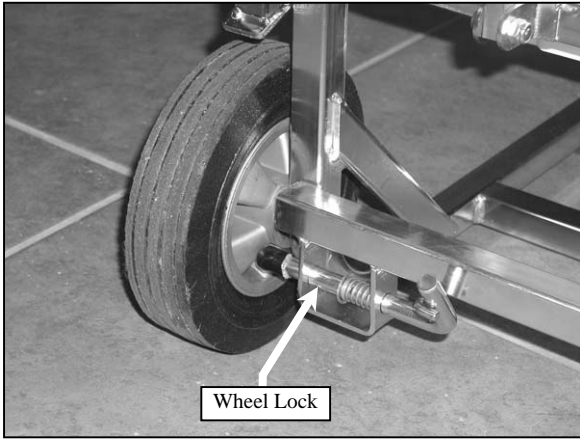
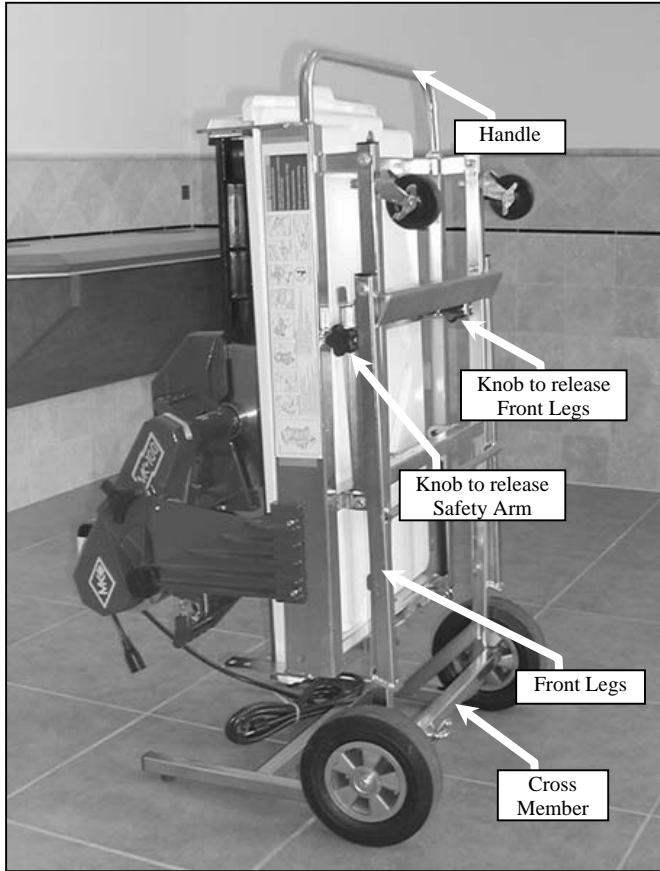

UNPACKING, TRANSPORT, JCS STAND and ASSEMBLY

JCS STAND - SET UP FOR OPERATION:

⚠CAUTION The MK-101 w/ JCS Stand weighs approximately one hundred and twenty eight (128) pounds. Read and understand all instructions. Failure to follow all instructions in SEQUENCE could result in serious injury.



(A)
Position Saw on a hard level surface

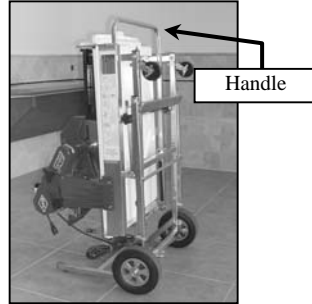

(B)
Hold the Saw from Handle and swing to Upright position



(C)
Locate Wheel Lock

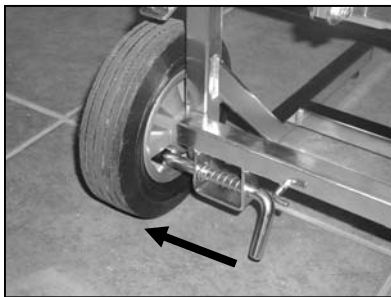

(D)
Lock Wheel

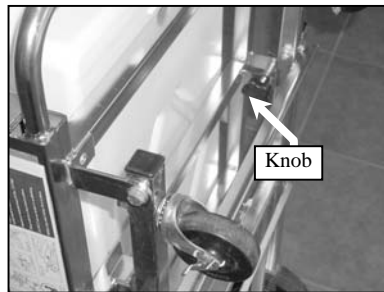

(E)
Locate the Knob to release Front Legs

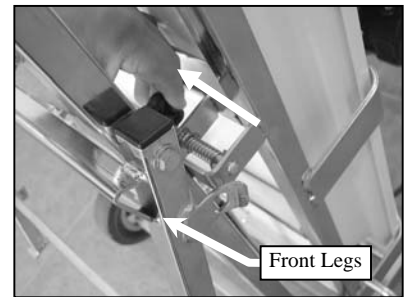

(F)
Pull Knob and Front Legs will be released



(G)
Place your foot on Cross Member for support



(H)
Hold from handle and swing down



(I)
Make sure to extend Front Legs as they swing down



(J)
Front Legs rest on the ground



(K)
Locate the Cutting Head Handle



(L)
Pull from the Cutting Head Handle until Air Springs are fully extended

UNPACKING, TRANSPORT, JCS STAND and ASSEMBLY



(M)
Air Springs are fully extended and saw is in Horizontal position

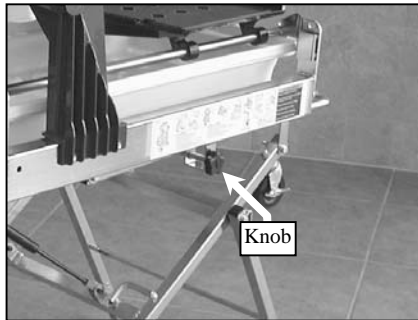

(N)
Locate the Knob to unlock the Safety Arm

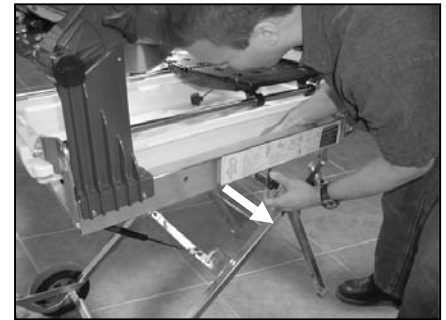

(O)
Pull Knob to unlock the Safety Arm
The Safety Arm will swing down as the Knob is pulled

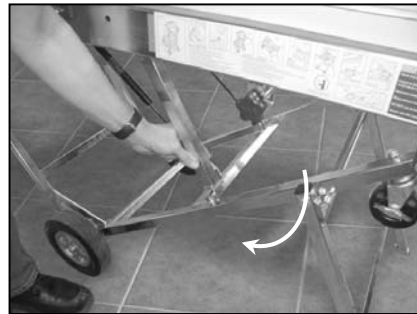

(P)
Ensure that Safety Arm rests on Frame



(Q)
Your Saw is ready!

JCS STAND - TAKE DOWN INSTRUCTIONS:

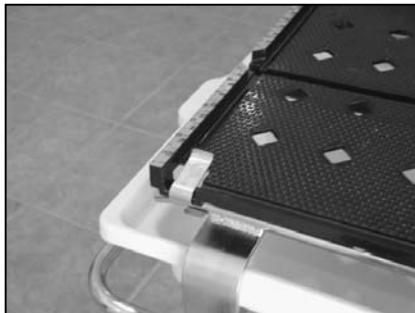

(A)
Lock Table in place with Clip
(See pg. 14 for instructions)

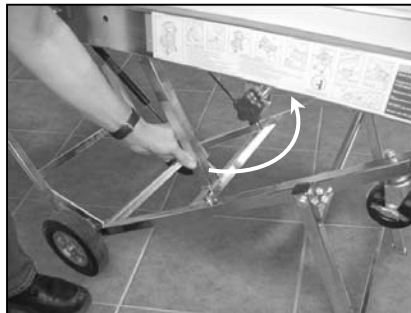

(B)
Swing up Safety Arm



(C)
Lock the Safety Arm with Knob



(D)
Push down on Cutting Head until Air Springs are fully compressed



(E)
Hold saw from Handle and swing up to upright position



(F)
Push legs against frame to lock in place with Knob

UNPACKING, TRANSPORT, JCS STAND and ASSEMBLY

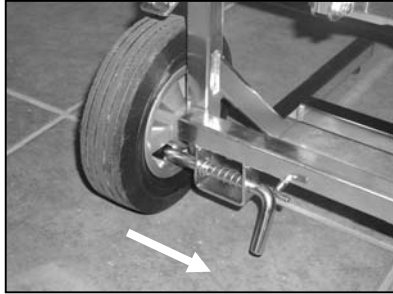

(G)
Unlock the wheel



(H)
Make sure that the wheel is properly unlocked



(I)
Your saw is ready for transport!

TABLE CLIP:



(A)
Slide table to the front

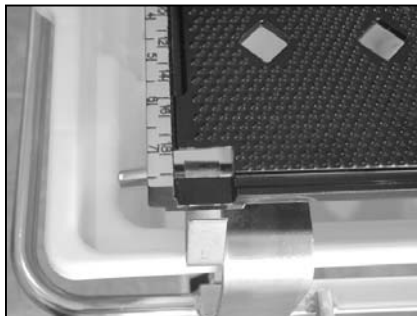

(B)
Line up Clip with Side Table Slot

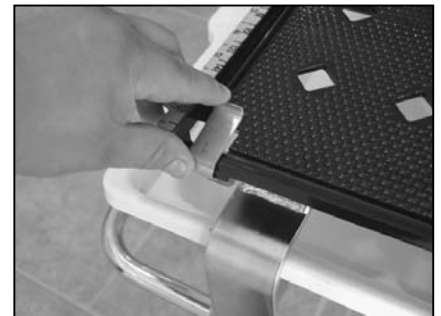

(C)
Swing clip over the side of the Table

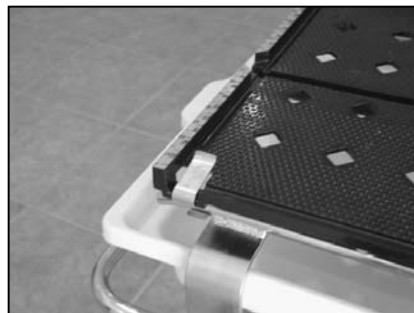

(E)
The clip secures the Table in place

UNPACKING, TRANSPORT, JCS STAND and ASSEMBLY

ASSEMBLY:

Follow the assembly instructions to prepare your MK-101 for operation.

1. Cutting Head Installation:

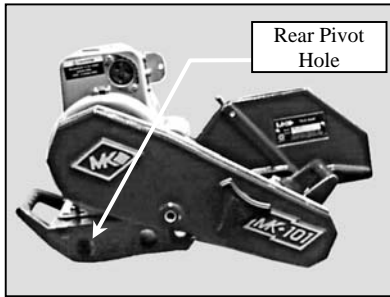

(A)
Locate Rear Pivot Hole
on Cutting Head

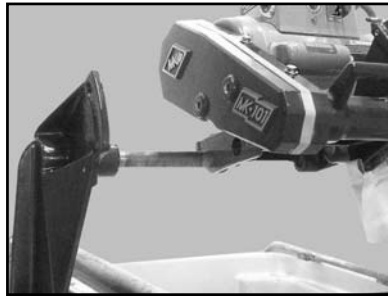

(B)
Align and insert cutting head onto
pivot pin

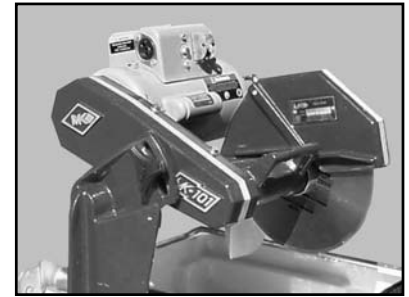

(C)
Install the Adjusting Knob

2. Diamond Blade Installation:

NOTE: When installing the Retaining Screw, do not "cross-thread" and DO NOT over tighten the screw.

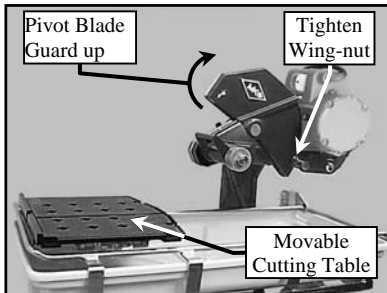

(A)
Position Movable Cutting Table
to the front of the saw and
raise the Blade Guard

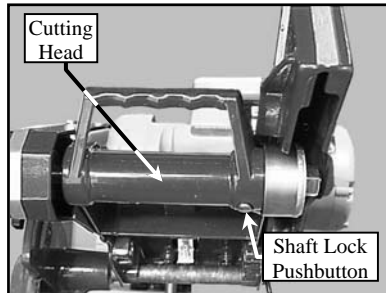

(B)
Locate the Shaft Lock pushbutton
on the underside
of the Cutting Head

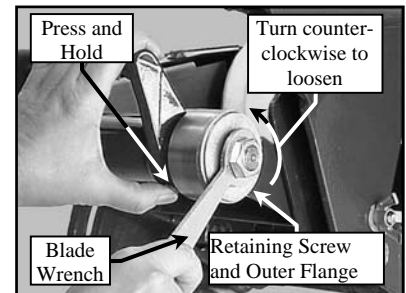

(C)
Depress and hold the Shaft Lock
pushbutton and remove Retaining
Screw and Outer Flange using
the Blade Wrench

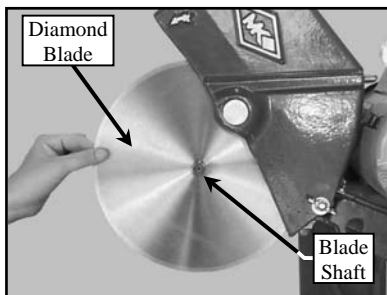

(D)
Install Diamond Blade
onto Blade Shaft

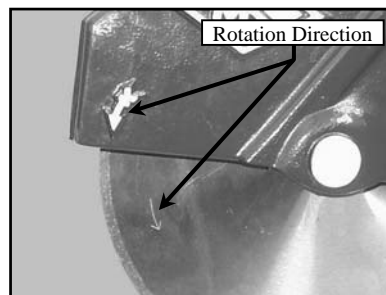

(E)
Verify the Blade is seated on
the Blade Shaft and direction
of rotation is correct

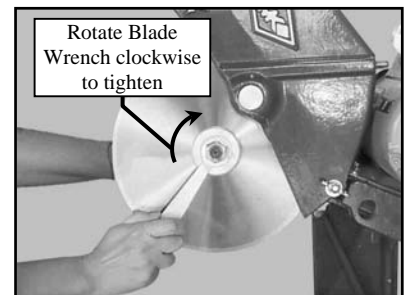

(F)
Install Retaining Nut and Outer
Flange, depress and hold the
Shaft Lock pushbutton and
Tighten

UNPACKING, TRANSPORT, JCS STAND and ASSEMBLY

3. Adjustable Cutting Guide Installation:

NOTE: The Adjustable Cutting Guide can be used on either side of the Diamond Blade.

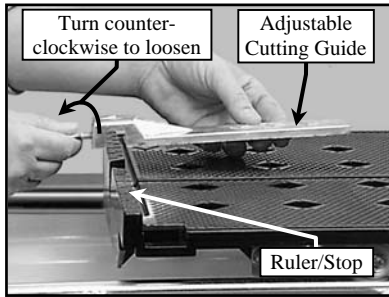

(A)
Loosen Adjustable Cutting Guide retaining thumbscrew and place it over the Movable Cutting Table Ruler/Stop

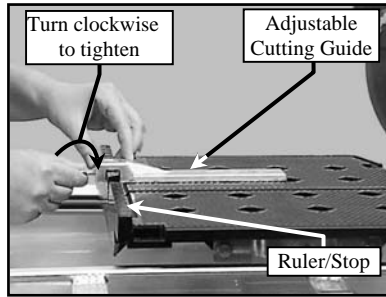

(B)
Place the Adjustable Cutting Guide onto the Movable Cutting Table Ruler/Stop and tighten the retaining thumbscrew

4. Splash Guard Installation:

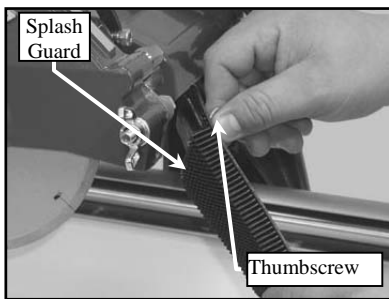

(A)
Install the retaining thumbscrew through the washer and Splash Guard then align to the hole found on back of the Blade Guard

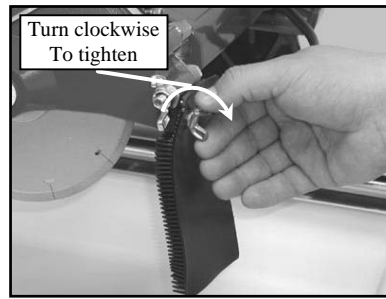

(B)
Install the Splash Guard onto the Blade Guard

5. Water Pump Preparation:

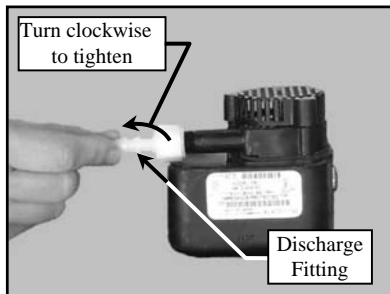

(A)
Install Water Pump Discharge Fitting

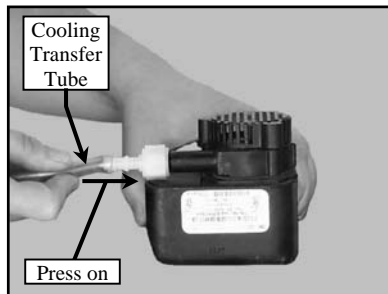

(B)
Press one end of the Cooling Transfer Tube onto the Water Pump Discharge Fitting

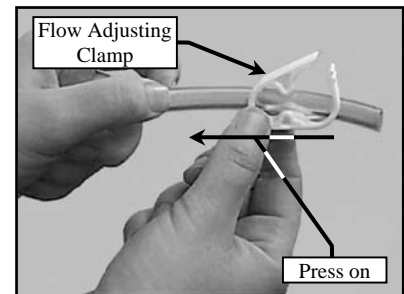

(C)
Slide Cooling Flow Adjusting Clamp onto the Cooling Transfer Tube

SETUP, ADJUSTMENT and OPERATION

SETUP:

1. Pre-start Inspection:

Prior to beginning work, a pre-start inspection of the saw should be performed.

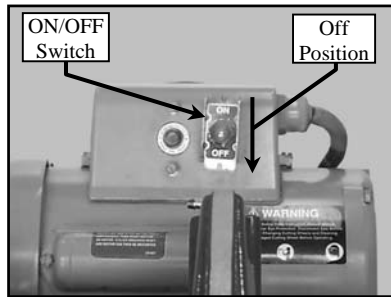

(A)
Ensure the ON/OFF Switch is in the OFF position

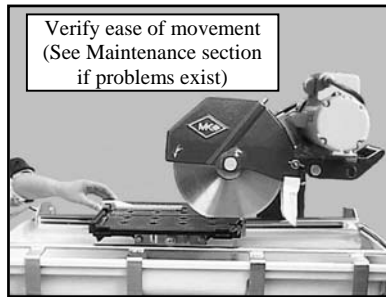

(B)
Verify the Movable Cutting Table moves freely

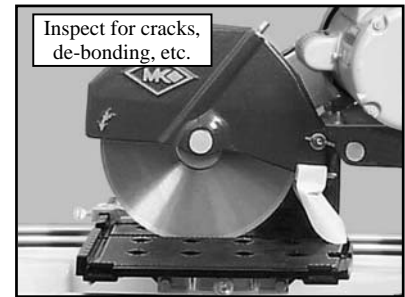

(C)
Inspect the Diamond Blade for damage – verify the blade is correct for the material being cut

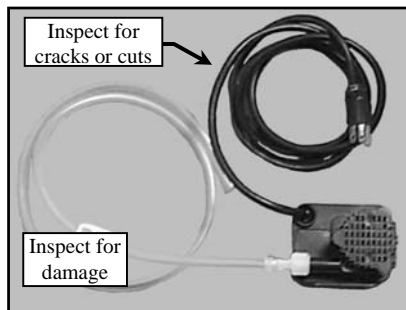

(D)
Inspect the Pump Assembly for damage – ensure the cord is free of cracks or cuts



(E)
Inspect the MK-101 for damage – ensure the cord is free of cracks or cuts

2. Connecting the Water Pump:

⚠ WARNING 1. To prevent the possibility of electrical shock, the MK-101 **MUST** be de-energized when connecting the Water Pump.



2. To prevent the possibility of electrical shock, use only MK Diamond qualified replacement parts

NOTE: To prevent pump damage, the Water Pump must be disconnected if cutting with a Dry Blade.

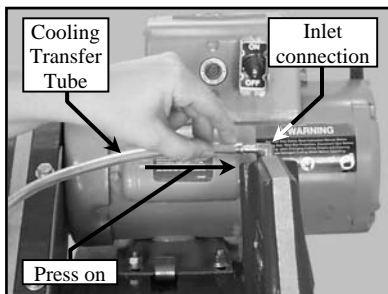

(A)
Connect the Cooling Transfer Tube to the inlet connection of the Blade Guard

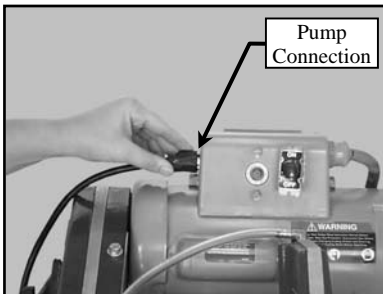

(B)
Connect the Water Pump power cord to the connection found on the back of the motor

SETUP, ADJUSTMENT and OPERATION

3. Water Pump Setup for Operation:

The Water Pump can be setup for operation in two ways, External Water Source or Re-circulation.

NOTE: If using a dry blade for operation, DO NOT connect the water pump.



(A)
Place Water Pump in Water Pan



(B)
Place Water Pump Clamp as shown



(C)
Secure Clamp with 1/4-20
wingscrews and nuts.

I. External Water Source:

This is the preferred method of cooling.

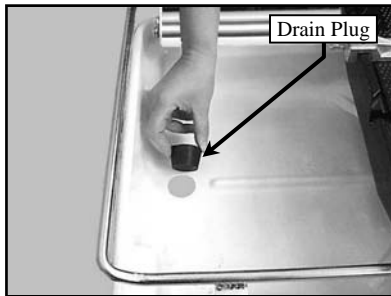

(A)
Remove the Drain plug

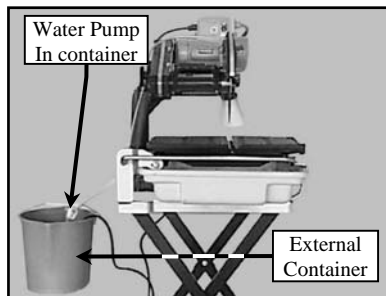

(B)
Place the Water Pump
In an external container

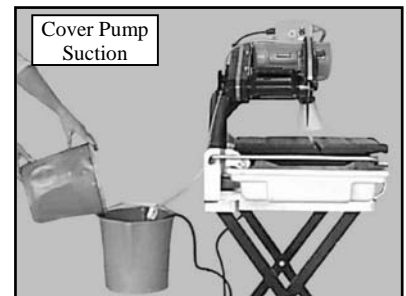

(C)
Fill the external container until
water completely covers the
Water Pump suction

II. Re-circulation:

NOTE: When using the re-circulation method, the water should be changed often for longer pump life.

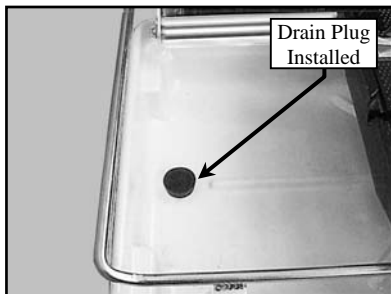

(A)
Ensure the Drain Plug is
Installed in the Water Basin

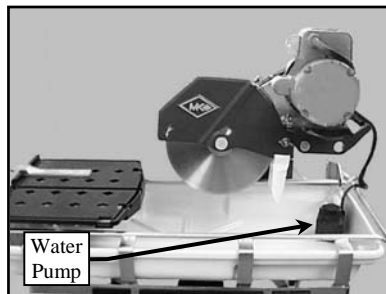

(B)
Place the Water Pump in the back
of the Water Basin.

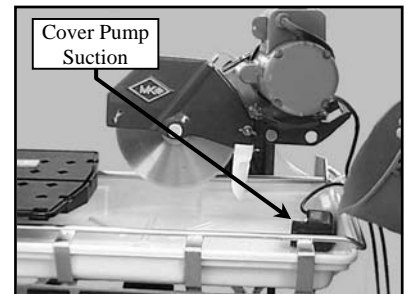

(C)
Fill the Water Basin until water
completely covers the
Water Pump suction

SETUP, ADJUSTMENT and OPERATION

4 MK-101 Setup for Operation:

- ⚠CAUTION** 1. Before powering or starting, check for damage that could prevent this equipment from proper operation or performing it's intended function. Check for binding and alignment of moving parts. Check for damaged, broken, or missing parts.
2. Verify the On/Off switch is in the OFF position.
3. Before connecting the MK-101 to a power supply, be sure the voltage, cycle and phase of the job site power source meet the requirements of TABLE 3

VOLTAGE:	115v
CYCLE:	60hz
PHASE:	1-phase

TABLE 3

4. If using an extension power cord, made sure, the length and wire gauge correspond to the requirements listed in TABLE 1 on page 9. An extension power cord that is too small in wire gauge (diameter), or too long in length, will cause the motor to overheat and could cause premature failure.
5. Use an approved Ground Fault Circuit Interrupter (GFCI)
6. Do not cover the motor vents as this could lead to motor overheating.

NOTE: In order to avoid breaker tripping, a 20-amp circuit breaker should be used.

Portable Generator:

If using a portable generator, ensure the generator meets the following minimum requirements:

5 KW

120/240 volts

41.7/20.8 amps

Single Phase

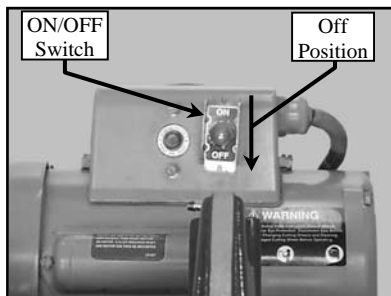

(A)

Ensure the ON/OFF Switch is in the OFF position

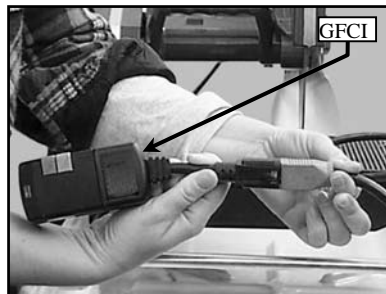

(B)

Plug MK-101 into the GFCI

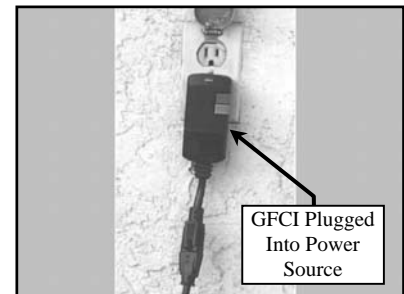

(C)

Plug the GFCI into the Power source *

5. Set Cutting Depth:

⚠CAUTION When loosening the Cutting Head Adjusting Knob, the Cutting Head will pivot down unless held.

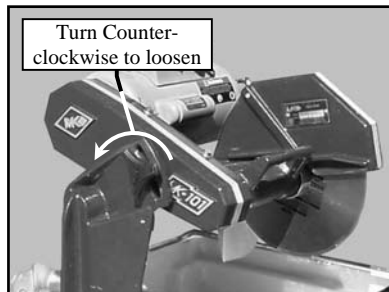

(A)

Loosen Cutting Head Adjusting Knob

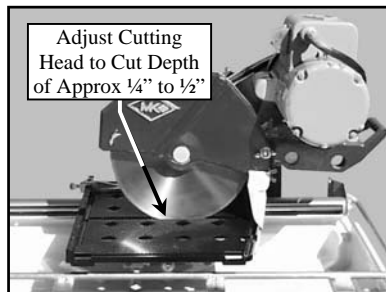

(B)

Set cutting depth approximately 1/4 to 1/2 inch below the surface of the Movable Cutting Table

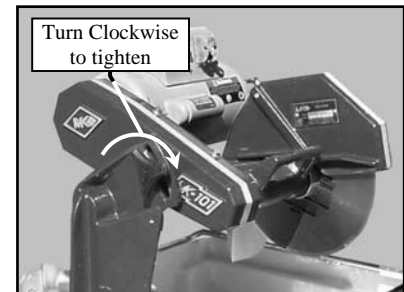

(C)

Ensure the Adjusting Knob is tight

* A GFCI wall socket is the preferred protective device.

SETUP, ADJUSTMENT and OPERATION

ADJUSTMENT and OPERATION:

1. Cutting Straight Edges:

⚠ CAUTION DO NOT FORCE THE TOOL. It will do the job better and safer at the rate for which it was designed.

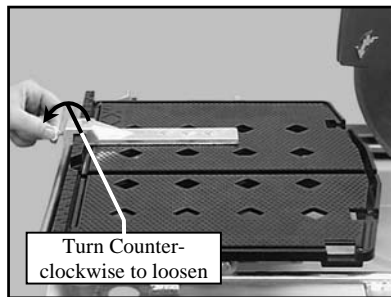

(A)
Loosen the Adjustable Cutting Guide retaining thumbscrew

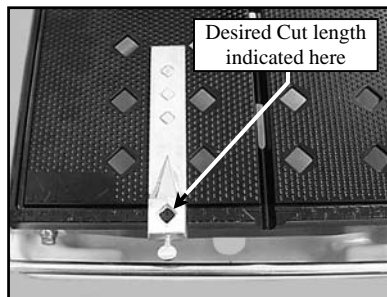

(B)
Position the Adjustable Cutting Guide to desired cut length indicated inside the diamond

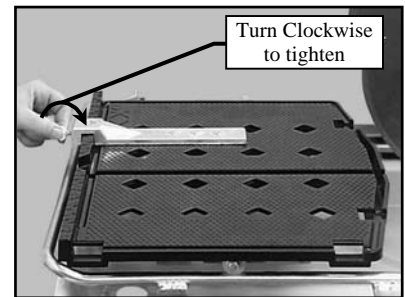

(C)
Tighten the retaining thumbscrew

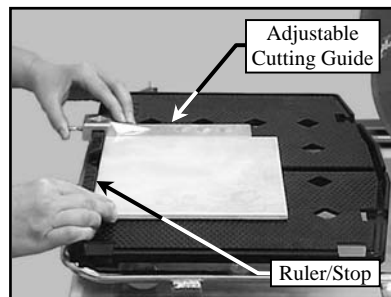

(D)
Place the tile against the Ruler/Stop and Cutting Guide

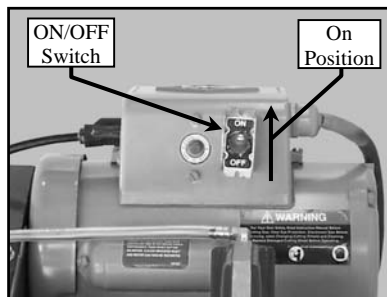

(E)
Turn the motor ON

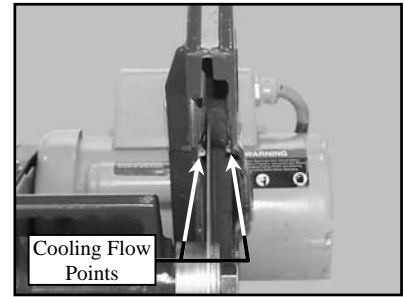

(F)
Verify proper cooling flow on both sides of the blade (See Maintenance Section to increase/decrease flow)

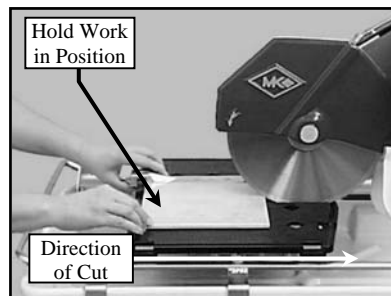

(G)
Perform the cut

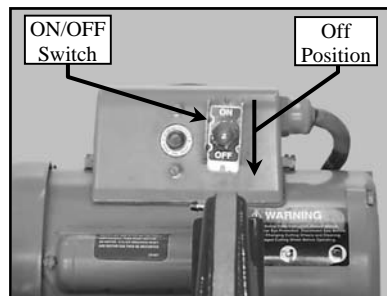

(H)
Turn the motor OFF when work is complete

SETUP, ADJUSTMENT and OPERATION

2. Diagonal Cutting:

NOTE: To cut diagonal, the Dual 45° Flat Angle Guide (MK Diamond Part No. 134557-MK) should be used.

⚠CAUTION DO NOT FORCE THE TOOL. It will do the job better and safer at the rate for which it was designed.

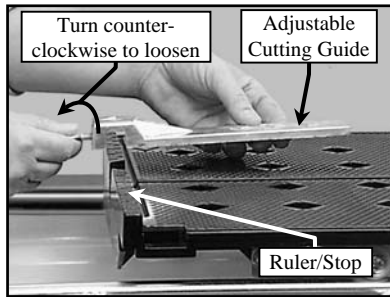

(A)
Remove the Adjustable Cutting Guide

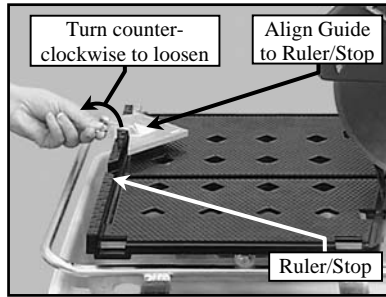

(B)
Place the Dual 45° Flat Angle Guide on the Ruler/Stop

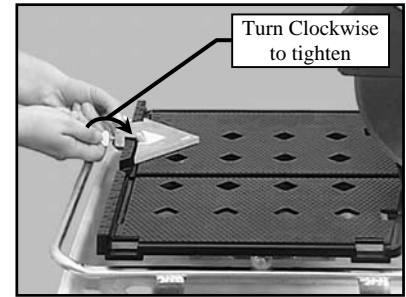

(C)
Position the Dual 45° Flat Angle Guide and tighten the retaining thumbscrew

NOTE: If Cutting the tile in two equal halves, align the tile in the V-notch of the Movable Cutting Table Ruler/Stop.

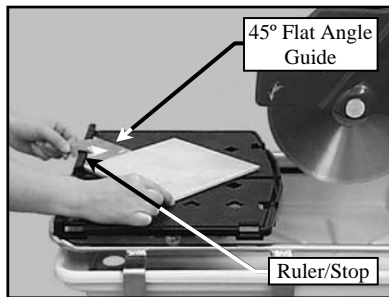

(D)
Position the tile against the Dual 45° Flat Angle Guide and the Ruler/Stop

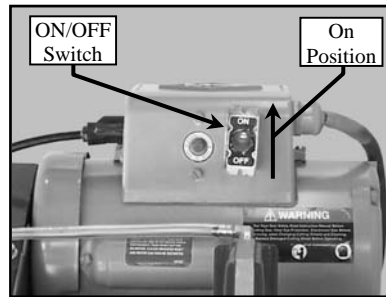

(E)
Turn the motor ON

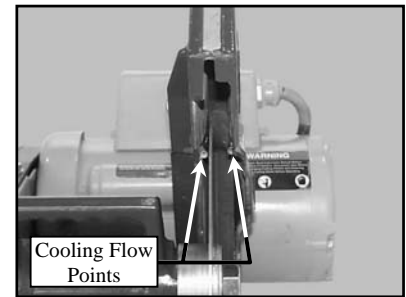

(F)
Verify proper cooling flow on both sides of the blade (See Maintenance Section to increase/decrease flow)

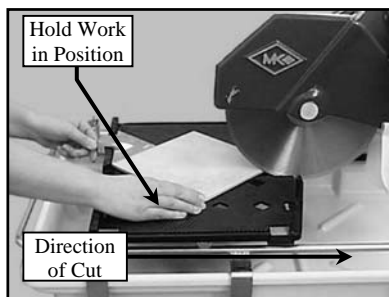

(G)
Perform the cut

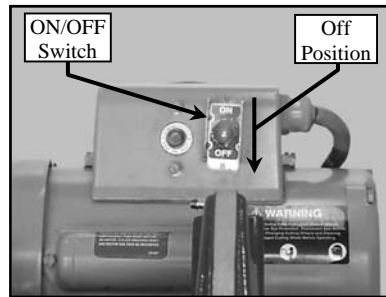

(H)
Turn the motor OFF when work is complete

SETUP, ADJUSTMENT and OPERATION

3. 45° Miter Cutting:

NOTE: To cut 45° Miters, the 45° Bullnose Miter Guide (MK Diamond Part No. 134585-MK) should be used.

⚠CAUTIONDO NOT FORCE THE TOOL. It will do the job better and safer at the rate for which it was designed.

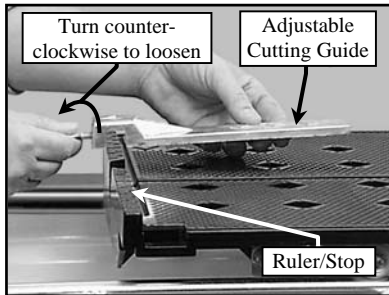

(A)
Remove the Adjustable Cutting Guide

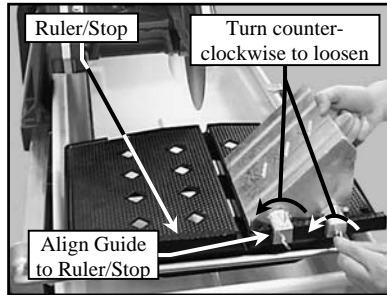

(B)
Place the 45° Bullnose Miter Guide on the Ruler/Stop

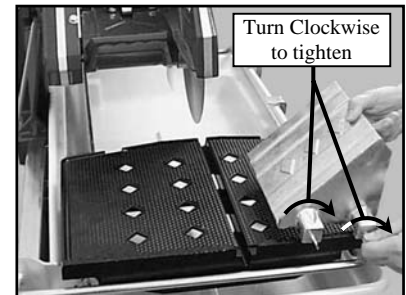

(C)
Position the 45° Bullnose Miter Guide and tighten the retaining thumbscrew

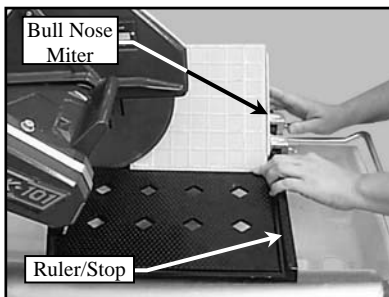

(D)
Position the tile on the 45° Bullnose Miter Guide and the Ruler/Stop

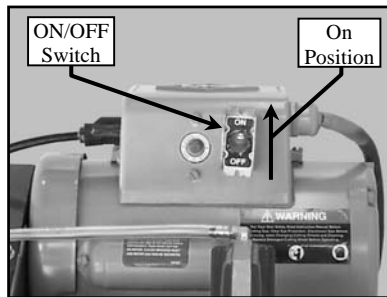

(E)
Turn the motor ON

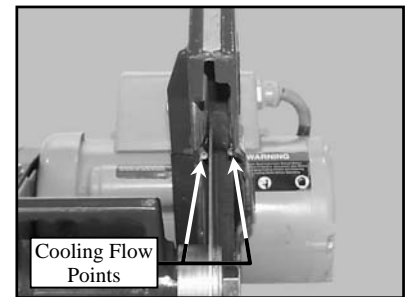

(F)
Verify proper cooling flow on both sides of the blade (See Maintenance Section to increase/decrease flow)

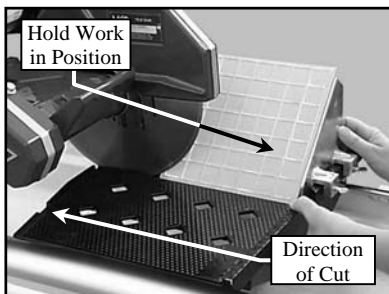

(G)
Perform the cut

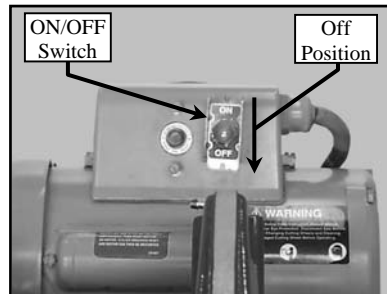

(H)
Turn the motor OFF when work is complete

SETUP, ADJUSTMENT and OPERATION

4. Off-angle Cutting:

NOTE: To cut angles other than 45° angles or Miters, a 90° Protractor (MK Diamond Part No. 134569-MK) should be used.

⚠CAUTIONDO NOT FORCE THE TOOL. It will do the job better and safer at the rate for which it was designed.

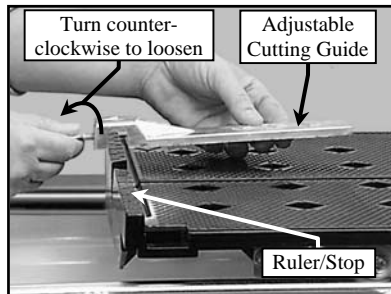

(A)
Remove the Adjustable Cutting Guide

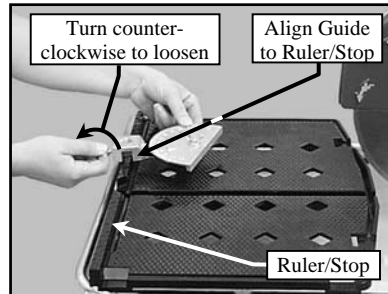

(B)
Place the 90° Protractor on the Ruler/Stop

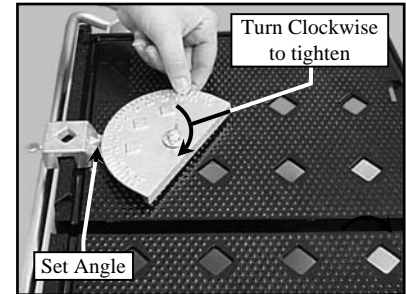

(C)
Set the desired angle and tighten the thumbscrew

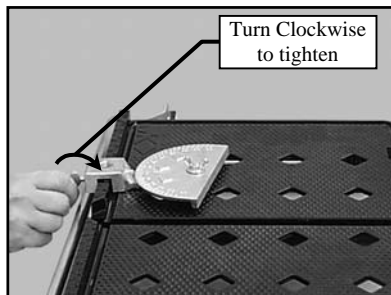

(D)
Position the 90° Protractor and tighten the retaining thumbscrew

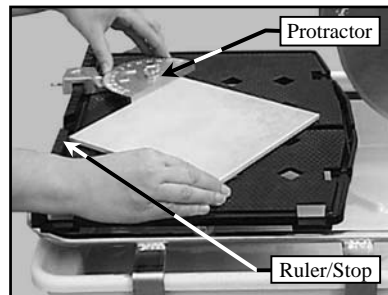

(D)
Position the tile against the 90° Protractor and the Ruler/Stop

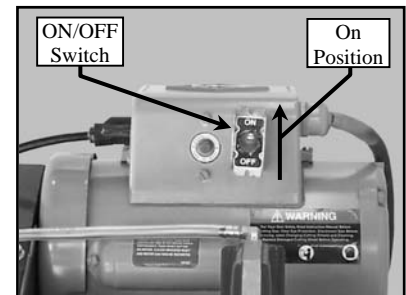

(E)
Turn the motor ON

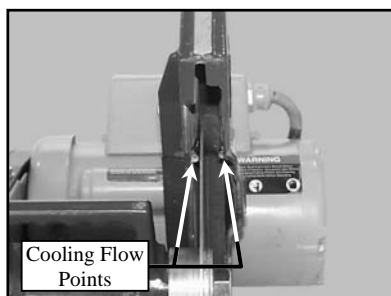

(F)
Verify proper cooling flow on both sides of the blade (See Maintenance Section to increase/decrease flow)

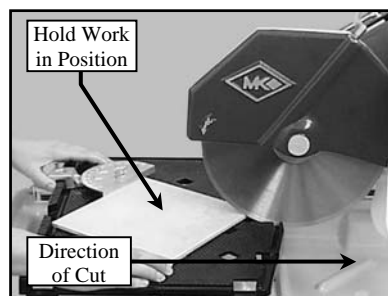

(G)
Perform the cut

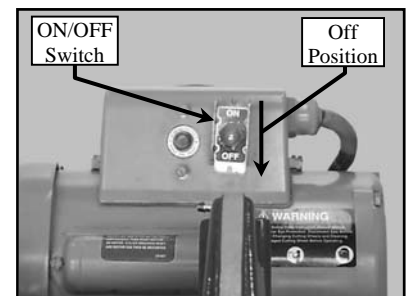

(H)
Turn the motor OFF when work is complete

SETUP, ADJUSTMENT and OPERATION

5. Adjusting the Cutting Head:

⚠CAUTION The Cutting Head is heavy! Care must be used when changing the position of the Cutting Head.

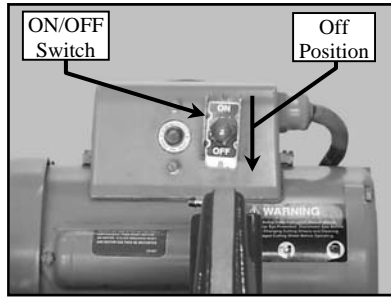

(A)
Ensure the ON/OFF Switch is in the OFF position

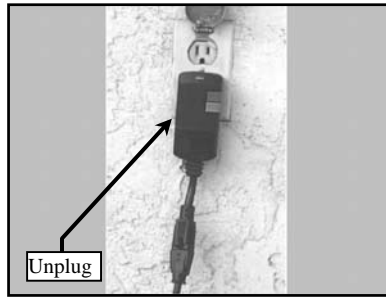

(B)
Unplug the GFCI from the power source*

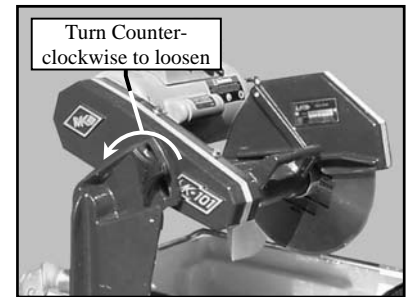

(C)
Remove Adjusting Knob

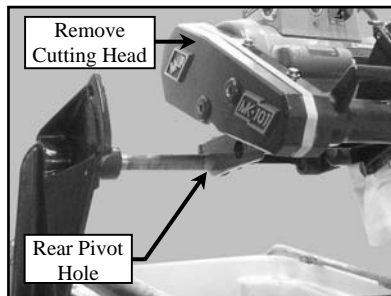

(D)
Remove the Cutting Head from The rear pivot hole

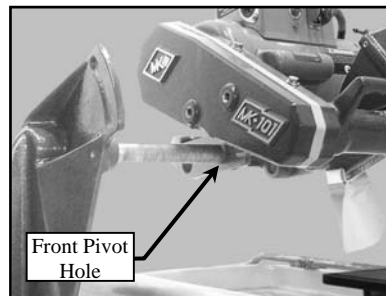

(E)
Install the Cutting Head onto the front pivot hole

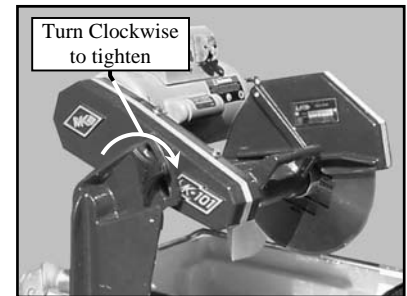

(F)
Install the Adjusting Knob

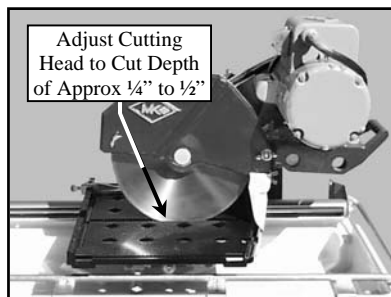

(G)
Set cutting depth approximately 1/4 to 1/2 inch below the surface of the Movable Cutting Table

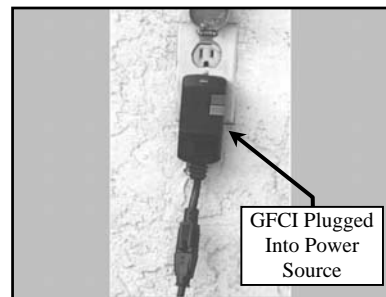

(H)
Plug the GFCI into the power source*

* A GFCI wall socket is the preferred protective device.

SETUP, ADJUSTMENT and OPERATION

6. Adjusting the Post for Maximum Cutting Length:

⚠CAUTION The Cutting Head and Post are heavy! Use care when changing the position of the Cutting Head.

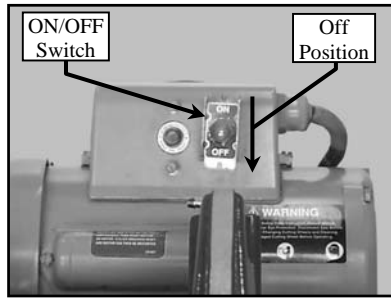

(A)
Ensure the ON/OFF Switch is in the OFF position

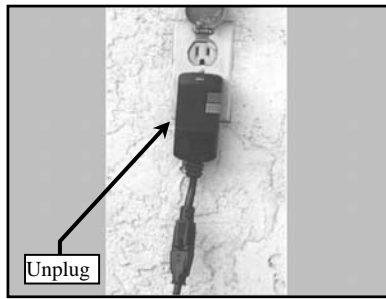

(B)
Unplug the GFCI from the power source*

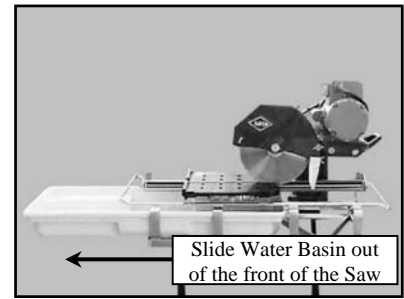

(C)
Remove Water Basin

⚠CAUTION Hold the Post when removing the Post Support Plate.

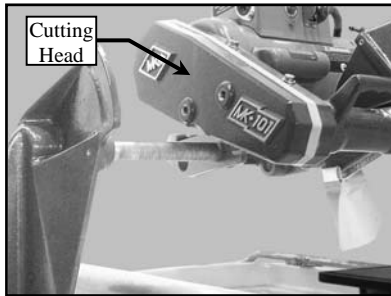

(D)
Remove the Cutting Head (See Adjusting the Cutting Head)

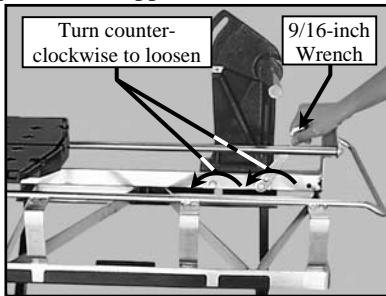

(E)
Loosen the Post Support Plate and retaining bolts

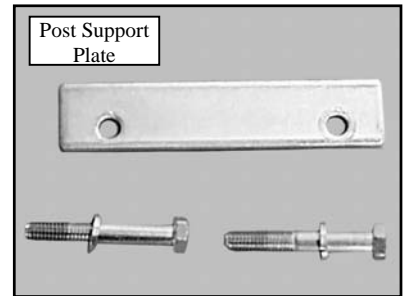

(F)
Remove the Post Support Plate and retaining bolts

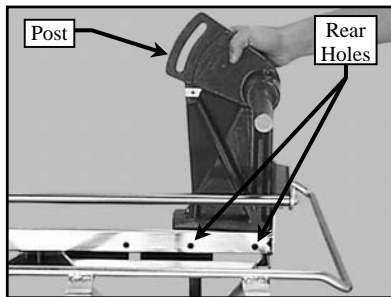

(G)
Relocate the Post to the rear Post retaining holes

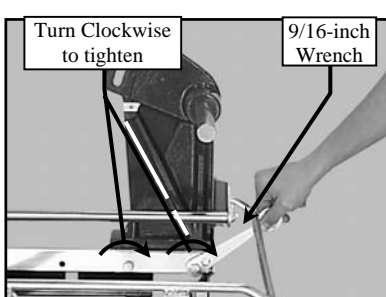

(H)
Install and tighten the Post Support Plate and retaining bolts

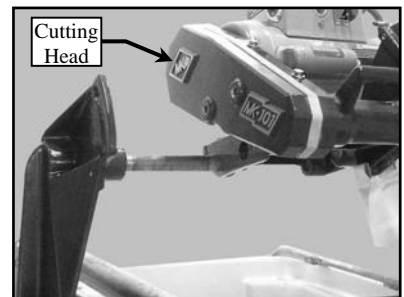

(I)
Install the Cutting Head (See Adjusting the Cutting Head)

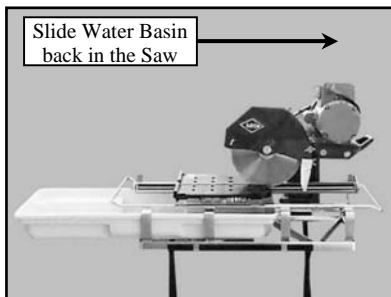

(J)
Install the Water Basin

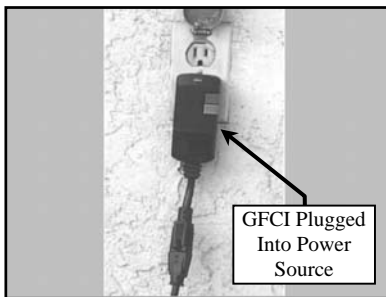

(K)
Plug the GFCI into the power source*

* A GFCI wall socket is the preferred protective device.

SETUP, ADJUSTMENT and OPERATION

7. Cleanup:

- NOTES: 1. If an external water source was used, steps A through C may be skipped.
2. Dispose of waste water in accordance with applicable Federal, State and Local laws.

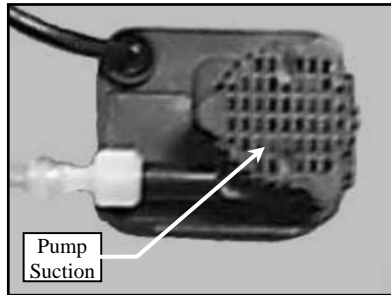

(A)
Clean the Water Pump suction of all debris

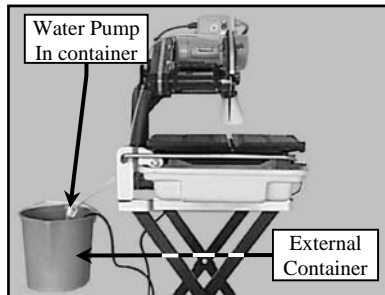

(B)
Place the Water Pump In an external container

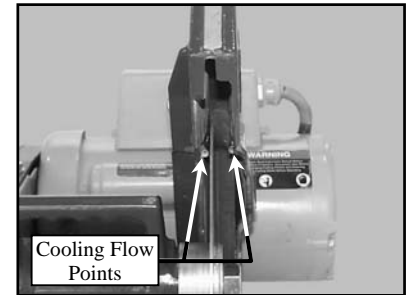

(C)
Run the MK-101 until clear water is seen at the blade cooling ports (Approx. 1 minute)

CAUTION Ensure the saw is disconnected before completing the remainder of the cleanup process.

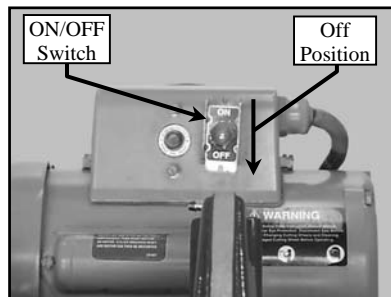

(D)
Ensure the ON/OFF Switch is in the OFF position

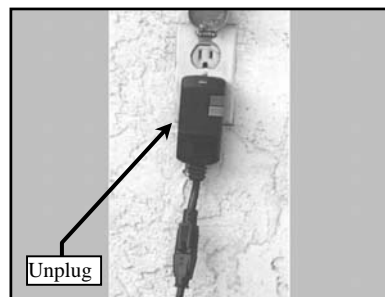

(E)
Unplug the GFCI from the Power source

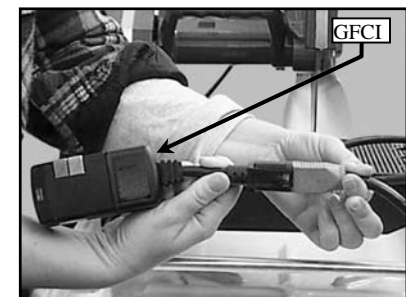

(F)
Unplug MK-101 from the GFCI

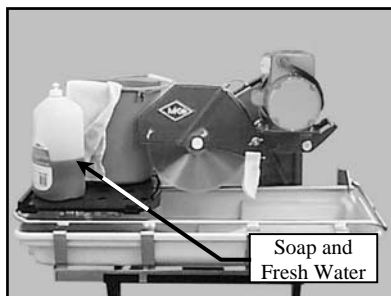

(G)
Clean the MK-101 with soap and clean water

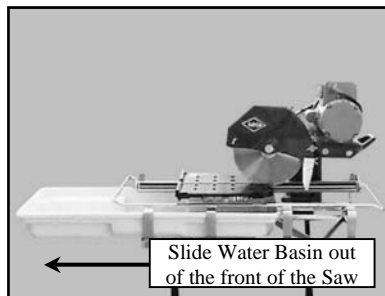

(H)
Remove the Water Basin from the MK-101

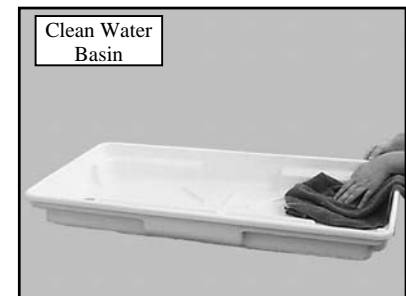

(I)
Clean the Water Basin

* A GFCI wall socket is the preferred protective device.

SETUP, ADJUSTMENT and OPERATION

⚠CAUTION Ensure water is not forced into the motor casing when cleaning.



(J)
Clean the Movable Cutting
Table Guide Bar

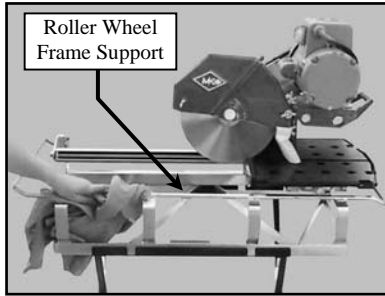

(K)
Clean the Movable Cutting
Table Roller Wheel Frame
Support



(L)
Clean the remainder of the
MK-101

MAINTENANCE AND TROUBLESHOOTING

MAINTENANCE:

1. New Maintenance:

Perform the following after initial purchase and operation of the MK-101.

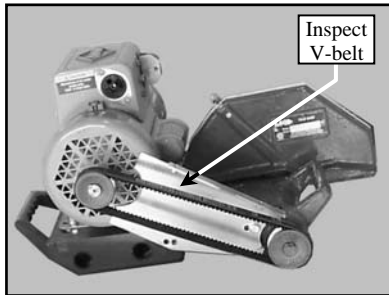

(A)

Check and adjust V-belt tension Following 1st 48 hours of operation (See V-belt Inspection)

2. Maintenance Following Use:

To extend the life of the MK-101, the following procedure should be performed after each use. Lubricate all points listed below with light oils such as, 3 in 1, WD-40, etc.

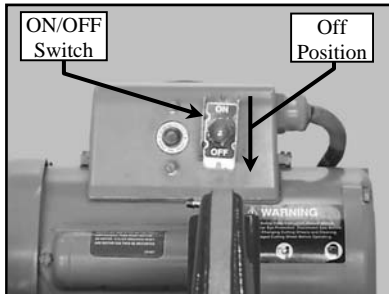

(A)

Ensure the ON/OFF Switch is in the OFF position

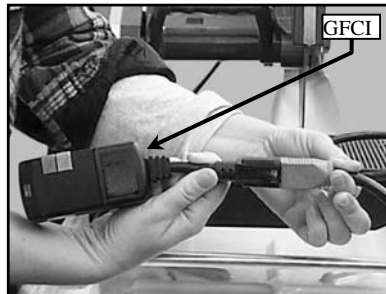

(B)

Unplug MK-101*

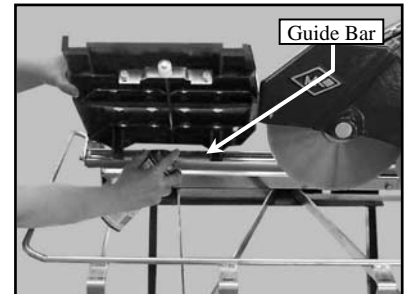

(C)

Lubricate the Guide Bar

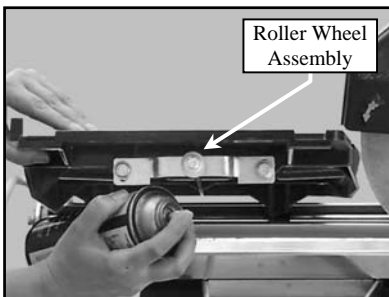

(A)

Lubricate the Roller Wheel Assembly

* A GFCI wall socket is the preferred protective device.

MAINTENANCE AND TROUBLESHOOTING

3. Monthly Maintenance:

The following maintenance should be performed Monthly.

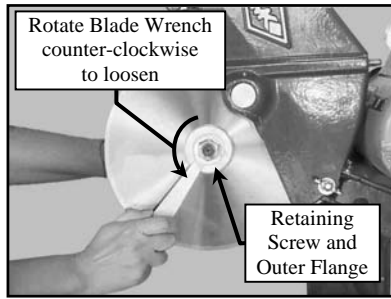

(A)
Remove the Diamond Blade

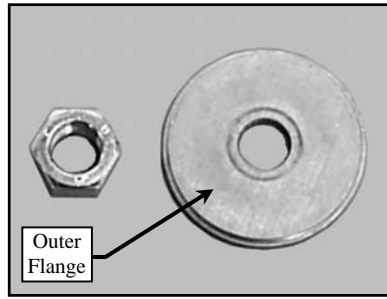

(B)
Lubricate the Outer Flange and Retaining-nut

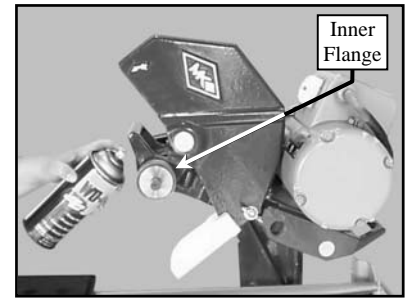

(C)
Lubricate the Inner Flange

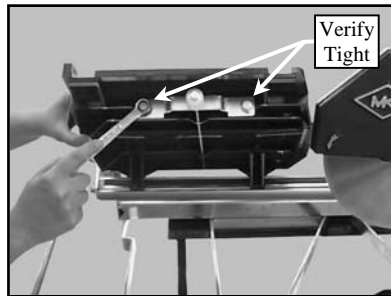

(D)
Verify the Roller Wheel Assembly is tight and in good condition

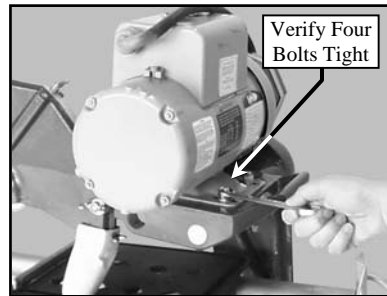

(E)
Verify all motor mounting Bolts are tight

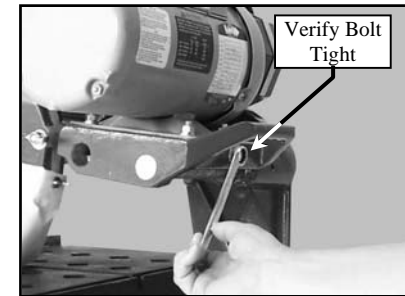

(F)
Verify the Motor Adjustment Strap is tight

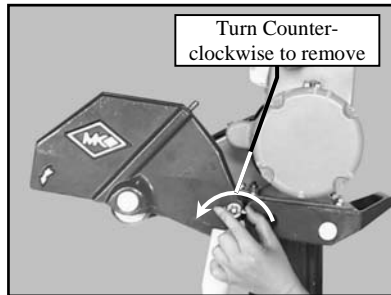

(G)
Remove the Blade Guard

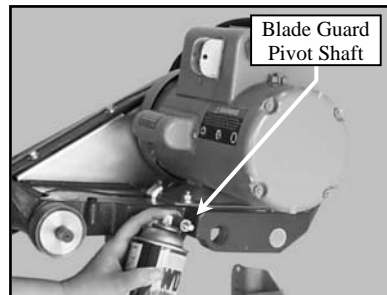

(H)
Lubricate the Blade Guard Pivot Shaft

MAINTENANCE AND TROUBLESHOOTING

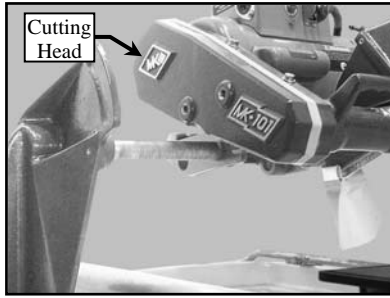

(I)
Remove the Cutting Head (See
Adjusting the Cutting Head)

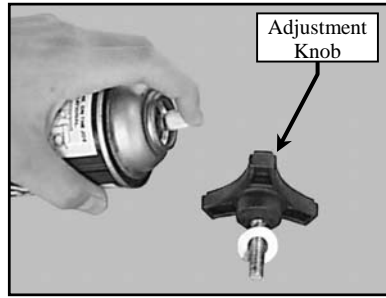

(J)
Lubricate the Cutting Head
Adjustment Knob

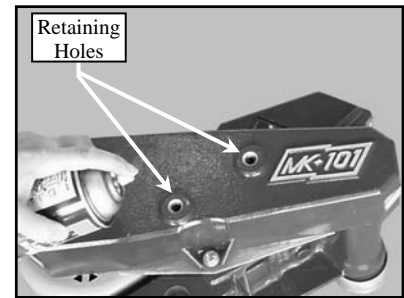

(K)
Lubricate the Cutting Head
Adjustment Knob retaining holes

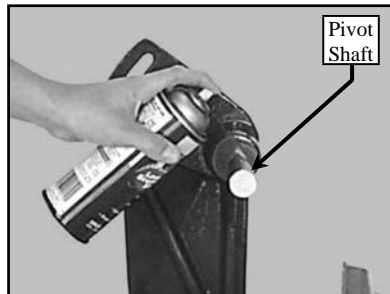

(L)
Lubricate the Cutting Head
Pivot Shaft

4. Flow Adjustment:

NOTE: If flow to the diamond blade requires adjustment, perform the following actions.

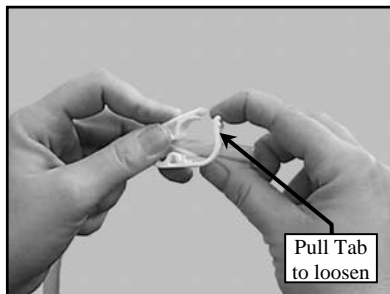

(D)
Increase cooling flow by releasing
the Flow Adjusting Clamp

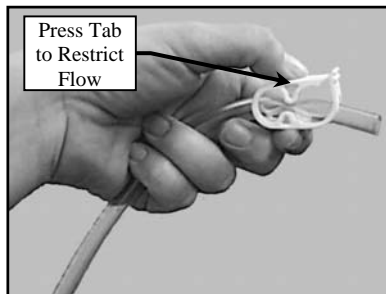

(E)
Reduce cooling flow by
Pressing down on the Flow
Adjusting Clamp

MAINTENANCE AND TROUBLESHOOTING

1. Blade Dressing:

Like most cutting instruments, a diamond blade performs best when it is dressed. Over time and use, diamonds on the outer edge of the blade will become smoothed or “glazed” over. This will reduce grinding efficiency and may cause the blade to “wander” or bend giving the illusion of an alignment problem. When this occurs, the blade will need to be dressed. The diamond blade can be dressed using the MK Dressing Stick (part number 152972) and by following the steps below.



(A)
Setup the MK101 for operation
(See Setup, Adjustment
and Operation)

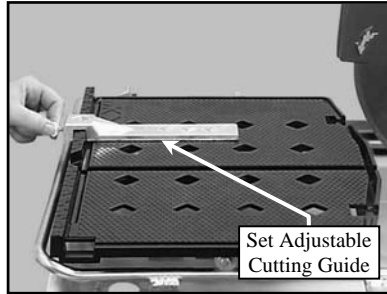

(B)
Set the Adjustable Cutting Guide
to cut a 1/16-strip

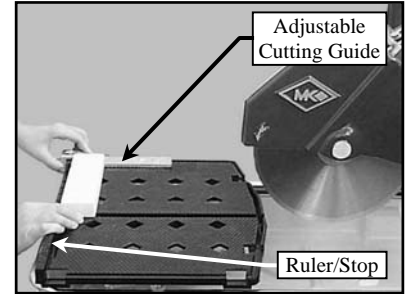

(C)
Position the Dressing Stick

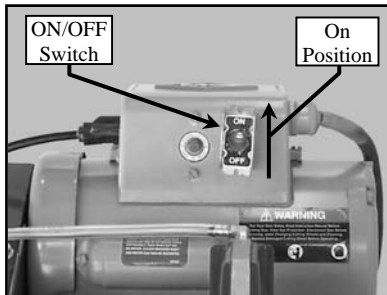

(D)
Turn the motor ON

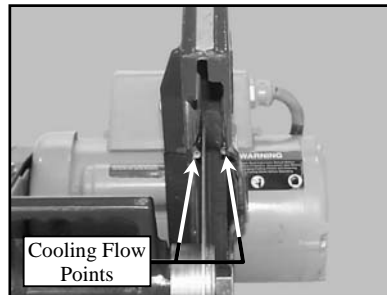

(E)
Verify proper cooling flow on
both sides of the blade (See
Maintenance Section to
increase/decrease flow)

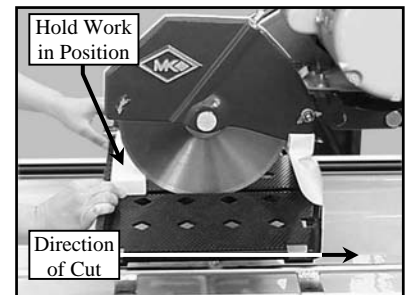

(F)
Cut the Dressing Stick 7 or 8
times to dress the Blade

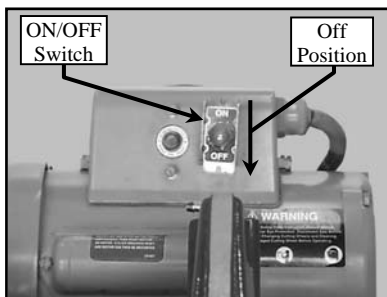

(G)
Ensure the ON/OFF Switch
is in the OFF position

MAINTENANCE AND TROUBLESHOOTING

2. Diamond Blade Change-out:

NOTE: When installing the Retaining Screw, do not "cross-thread" and DO NOT over tighten the screw.

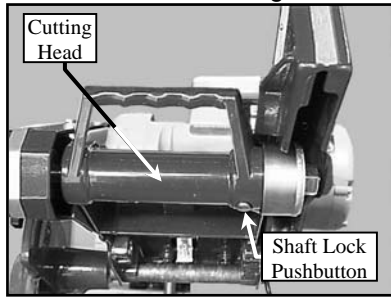

(A)
Locate the Shaft Lock pushbutton on the underside of the Cutting Head

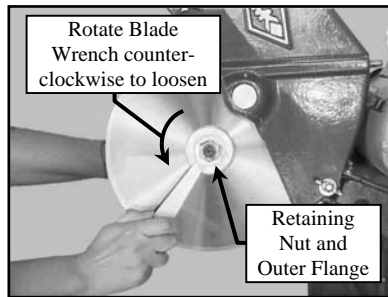

(B)
Remove Retaining Nut and Outer Flange, depress and hold the Shaft Lock pushbutton and loosen

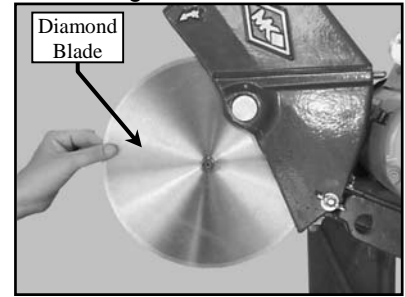

(C)
Remove the Diamond Blade

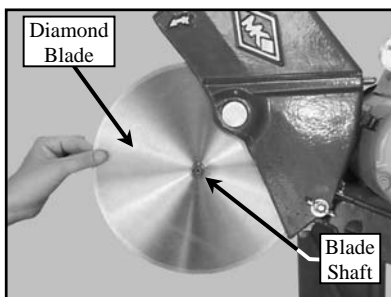

(D)
Install the Diamond Blade onto Blade Shaft

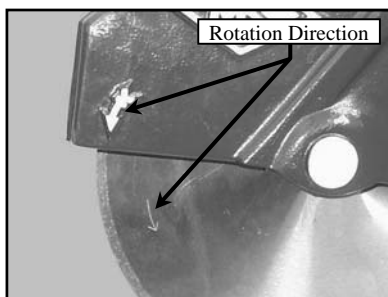

(E)
Verify the Blade is seated on the Blade Shaft and direction of rotation is correct

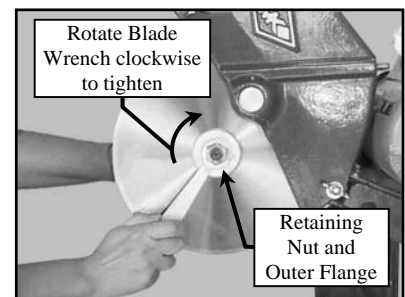

(F)
Install Retaining Nut and Outer Flange, depress and hold the Shaft Lock pushbutton and tighten

3. Cutting Head Stop Installation:

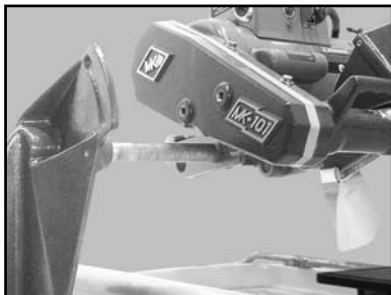

(A)
Remove the Cutting Head
(See Adjusting the Cutting Head)

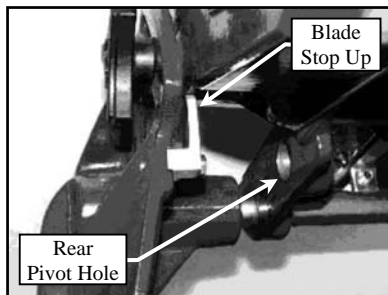

(B)
Install Head Stop UP, when the Cutting Head is installed on the rear Pivot Hole

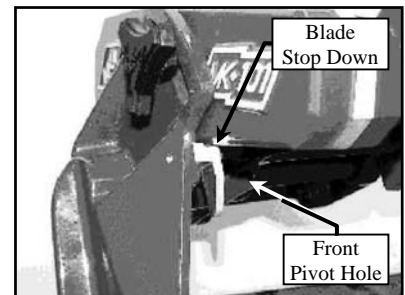

(C)
Install Head Stop DOWN, when the Cutting Head is installed on the forward Pivot Hole



(D)
Reinstall the Cutting Head
(See Adjusting the Cutting Head)

MAINTENANCE AND TROUBLESHOOTING

4. V-Belt Inspection, Adjustment and Replacement:

The MK-101 is designed with a power transmission V-belt. In order to ensure the MK-101 operates at peak efficiency, the V-belt should be inspected monthly, and changed if the V-belt shows damage and/or excessive wear.

NOTE: 1. When a new belt is installed, it should be inspected and re-tensioned after the first forty-eight (48) hours of operation.

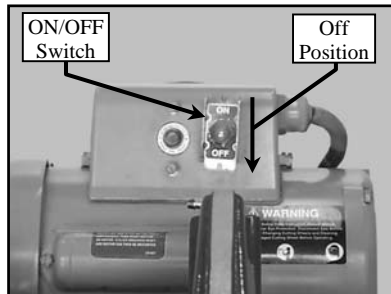

(A)
Ensure the ON/OFF Switch is in the OFF position

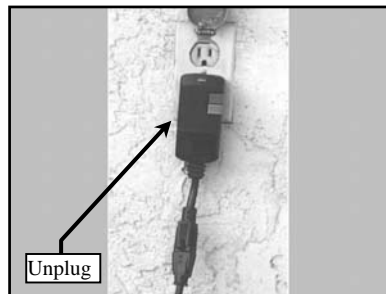

(B)
Unplug the GFCI from the Power source*

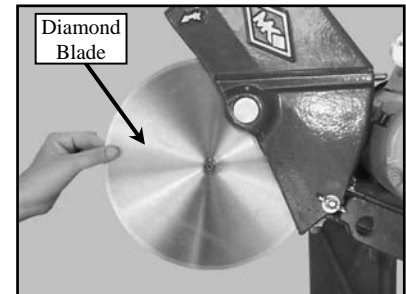

(C)
Remove the Diamond Blade

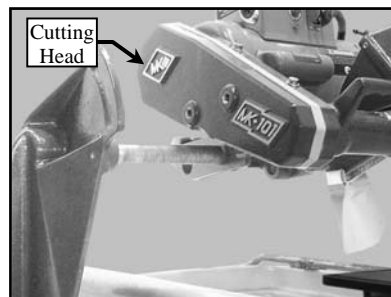

(D)
Remove the Cutting Head (See Adjusting the Cutting Head)

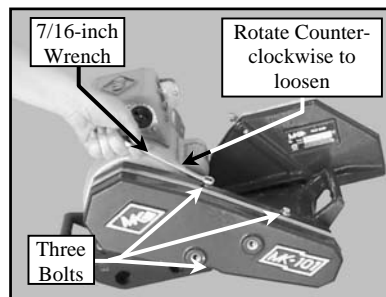

(E)
Remove the Belt Guard

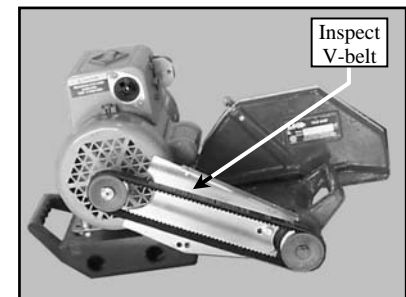

(F)
Inspect the V-belt for cracks, Fraying, separation and wear. Go to step H if replacement required

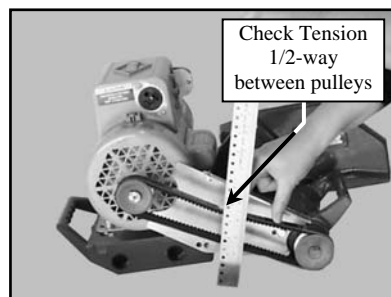

(G)
Check the belt for proper tension if tension is correct, go to step R (proper tension 1/8-inch)

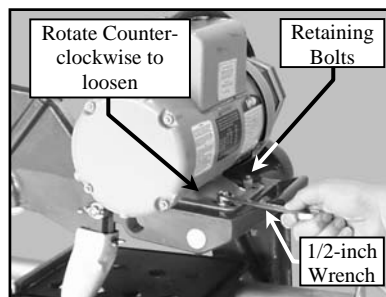

(H)
Loosen the motor mounting bolts, if re-tensioning only go to step N

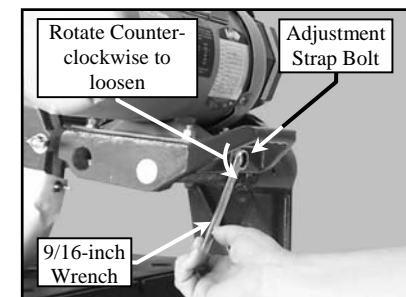

(I)
Loosen the Motor Adjustment Strap

* A GFCI wall socket is the preferred protective device.

MAINTENANCE AND TROUBLESHOOTING

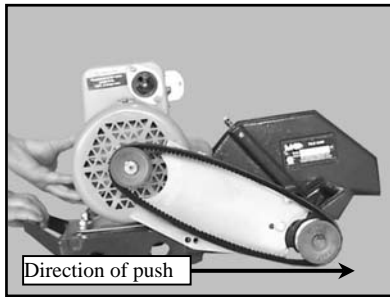

(J)
Push the motor toward the front of the Cutting Head to loosen the V-belt

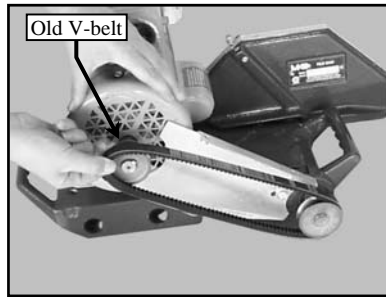

(K)
Remove the V-belt

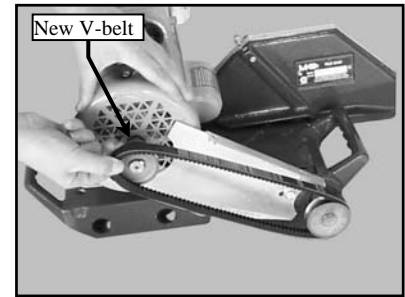

(L)
Install the new V-belt
(MK Diamond Part No. 158194)

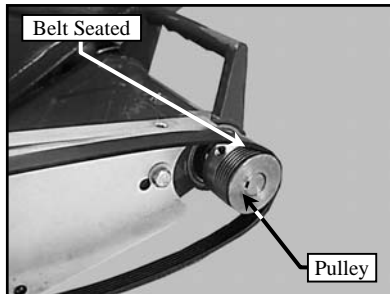

(M)
Verify the V-belt is seated in the grooves of both pulleys

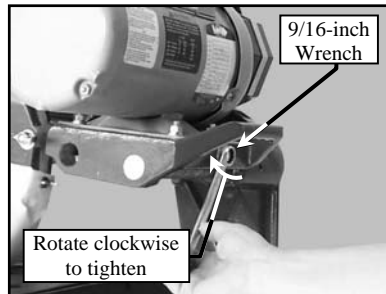

(N)
Tighten the Motor Adjustment Strap to remove slack

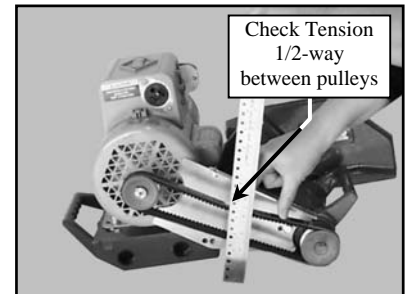

(O)
Check V-belt tension
(proper tension 1/8-inch)

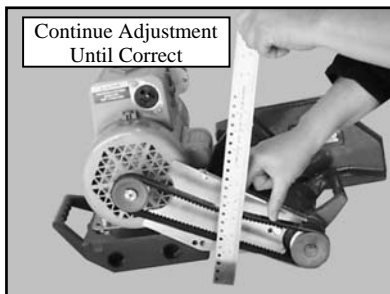

(P)
Repeat steps N and O until proper V-belt tension is achieved

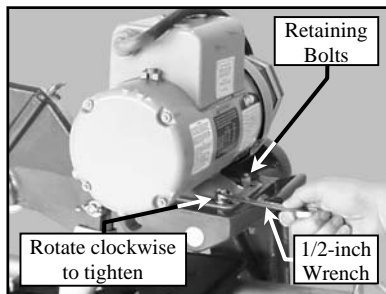

(Q)
Tighten the motor mounting bolts

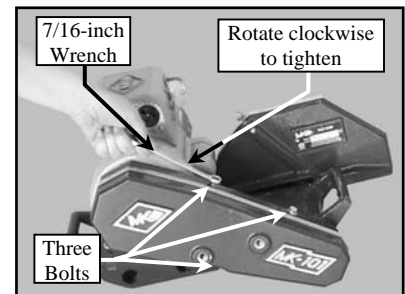

(R)
Install the Belt Guard

MAINTENANCE AND TROUBLESHOOTING

3. Cooling Flow:

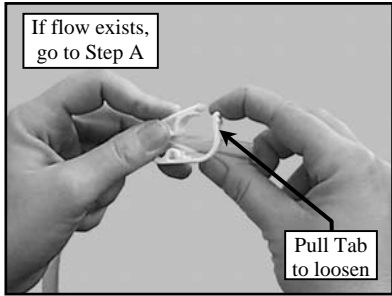

(A)
Verify the cooling flow
Adjusting Clamp is open

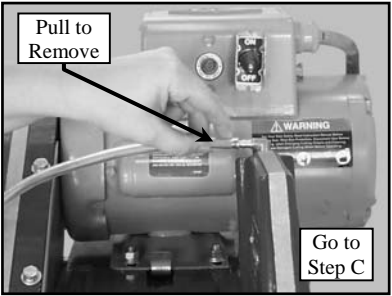

(B)
Remove the Cooling Transfer
Tube from the Blade Guard inlet

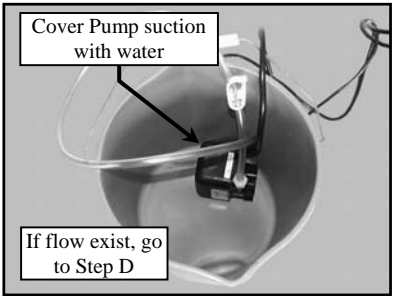

(C)
Place Pump into a bucket of water
and check flow

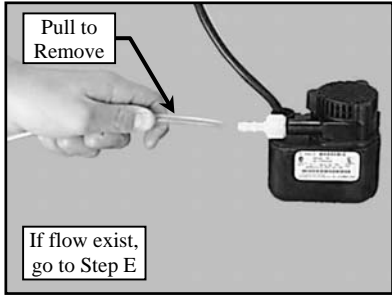

(D)
Remove the Cooling Transfer
Tube and check for flow

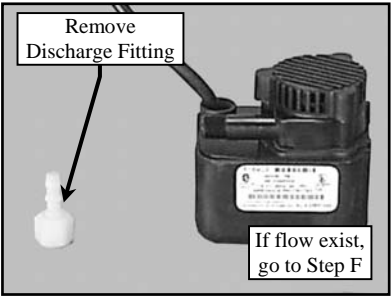

(E)
Remove the Pump Discharge
Fitting and check for flow

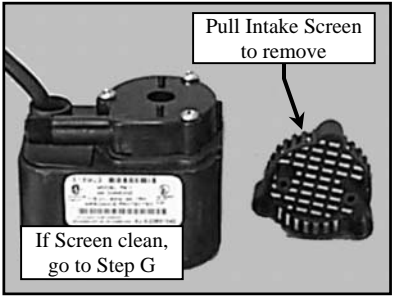

(F)
Remove the Pump Intake
Screen and check for debris –
clean the screen if necessary

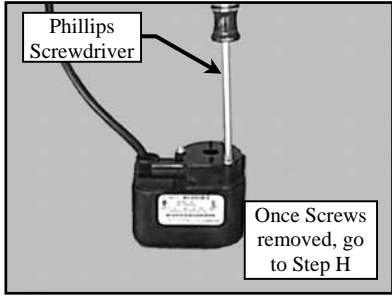

(G)
Remove the 3 Pump Casing
Retaining Screws

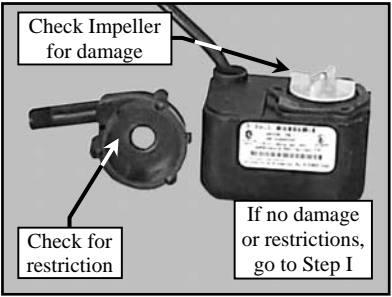

(H)
Remove the Pump Casing and check
for restriction in the casing. Check
the Impeller damage

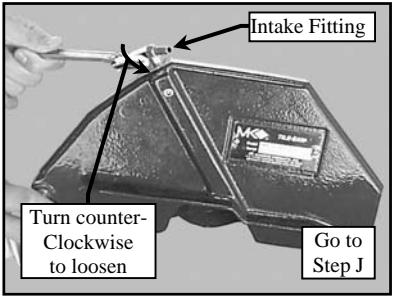

(I)
Remove the Blade Guard
Intake Fitting

MAINTENANCE AND TROUBLESHOOTING

NOTE: "Rodding" cooling channels is performed by inserting a small wire rod through the cooling inlet on top of the Blade Guard and directing the rod out through each of the cooling flow tubes located on the underside of the Blade Guard. The cooling channels should be "rodded" until all ports are free of foreign debris.

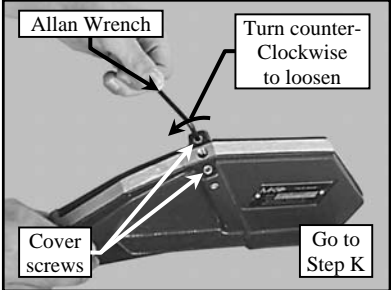

(J)
Remove the Cooling Channel cover screws

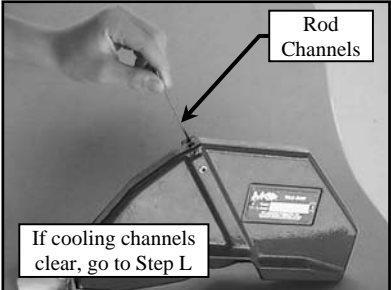

(K)
Rod the Cooling Channels and then recheck flow

**Return to
MK Diamond
for Repair**

(L)
Return to MK Diamond

MAINTENANCE AND TROUBLESHOOTING

4. Blade Stops Turning:

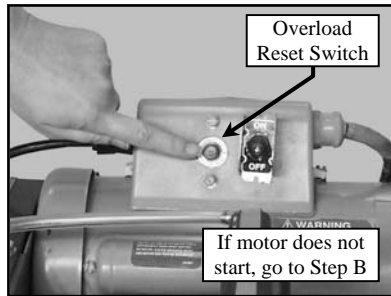

(A)
Allow the motor to cool and depress motor Overload Reset Switch

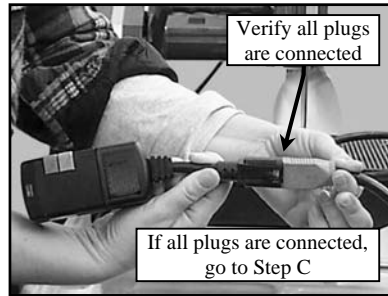

(B)
Verify all plugs are fully installed*

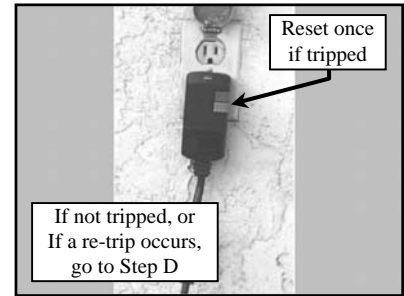

(C)
Check to see if the Ground Fault Circuit Interrupter (GFCI) is tripped*

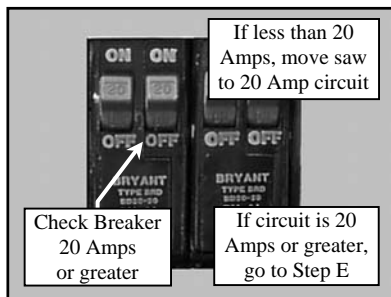

(D)
Verify the circuit breaker is at least 20 amps – if not, move to a 20-amp circuit

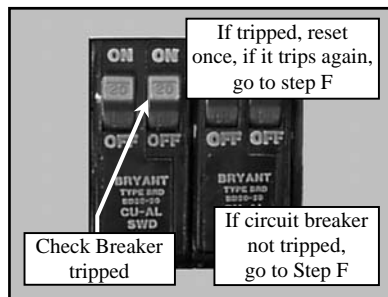

(E)
Verify circuit breaker is not tripped, if it is tripped – reset the circuit breaker once

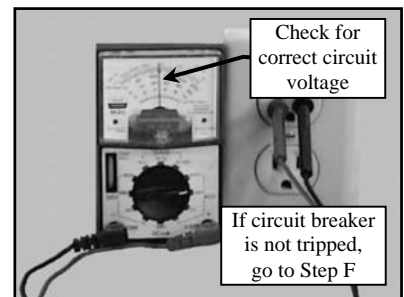

(F)
Check power source voltage is 115V, if it is not 115v – move to another circuit

**Return to
MK Diamond
for Repair**

(G)
Return to MK Diamond

* A GFCI wall socket is the preferred protective device.

EXPLODED VIEW AND PARTS LIST

EXPLODED VIEW:

See Page 42 for
Sub-Assemblies F-J

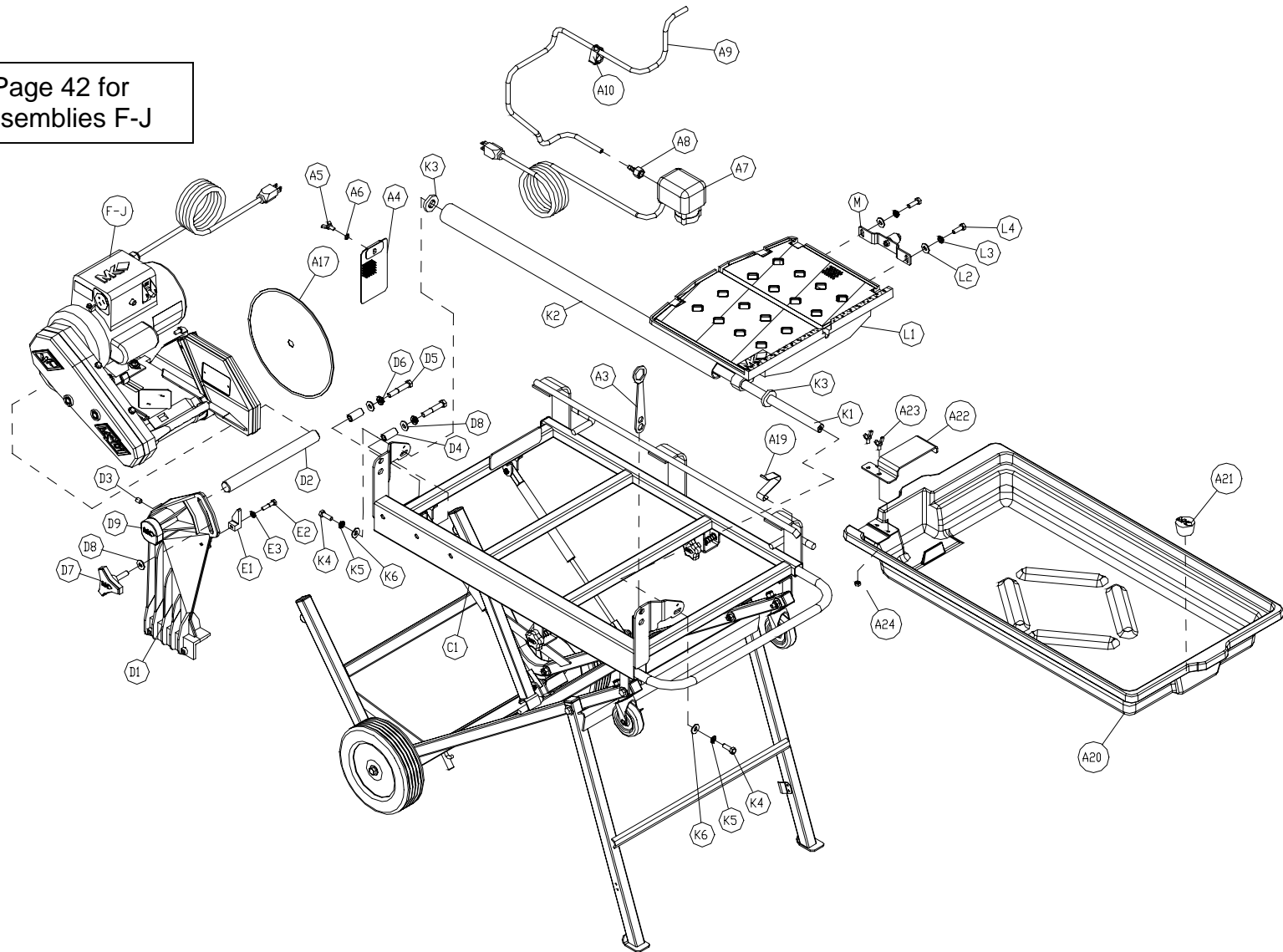

EXPLODED VIEW AND PARTS LIST

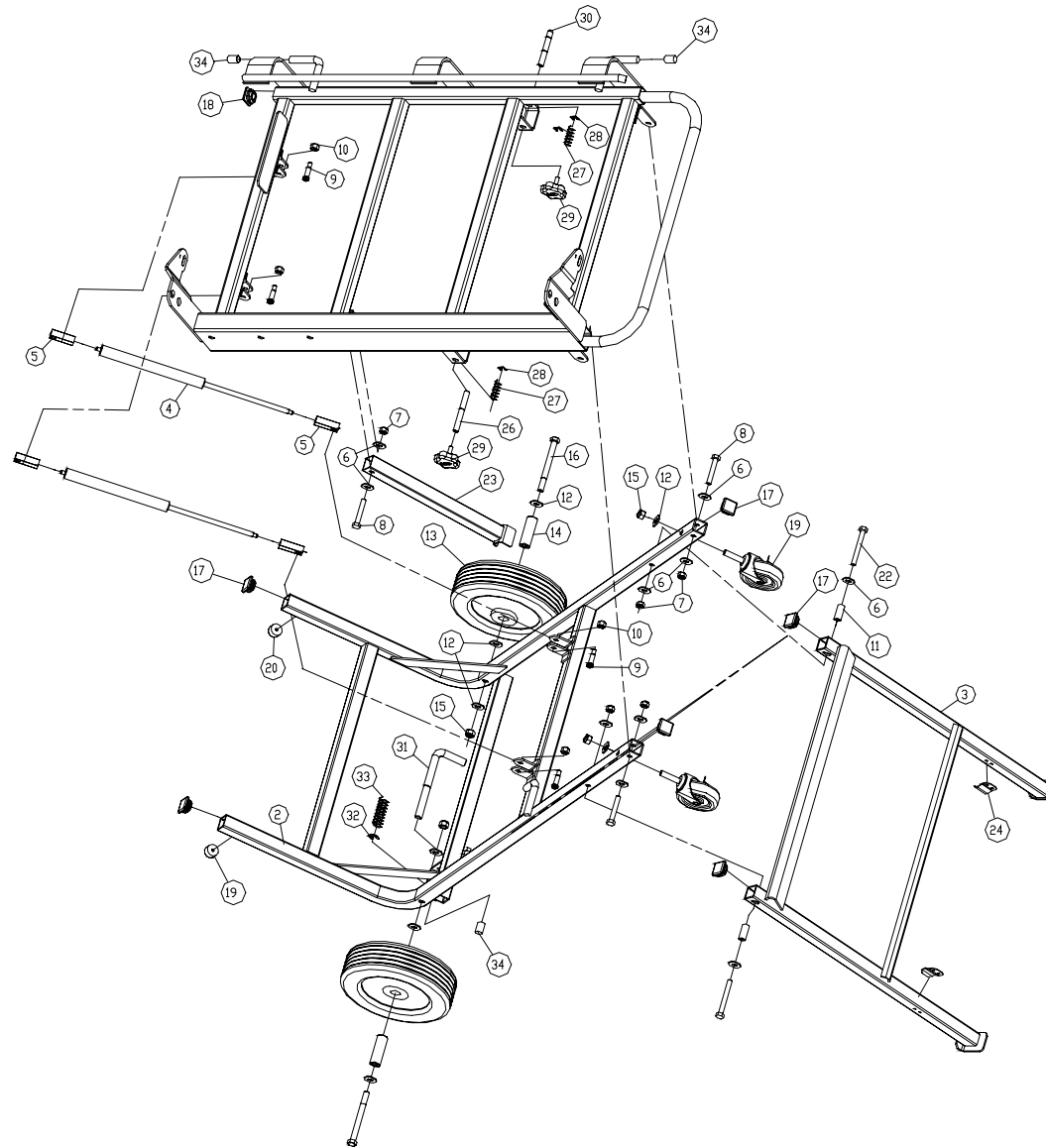

EXPLODED VIEW AND PARTS LIST

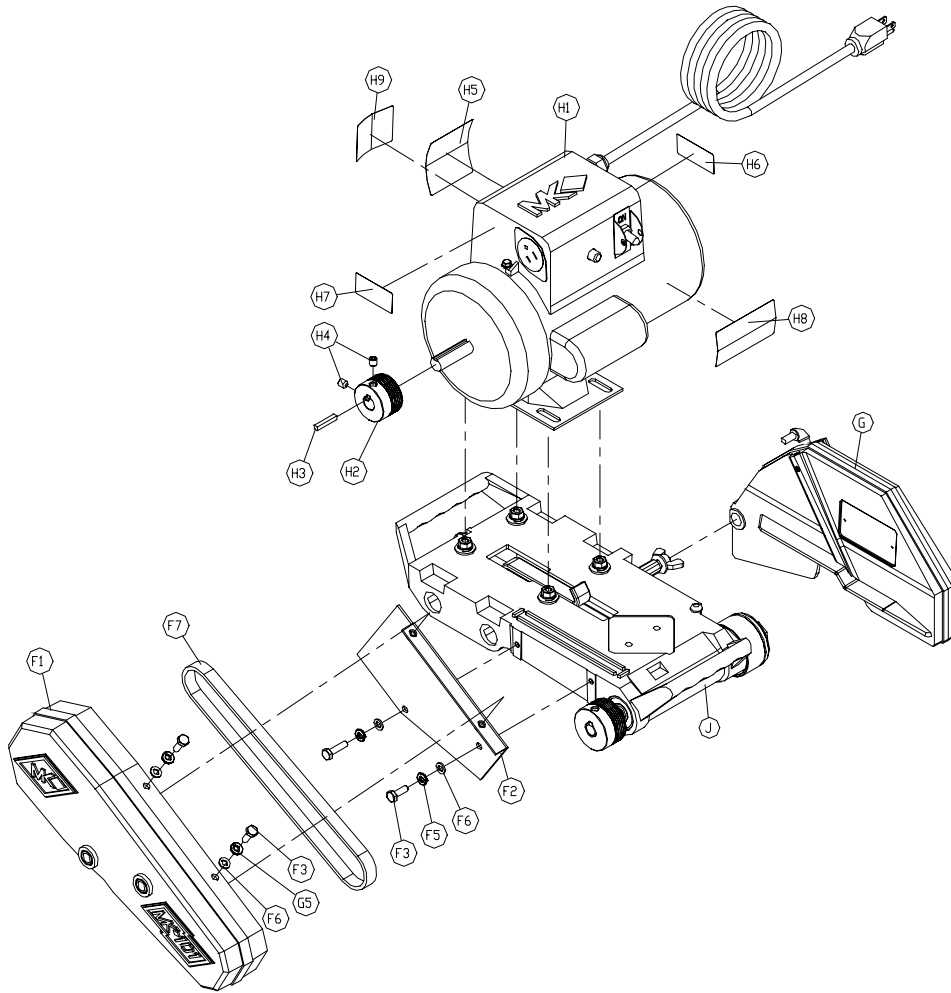

Sub-Assemblies "F" and "G"

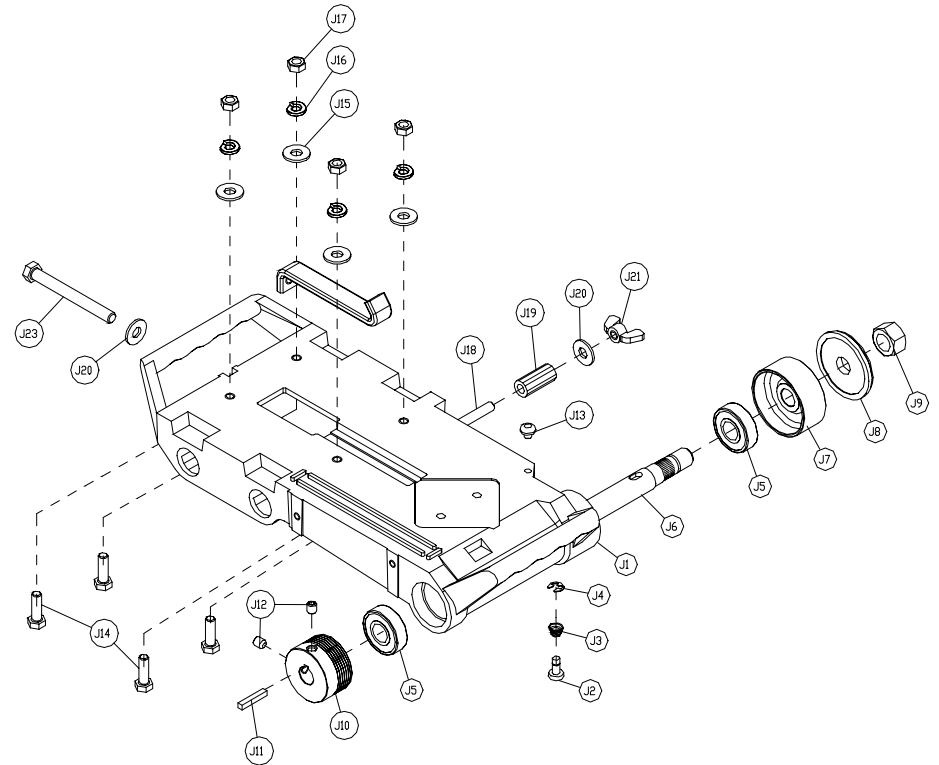

Sub-Assembly "J"

EXPLODED VIEW AND PARTS LIST

PARTS LIST:

Item	Description	Qty	Part #	*Rev
A	Accessories	-	-	-
A1	Carton, Accessory Pack, 10	1	153366	*
A2	Foam, Accessory Pack Carton	1	154022	*
A3	Wrench, 15/16 Closed End	1	134684	*
A4	Guard, Splash	1	160310	*
A5	Wingscrew, 1/4-20 X 1/2	1	151888	
A6	Washer, 1/4 SAE Flat	1	151915	
A7	Pump, Water, G-150A	1	151271	*
A8	Fitting, Plastic, 1/4 FNPT X 1/4 BARB	1	128397	
A9	Hose, Vinyl, 1/4 ID	6'	132951	
A10	Clamp, Flow, 1/4-1/2	1	154394	
A11	Rip Guide, Large Die Cast	1	159751	*
A12	Miter, Large Bullnose	1	153201	*
A13	Owner's Manual, MK-101 Portable Tile Saw	1	162059	*
A14	Card, MK Warranty Registration	1	155037	*
A15	Label, Do Not Return	1	157063	*
A16	Sell Sheet, Tile Accessory	1	156915	*
A17	Blade, MK-100, 10 X 060 X 5/8	1	154380	*
A18	Tag, Serial Number, Blank	1	157500	*
A19	Clip, Table Lock, 30 deg	1	160331-1	*
A20	Pan, Plastic, 101	1	150634	*
A21	Plug, Rubber Drain	1	153439	*
A22	Clamp, Holding , Pump	1	162054	*
A23	Screw, Wing, 1/4-20 x 1/2	2	151888	*
A24	Nut, Hex, 1/4-20	2	151893	*
A25	Sheet, Set Up Instructions (Not shown in Exploded View)	1	162082	
C	Frames	-	-	-
C1	Assembly, Portable Stand	1	160705	*
D	Posts	-	-	-
D1	Post, DC, 101, MK Red	1	158438	*
D2	Shaft, 10.63" Pivot, 101	1	153254	*
D3	Screw, 3/8-16 X 1/2 Socket Head Set	1	153710	*
D4	Spacer, 5/8X.385X1.4	2	160654	*
D5	Screw, 3/8-16 X 2 1/2 Hex Head Cap	2	156030	*
D6	Washer, 3/8 Split Lock	2	150925	*
D7	Knob, 3/8-16 X 1.5 MK Adjustment	1	156770-02	*
D8	Washer, 3/8 SAE Flat	3	150923	*
D9	Plastic Post Cover	1	160157	
E	Stop, Cutting Head			
	Kit, Stop 10" Cutting Head	1	157728-MK	
E1	Stop, 10" Cutting Head	1	157728	*
E2	Screw, 1/4-20 X 1 1/4 Hex Head Cap	1	157145	*
E3	Washer, 1/4 Split Lock	1	152591	*
E4	Sheet, Cutting Head Stop Instruction	1	157728-IS	*
F	Belt Guards	-	-	-
F1	Belt Guard, MK-101	1	158319-01	*
F2	Bracket, Inner Belt Guard, 100/101	1	158611	*
F3	Screw, 1/4-20 x 3/4 Hex Head Cap	3	152370	*
F4	Screw, 1/4-20 x 1 Hex Head Cap	1	152676	*
F5	Washer, 1/4 Split Lock	4	152591	*

EXPLODED VIEW AND PARTS LIST

F6	Washer, 1/4 SAE Flat	4	151915	*
F7	Belt, 260J6 Micro-V	1	158194	*
G	Assembly, Blade Guard	1	152582	
G1	Blade Guard, 101/115	1	153659	*
G2	Tube, Water	2	155389	*
G3	Screw, 5/16-18 X 1/2 Socket Head Set	3	152607	*
G4	Elbow, 1/8 MNPT X 1/4 BARB 90° Brass	1	154652	*
H	Motors	-	-	-
H1	Motor, 1-1/2HP\120V\60Hz	1	160127	*
H2	Pulley, 6J17 X 5/8 Bore	1	158214	*
H3	Key, 3/16 x 3/16 x 1-1/8 Square	1	150344	*
H4	Screw, 5/16-18 X 3/8 Socket Head Set, Cup Point	2	157083	*
H5	Label, Warning most motor..., 2 3/4 X 2 7/16	1	155672	*
H6	Label, Caution, GFCI, 1 X 2 1/8	1	155678	*
H7	Label, Caution, 5 Amp Max., 1 X 2-1/8	1	154822	*
H8	Label, Warning, Read Owner's Manual, 1-3/4 X 3-3/8	1	155806	*
H9	Label, MK Service Info., 2 1/8 X 1-13/16	1	155038	*
J	Assembly, Cutting Head	1	158191	-
J1	Cutting Head, DC, 100/101, MK Red	1	158224	*
J2	Pin, Blade Shaft Lock	1	158200	*
J3	Spring, Blade Guard Lock	1	158201	*
J4	E-Ring, 1/4 Retaining	1	158202	*
J5	Bearing, 17mm X 40mm X 12mm Ball (6203-2NSE)	2	137711	*
J6	Shaft, Blade 100/101	1	158222	*
J7	Flange, 2-3/8 Inner	1	137737	*
J8	Flange, 2-3/8 Outer	1	135830	*
J9	Nut, 5/8-18 Hex	1	135848	*
J10	Pulley, 6J19 X 5/8 Bore	1	158199	*
J11	Key, 3/16 x 3/16 x 1 1/8 Square	1	150344	*
J12	Screw, 5/16-18 X 3/8 Socket Head Set, Cup Point	2	157083	*
J13	Bumper, 1/2 Dia Rubber	1	152674	*
J14	Screw, 5/16-18 X 1 Hex Head Cap	4	151743	*
J15	Washer, 5/16 SAE Flat	4	151754	*
J16	Washer, 5/16 Split Lock	4	151747	*
J17	Nut, 5/16-18 Hex	4	101196	*
J18	Screw, 5/16-18 x 2 1/2 Hex Head Cap, Full Thread	1	151748	*
J19	Pivot, Blade Guard	1	153208	*
J20	Washer, 3/8 SAE Flat	2	150923	*
J21	Wingnut, 5/16-18 Nylock	1	151746	*
J22	Strap, Motor Adjustment	1	152673	*
J23	Screw, 3/8-16 X 3 1/2 Hex Head Full Thread	1	153147	*
K	Guide Bars	-	-	-
K1	Bar, 3/4 X 32 Guide, 101	1	134759	*
K2	Cover, Guide Bar, 120° X 35"	1	158403	*
K3	Spacer, Guide Bar Cover, 101	2	152393	*
K4	Screw, 5/16-18 X 1 Hex Head Cap	2	151743	*
K5	Washer, 5/16 Split Lock	2	151747	*
K6	Washer, 5/16 SAE Flat	2	151754	*
L	Tables	-	-	-
L1	Table, 100/101	1	157660	*
L2	Washer, 5/16 SAE Flat	2	151754	*

EXPLODED VIEW AND PARTS LIST

L3	Washer, 5/16 Split Lock	2	151747	*
L4	Screw, 5/16-18 X 1 Hex Head Cap	2	151743	*
M	Assembly, Roller Wheel	1	151756	-0-
M1	Bracket, Roller Wheel	1	154021	*
M2	Wheel, Roller	1	151799	*
M3	Screw, 1/4-20 X 1 1/2 Hex Head Cap	1	151914	*
M4	Washer, 1/4 SAE Flat	1	151915	*
M5	Nut, 1/4-20 Hex	1	151893	*

PARTS LIST FOR JCS STAND (SHOWN IN PAGE 41):

Item	Description	Qty	MK p/n
-	Assembly, Portable Stand, MK100/101/770EXP	1	160705
1	Weldment, Integrated Frame	1	160690
2	Weldment, Rear Support	1	160693
3	Weldment, Front Support	1	160700
4	Spring, Gas, 600N	2	160696
5	Fitting, End, Gas Spring	4	160695
6	Washer, 5/16 SAE	10	151754
7	Nut, Hex, Nylok, 5/16-18	5	158289
8	Screw, Hex, 5/16-18x2	3	155494
9	Screw, Shoulder, 5/16x3/4	4	160726
10	Nut, Hex, Nylok, 1/4-20	4	159857
11	Spacer, 1/2x5/16x1-1/8	2	160732
12	Washer, 3/8 SAE	8	150923
13	Wheel, 8x2-1/4	2	155986
14	Spacer, 3/4x3/8x2-1/4	2	160728
15	Nut, Hex, Nylok, 3/8-16	4	152505
16	Screw, Hex Hd, 3/8-16x4	2	153531
17	Plug, Plastic, 1 SQ., 10-14 Ga	6	160727-2
18	Plug, Plastic, 1 SQ., 14-20 Ga	1	160727-1
19	Caster, Swivel, 3" w/ 3/8-16 Stem	2	160735
20	Bumper, Rubber	2	159855
21	Rivet, Dome Style, 3/16 Dia x.251-.375 Grip	2	160729-3
22	Screw, Hex Hd, 5/16-18x2-3/4	2	152520
23	Weldment, Vertical Support	1	160934
24	Plate, Spring	1	160694
25	Rivet, Dome Style, 5/32 Dia x.063-.125 Grip	4	161226-1
26	Pin, Locking	1	160936
27	Spring, 1/2x.04x1.75	1	160697
28	Ring, Retaining, 3/8x.035	1	161171
29	Knob, Plastic	1	159428-1
30	Pin, Frame Locking	1	162055
31	Pin, Wheel Locking	1	162051
32	Ring, Retaining, 1/2x.042	1	162053
33	Spring, .600x.045x2.25	1	162052
34	Cap, Vinyl, 1/2-9/16x3/4	3	162057

THEORY

THEORY OF DIAMOND BLADES:

Diamond blades do not really cut; they grind the material through friction. Diamond crystals, often visible at the leading edge and sides of the rim/segment, remove material by scratching out particles of hard, dense materials, or by knocking out larger particles of loosely bonded abrasive material. This process eventually cracks or fractures the diamond particle, breaking it down into smaller pieces. As a result, a diamond blade for cutting soft, abrasive material must have a hard metal matrix composition to resist this erosion long enough for the exposed diamonds to be properly utilized. Conversely, a blade for cutting a hard, non-abrasive material must have a soft bond to ensure that it will erode and expose the diamonds embedded in the matrix. These simple principles are the foundation of “controlled bond erosion”.



Types of Cutting:

There are two basic types of cutting-Dry or Wet. The choice of which type of blade to use depends on:

- The requirements of the job
- The machine/tool utilizing the diamond blade
- The preference of the operator







In the case of DRY cutting, the overwhelming popularity and quantity of hand-held saws and the flexible nature of MK Diamond blades to professionally handle most ceramic, masonry, stone and concrete materials, make the DRY cutting blade a very attractive tool. When using a DRY blade, the user must be aware of distinct operating practices to ensure optimum performance. DRY cutting blades require sufficient airflow about the blade to prevent overheating of the steel core. This is best accomplished by shallow, intermittent cuts of the material with periods of “free-spinning” (for several seconds) between each cut, to maximize the cooling process.

For WET cutting applications, MK has the exact blade to compliment both the material to be cut and the wet cutting machine to be used. During cutting operations, liberal amounts of water act as a coolant to support the cutting effectiveness and longevity of the WET blade. Additionally, using water adds to the overall safety of cutting operations by keeping the dust signature down.

Know All You Can About the Material You Wish to Cut

ACCESSORIES

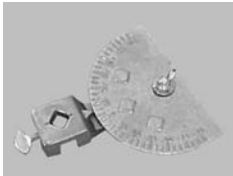
ACCESSORIES:

ITEM	NUMBER	DESCRIPTION	
1.	137166	MK-200, 10 x 5/8 Arbor	
2.	128074	MK-215, 10 x 5/8 Arbor	
3.	153252	MK-315, 10 x 5/8 Arbor	
4.	134577	Dual 45° Flat Angle Guide	
6.	134569	90° Protractor	
7.	152792	Dressing Stone	
8.	152610	Ground Fault Circuit Interrupter	

ORDERING and RETURN INFORMATION

ORDERING INFORMATION:

You may order MK Diamond products through your local MK Diamond distributor or, you may order direct from MK Diamond.

NOTE: There is a \$25.00 minimum order when ordering direct from MK Diamond. All purchases must be made using VISA or MasterCard.

When ordering direct from MK Diamond, please have the following information ready before calling:

- The Model Number of the saw
- The Serial Number of the saw
- Where the saw was purchased and when
- The Part Number for the part(s) being ordered
- The Part Description for the part(s) being ordered

All parts may be ordered by calling toll free to – **800 421-5830** or **310 539-5221** and asking for Customer Service. For technical questions, call – **800 474-5594**.

RETURN MATERIALS POLICY:

To expedite the service relative to the return of a product purchased through MK Diamond, please observe the following:

NOTE: When returning all items, they must have been purchased within the previous twelve (12) months.

- Have the Model Number of the saw
- Have the Serial Number of the saw
- Have the location of where the saw was purchased
- Have the date when the saw was purchased
- Contact Customer Service for approval to return the item(s)
- Obtain a Returned Goods Number (RGA) authorizing the return
- Follow the packaging instructions in the following section
- Ensure your item(s) are prepaid to the destination

For returned items, call toll free to – **800 421-5830** or **310 539-5221** and ask for Customer Service. For technical questions, call – **800 474-5594** or **310 257-2845**.

PACKAGING INSTRUCTIONS:

- Remove the Blade guard and Support Angle Assembly
- Dry the saw before shipping
- When packing, include the following: MK-101, Diamond Blade, Blade guard and Support Angle Assembly and Adjustable Cutting Guide (Other Accessories are not required)
- Package the unit in its original container or one of comparable size (do not ship the unit partially exposed)
- Ensure all parts are secured in the packaging to prevent moving

AUTHORIZED SERVICE CENTERS:

For quicker repair time, you may contact MK Diamond Customer Service, toll free, at – **800 421-5830** or **310 539-5221** for the Authorized Service Center closest to you. For technical questions, call – **800 474-5594**.

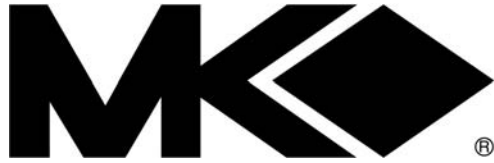

MK-101 w/JCS Stand

TILE SAW OWNER'S MANUAL & OPERATING INSTRUCTIONS

CALIFORNIA PROPOSITION 65 MESSAGE:

⚠WARNING

Some dust created by power sanding, sawing, grinding, drilling, and other construction activities contain chemicals known [to the State of California] to cause cancer, birth defects or other reproductive harm. Some examples of these chemicals are:

- Lead, from lead-based paints
- Crystalline silica, from bricks and cement and other masonry products and
- Arsenic and chromium, from chemically treated lumber

Your risk from these exposures varies depending on how often you do this type of work. To reduce your exposure to these chemicals, work in a well-ventilated area, and work with approved safety equipment, such as those dust masks that are specially designed to filter out microscopic particles.

MK DIAMOND PRODUCTS, INC
1315 STORM PARKWAY, TORRANCE, CA 90509-2803
310 539 5158