



MK-100 SERIES

**TILE SAW
OWNER'S MANUAL &
OPERATING INSTRUCTIONS**



CAUTION:
Read all safety and
operating instructions
before using this
equipment

Enter the Serial Number of your new saw in the
space below. The Serial Number is located on the
left side of the blade guard.

SERIAL NUMBER:

NOTE:

For your (1) one year warranty to be effective,
complete the warranty card (including the Serial
Number and mail it in as soon as possible.

INTRODUCTION

We at MK Diamond want to congratulate you on selecting the MK-100 Tile Saw. We are certain that you will be pleased with your purchase. MK Diamond takes pride in producing the finest products in the industry.

Operated correctly, your MK-100 should provide you with years of quality service. In order to help you, we have included this manual. This owners manual contains information necessary to operate and maintain your MK-100 safely and correctly. Please take a few minutes to familiarize yourself with the MK-100 by reading and reviewing this manual.

If you should have questions concerning your MK-100, please feel free to call our friendly customer service department at: 800 421-5830

Regards,

MK Diamond

TABLE OF CONTENTS

	Page
SAFETY:	4
Safety Messages	4
Damage Prevention Message	4
General Safety Precautions and Hazard Symbols	4
California Proposition 65 Message	6
Electrical Requirements and Grounding Instructions	7
Safety Label Locations	9
Tile Saw Specific Warnings	9
Product Specifications	10
UNPACKING, TRANSPORT, UNIVERSAL STAND, and ASSEMBLY	
Unpacking	11
Contents	11
Transport	11
Universal Stand	12
Assembly	13
SETUP, ADJUSTMENT AND OPERATION	
Setup	15
Adjustment and Operation	18
Cleanup	24
MAINTENANCE AND TROUBLESHOOTING	
Maintenance	26
Troubleshooting	29
EXPLODED VIEW AND PARTS LIST	
Exploded View	37
Parts List	38
THEORY	
Theory of Diamond Saws	41
ACCESSORIES	
Accessories	42
ORDERING and RETURN INSTRUCTIONS	
Ordering Information	43
Return Material Policy	43
Packaging Instructions	43
Authorized Service Centers	43

SAFETY

Read and follow all safety, operating and maintenance instructions. Failure to read and follow these instructions could result in injury or death to you or others. Failure to read and follow these instructions could also result in damage and/or reduced equipment life.

SAFETY MESSAGES:

Safety messages inform the user about potential hazards that could lead to injury, death and/or equipment damage. Each safety message will be preceded by one of the following (3) three words that identify the severity of the message.

⚠ DANGER

Not following instructions **WILL** lead to **DEATH** or **SERIOUS INJURY**

⚠ WARNING

Not following instructions **COULD** lead to **DEATH** or **SERIOUS INJURY**

⚠ CAUTION

Not following instructions **CAN** lead to injury

DAMAGE PREVENTION AND INFORMATION MESSAGES:

A Damage Prevention Message is to inform the user of important information and/or instructions that could lead to equipment or other property damage if not followed. Information Messages convey information that pertains to the equipment being used. Each message will be preceded by the word NOTE, as in the example below.

NOTE:

Equipment and/or property damage may result if these instructions are not followed.

GENERAL SAFETY PRECAUTIONS AND HAZARD SYMBOLS:

In order to prevent injury, the following safety precautions and symbols should be followed at all times!

Safety Precautions:

KEEP GUARDS IN PLACE.



In order to prevent injury, keep guards in place and in working order at all times.

REMOVE ADJUSTING KEYS AND WRENCHES.

Form a habit of checking to see that keys and adjusting wrenches are removed from the power tool before it is turned on.

KEEP WORK AREA CLEAN.

Cluttered work areas and benches invite accidents.

DO NOT USE IN DANGEROUS ENVIRONMENTS.

Do not use power tools in damp or wet locations nor expose them to rain. Always keep the work area well lighted.

KEEP CHILDREN AWAY.

All visitors and children should be kept a safe distance from work area.

MAKE THE WORKSHOP KID PROOF.

Make the workshops kid proof by using padlocks, master switches or by removing starter keys.

DO NOT FORCE THE TOOL.

A power tool will do a job better and safer operating at the rate for which it was designed.

USE THE RIGHT TOOL.

Do not force a tool or an attachment, to do a job that it was not designed to do.

SAFETY

USE THE PROPER EXTENSION CORD.

If using an extension cord make sure it is in good condition first. When using an extension cord, be sure to use one heavy enough to carry the current your product will draw. An undersized cord will cause a drop in line voltage that will result in a loss of power and overheating. TABLE 1, Page 7 shows the correct AWG size to use depending on cord length and nameplate ampere rating. If in doubt, use the next heavier gage. The smaller the gage number, the heavier the cord.

WEAR PROPER APPAREL.

Do not wear loose clothing, gloves, neckties, rings, bracelets, or other jewelry that may be caught in moving parts. Non-slip footwear is recommended. Wear protective hair covering to contain long hair.

ALWAYS USE SAFETY GLASSES.



Safety glasses should always be worn when working around power tools. In addition, a face, dust mask or respirator should be worn if a cutting operation is dusty. Everyday eyeglasses only have impact resistant lenses and may not prevent eye injury—they are NOT safety glasses.

SECURE WORK.

Clamps or a vise should be used to hold work whenever practical. Keeping your hands free to operate a power tool is safer.

DO NOT OVERREACH.

Keep proper footing and balance at all times by not overreaching.

MAINTAIN TOOLS WITH CARE.

Keep tools clean for the best and safest performance. Always follow maintenance instructions for lubricating, and when changing accessories.

DISCONNECT TOOLS.

Power tools should always be disconnected before servicing or when changing accessories, such as blades, bits, cutters, and the like.

REDUCE THE RISK OF UNINTENTIONAL STARTING.



Make sure the trigger switch; locking button is in the RELEASE position before plugging in a power tool.

USE RECOMMENDED ACCESSORIES.

Consult the owner's manual for recommended accessories. Using improper accessories may increase the risk of personal or by-stander injury.

NEVER STAND ON THE TOOL.

Serious injury could occur if a power tool is tipped, or if a cutting tool is unintentionally contacted.

CHECK FOR DAMAGED PARTS.

Before using a power tool, check for damaged parts. A guard or any other part that is damaged should be carefully checked to determine it would operate properly and perform its intended function. Always check moving parts for proper alignment or binding. Check for broken parts and mountings and all other conditions that may affect the operation of the power tool. A guard, or any damaged part, should be properly repaired or replaced.

DIRECTION OF FEED.

Always feed work into a blade or cutter against the direction of rotation. A blade or cutter should always be installed such that rotation is in the direction of the arrow imprinted on the side of the blade or cutter.

NEVER LEAVE A TOOL RUNNING UNATTENDED – TURN POWER OFF.

Do not leave a tool until it comes to a complete stop. Always turn a power tool OFF when leaving the work area, or, when a cut is finished.

SAFETY

Hazard Symbols:

ELECTRICAL SHOCK!



Never touch electrical wires or components while the motor is running. Exposed, frayed or worn electrical motor wiring can be sources of electrical shock that could cause severe injury or burns.

ACCIDENTAL STARTS!



Before plugging the equipment into an electrical outlet, be sure the trigger switch, locking button is in the "RELEASE" position to prevent accidental starting. Unplug the power tool before performing any service operation.

ROTATING OR MOVING PARTS!



Keep hands, feet, hair, and clothing away from all moving parts to prevent injury. Never operate a power tool with covers, shrouds, or guards removed.

⚠WARNING

Sawing and drilling generates dust. Excessive airborne particles may cause irritation to eyes, skin and respiratory tract. To avoid breathing impairment, always employ dust controls and protection suitable to the material being sawed or drilled; See OSHA (29 CFR Part 1910.1200). Diamond Blades improperly used are dangerous. Comply with American National Standards Institute Safety Code, B7.1 and, Occupational Safety and Health Act covering Speed, Safety Guards, Flanges, Mounting Procedures, General Operating Rules, Handling, Storage and General Machine Conditions.

CALIFORNIA PROPOSITION 65 MESSAGE:

⚠WARNING

Some dust created by power sanding, sawing, grinding, drilling, and other construction activities contain chemicals known [to the State of California] to cause cancer, birth defects or other reproductive harm. Some examples of these chemicals are:

- Lead, from lead-based paints
- Crystalline silica, from bricks and cement and other masonry products and
- Arsenic and chromium, from chemically treated lumber

For further information, consult the following sources:

<http://www.osha-slc.gov/sltc/silicacrystalline/index.html>

http://www.oehha.org/prop65/out_of_date/6022kLstA.html

Your risk from these exposures varies depending on how often you do this type of work. To reduce your exposure to these chemicals, work in a well-ventilated area, and work with approved safety equipment, such as those dust masks that are specially designed to filter out microscopic particles.

SAFETY

ELECTRICAL REQUIREMENTS AND GROUNDING INSTRUCTIONS:

In order to prevent potential electrical shock and injury, the following electrical safety precautions and symbols should be followed at all times!

⚠ WARNING



In case of a malfunction or breakdown, grounding provides a path of least resistance for electric current to reduce the risk of electric shock. This tool is equipped with an electric cord having an equipment-grounding conductor and a grounding plug. The plug must be plugged into a matching outlet that is properly installed and grounded in accordance with all local codes and ordinances.

- Do not modify the plug provided – if it will not fit the outlet; have the proper outlet installed by a qualified electrician
- Improper connections of the equipment-grounding conductor can result in a risk of electric shock. The equipment-grounding conductor is the insulated conductor that has an outer surface that is green, with or without yellow stripes. If repair or replacement of the electric cord or plug is necessary, do not connect the equipment-grounding conductor to a live terminal
- Check with a qualified electrician or service personnel if the grounding instructions are not completely understood, or if in doubt as to whether the tool is properly grounded
- Use only 3-wire extension cords that have 3-prong grounding plugs and 3-pole receptacles that accept the tool's plug
- Repair or replace a damaged or worn cord immediately

⚠ WARNING



This tool is intended for use on a circuit that has an outlet that looks like the one shown in Sketch A of Figure 1. The tool has a grounding plug that looks like the plug illustrated in Sketch A of FIGURE 1. A temporary adapter, which looks like the adapter illustrated in sketches B and C, may be used to

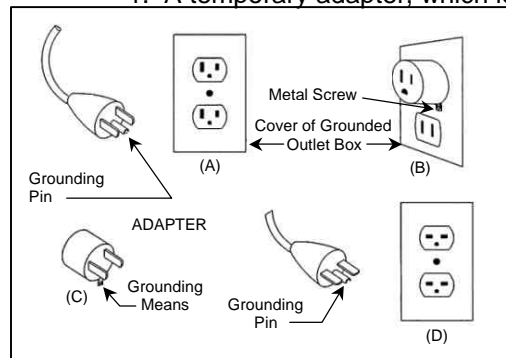

connect this plug to a 2-pole receptacle as shown in Sketch B, if a properly grounded outlet is not available. The temporary adapter should be used only until a properly grounded outlet can be installed by a qualified electrician. The green-colored rigid ear, lug, and the like, extending from the adapter, must be connected to a permanent ground such as a properly grounded outlet box.

NOTE: Use of a temporary adapter is not permitted in Canada.

FIGURE 1

⚠ WARNING



To reduce the risk of electrocution, keep all connections dry and off the ground.

A Ground Fault Circuit Interrupter (GFCI) should be provided on the circuit(s) or outlet(s) to be used for the Brick Saw. Receptacles are available having built-in GFCI protections and may be used for this measure of safety.

When using an extension cord, the GFCI should be installed closest to the power source, followed by the extension cord and lastly, the saw.

SAFETY



To avoid the possibility of the appliance plug or receptacle getting wet, position the saw to one side of a wall mounted receptacle. This will prevent water from dripping onto the receptacle or plug. A "drip loop," shown in FIGURE 2, should be arranged by the user to properly position the power cord relative to the power source.

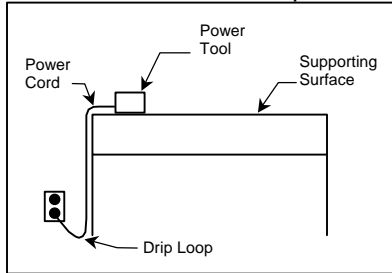

FIGURE 2

The "drip loop" is that part of the cord below the level of the receptacle, or the connector, if an extension cord is used. This method of positioning the cord prevents the travel of water along the power cord and coming in contact with the receptacle.

If the plug or receptacle gets wet, DO NOT unplug the cord. Disconnect the fuse or circuit breaker that supplies power to the tool. Then unplug and examine for presence of water in the receptacle.

⚠ WARNING



Use only extensions cords that are intended for outdoor use. These extension cords are identified by a marking "Acceptable for use with outdoor appliances; store indoors while not in use." Use only extension cords having an electrical rating not less than the rating of the product. Do not use damaged extension cords. Examine extension cords before using and replace if damaged. Do not abuse extension cords and do not yank on any cord to disconnect. Keep cords away from heat and sharp edges. Always disconnect the extension cord from the receptacle before disconnection the product from the extension cord.

⚠ WARNING



Use of undersize extension cords result in low voltage to the motor that can result in motor burnout and premature failure. MK Diamond warns that equipment returned to us showing signs of being run in a low voltage condition, through the use of undersized extension cords will be repaired or replaced totally at the customers expense. There will be no warranty claim.

To choose the proper extension cord,

- Locate the length of extension cord needed in TABLE 1 below.
- Once the proper length is found, move down the column to obtain the correct AWG size required for that length of extension cord.

As an example, a fifty (50) foot extension cord would require an AWG size of 16.

Extension Cord Minimum Gage for Length

Volts	Total Length of Cord in Feet			
	25 ft.	50 ft.	100 ft	150 ft.
120V	AWG 14	AWG 12	AWG Not Recommended	AWG

TABLE 1

SAFETY

SAFETY LABEL LOCATIONS:

Safety labels are located according to Figures 1 through 4 below. The labels contain important safety information. Please read the information contained on each safety label. These labels are considered a permanent part of your saw. If a label comes off or becomes hard to read, contact MK Diamond or your dealer for a replacement

Item	Location	Description	Part No.
1A.	Motor Rear	Caution Use Ground Fault Interrupt	155678
1B.	Motor Rear	Caution Receptacle for Pump Only	154822
1C.	Motor Rear	Service or Warranty Information	155038
2.	Blade Guard	Serial Number	157249-01
3A	Motor Front	Warning Read and Follow Operating Instructions	155806
3B	Motor Front	Motor Specifications	N/A
4A	Pump Left Side	Warning Connect to Grounded Receptacle	N/A
4B	Pump Right Side	Pump Specifications	N/A

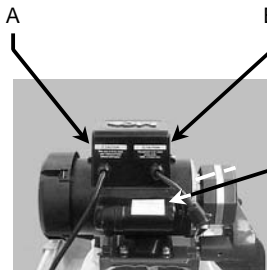
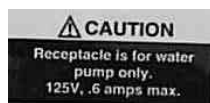

1



C

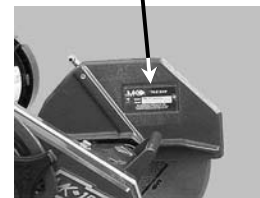

2

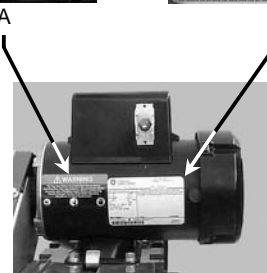
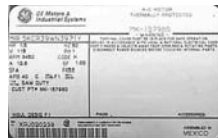

3

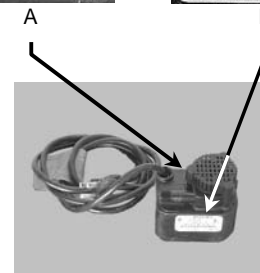

4

TILE SAW SPECIFIC WARNINGS:

⚠WARNING

Wear eye protection.

Use splash hood for every operation for which it can be used.

Disconnect saw before servicing, when changing cutting blades, and cleaning.

Use tool only with smooth edge cutting blades free of openings and grooves.

Replace damaged cutting blade before operating.

SAFETY

PRODUCT SPECIFICATIONS:

The MK-100 is a versatile Tile Saw. Operated and used according to this manual, the MK-100 will provide years of dependable service.

General Description:

The MK-100 Tile Saw is engineered as a tabletop or stand mounted wet tile saw. The saw includes a powerful 115v totally enclosed capacitor start GE motor with a thermal protective overload. The saw is capable of cutting tile up to twenty (20) inches in length, or diagonal cutting tile up to fourteen (14) inches. The saw can cut an object three and one-half (3-1/2) inches thick in one pass.

Motor Specifications:

Motor specifications for the MK-100 are listed in Table 2 below.

Voltage	115 v
Overall Amperage	13.4 a
Motor Only Amperage	12.8 a
Frequency	60 Hz
RPM	3450 rpm
Horse Power	1.5 hp
Weight	97 lbs

Table 2

Thermal Overload Protection:

The motor is protected by a thermal overload equipped with a manual reset.

Blade Capacity:

The MK-100 uses a ten (10) inch (254mm) diameter, wet cutting continuous rim, MK Diamond blade with a one-sixteenth 1/16 inch (15.875 mm) cutting width and a five-eighths (5/8) inch (15.875 mm) arbor.

Tile Types:

The MK-100 can cut a variety of tile types including Porcelain, Terracotta, Marble, Quarry and Slate, or almost any other non-ferrous material.

NOTE:

The MK-100 is not designed to cut plastic or ferrous (metals) material.

UNPACKING, TRANSPORT, UNIVERSAL STAND and ASSEMBLY

UNPACKING:

Your MK-100 has been shipped from the factory thoroughly inspected. Only minimal assembly is required.

CAUTION Use proper lifting techniques when lifting the MK-100.

If not done, remove the MK-100, Cutting Head and accessory box from the carton.

CONTENTS:

In your container, you will find one (1) MK-100 frame and water basin, one (1) MK-100 Cutting Head, one (1) 10-inch wet cutting continuous rim diamond blade, one (1) adjustable cutting guide, one (1) electric water pump, one (1) pump discharge fitting, one (1) cooling transfer tube, one (1) flow adjusting clamp, one (1) drain plug, one (1) blade wrench one (1) splash guard, one (1) owners manual, one (1) pump manual and one (1) warranty card.



MK-100 Frame and Water Basin



MK-100 Cutting Head



Diamond Blade

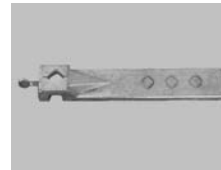

Adjustable Cutting Guide



Electric Water Pump



Pump Discharge Fitting



Cooling Transfer Tube



Flow Adjusting Clamp



Drain Plug



Wrench



Splash Guard



Owners Manual



Pump Manual

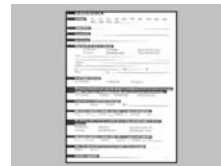

Warranty Card

TRANSPORT:

- CAUTION**
1. The MK-100 weighs approximately ninety-seven (97) pounds; use care when transporting.
 2. Never transport the MK-100 with water in the Water Basin.

The MK-100 is designed with a rigid frame and removable Cutting Head. Two people are required to transport the MK-100 with the Cutting Head installed. The Cutting Head must be removed first, if one person is transporting the saw (see Cutting Head Installation and Removal in the following section).

To lift the saw using two people, each person will grasp the front and back portion of the frame. To lift the saw using one person, remove the Cutting Head first, and then grasp the front and back of the frame. Transport the Cutting Head and the Frame separately.

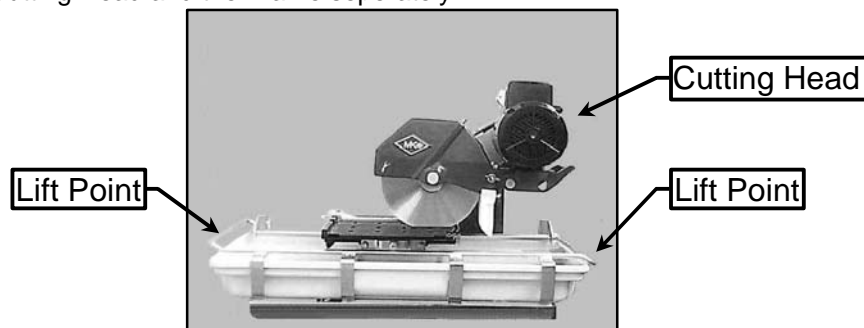

UNPACKING, TRANSPORT, UNIVERSAL STAND and ASSEMBLY

UNIVERSAL STAND:

⚠CAUTION The MK-100 weighs eighty-five (85) pounds; follow the guidelines for transport in the TRANSPORT section, when placing it on the stand.

Note: If using the MK Diamond, Universal Stand, follow the following steps.

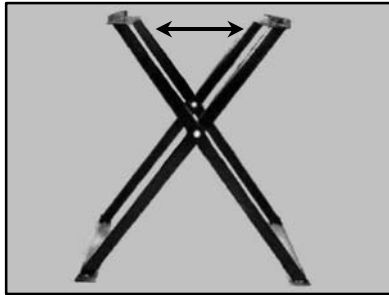

(A)
Open the Universal Stand
and place on flat surface

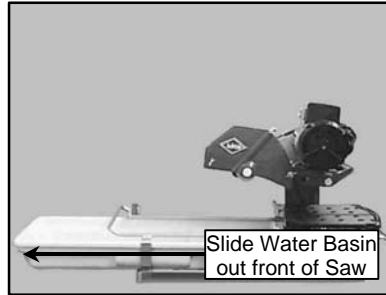

(B)
Remove Water Basin

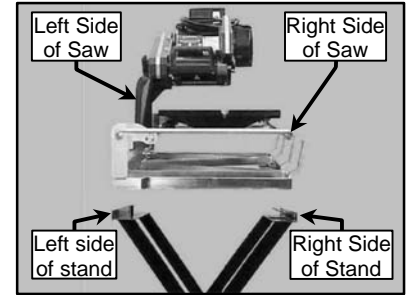

(C)
Orient the Saw
to the Stand

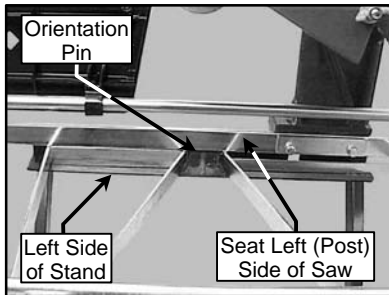

(D)
Seat Left (Post) Side of saw
onto stand between stand
Orientation Pin

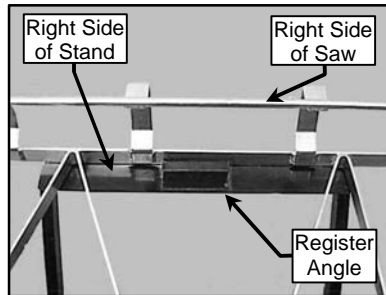

(E)
Seat Right Side of saw onto
stand between stand and
Register Angle

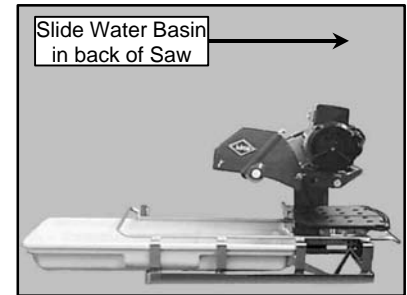

(F)
Reinstall the Water Basin

UNPACKING, TRANSPORT, UNIVERSAL STAND and ASSEMBLY

ASSEMBLY:

Follow the assembly instructions to prepare your MK-100 for operation.

1. Cutting Head Installation:

NOTE: If the Cutting Head is installed, go to step 2.

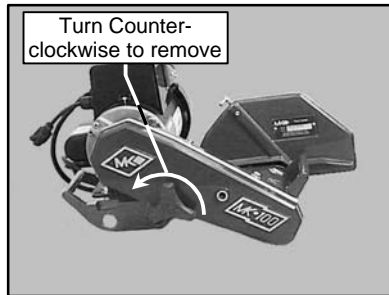

(A)
Remove Adjusting Knob

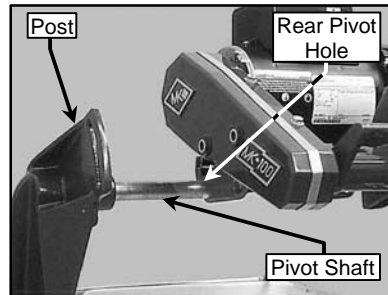

(B)
Align Cutting Head rear Pivot Hole to the Post, Pivot Shaft

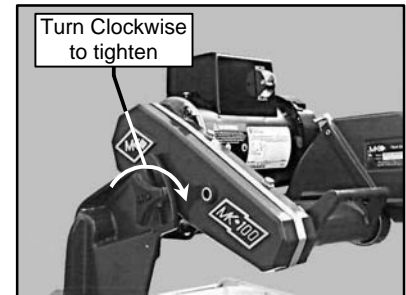

(C)
Install the Cutting Head onto the Post, Pivot Shaft and Install The Adjusting Knob

2. Diamond Blade Installation:

NOTE: When installing the Retaining Screw, do not "cross-thread" and DO NOT over tighten the screw.

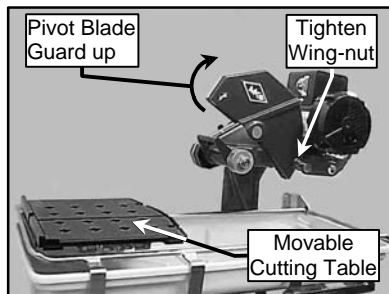

(A)
Position Movable Cutting Table to the front of the saw and raise the Blade Guard

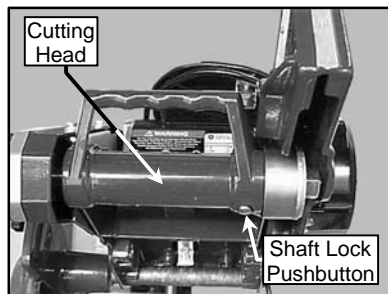

(B)
Locate the Shaft Lock pushbutton on the underside of the Cutting Head

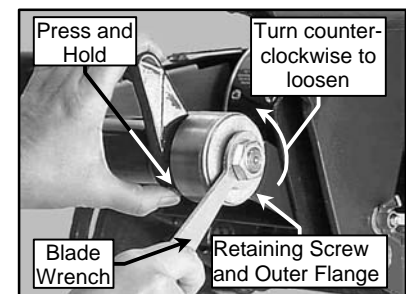

(C)
Depress and hold the Shaft Lock pushbutton and remove Retaining Screw and Outer Flange using the Blade Wrench

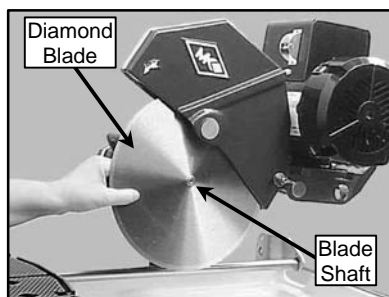

(D)
Install Diamond Blade onto Blade Shaft

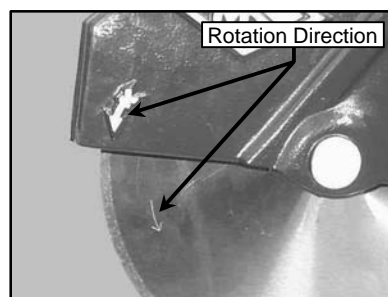

(E)
Verify the Blade is seated on the Blade Shaft and direction of rotation is correct

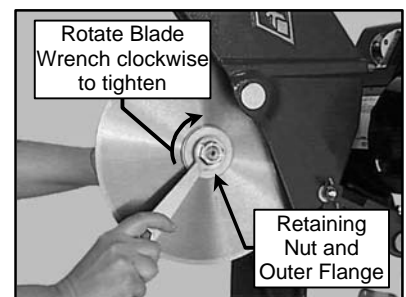

(F)
Install Retaining Nut and Outer Flange, depress and hold the Shaft Lock pushbutton and Tighten

UNPACKING, TRANSPORT, UNIVERSAL STAND and ASSEMBLY

3. Adjustable Cutting Guide Installation:

NOTE: The Adjustable Cutting Guide can be used on either side of the Diamond Blade.

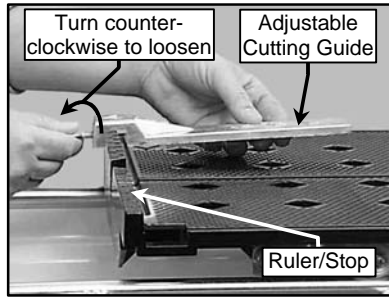

(A)
Loosen Adjustable Cutting Guide retaining thumbscrew and place it over the Movable Cutting Table Ruler/Stop

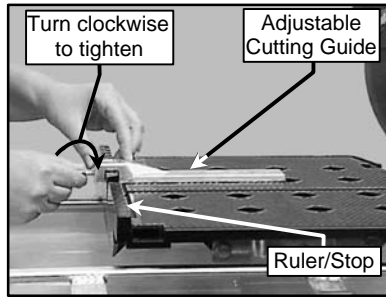

(B)
Place the Adjustable Cutting Guide onto the Movable Cutting Table Ruler/Stop and tighten the retaining thumbscrew

4. Splash Guard Installation:

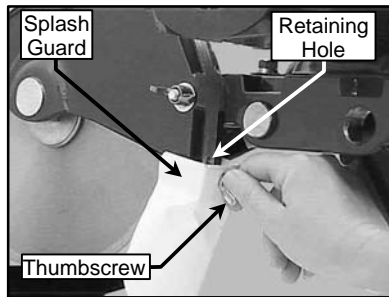

(A)
Install the retaining thumbscrew through the washer and Splash Guard then align to the hole found on back of the Blade Guard

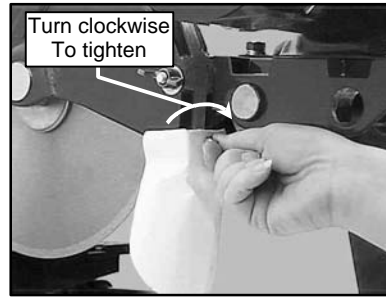

(B)
Install the Splash Guard onto the Blade Guard

5. Water Pump Preparation:

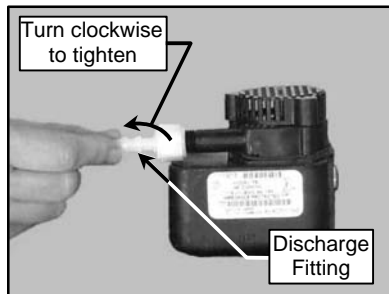

(A)
Install Water Pump Discharge Fitting

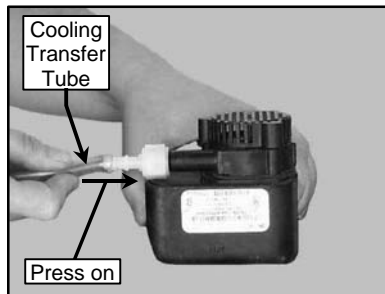

(B)
Press one end of the Cooling Transfer Tube onto the Water Pump Discharge Fitting

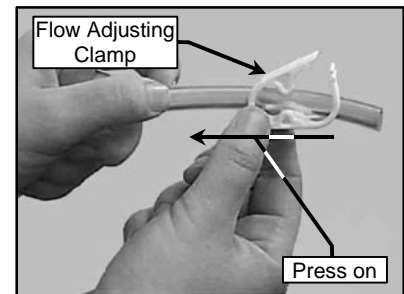

(C)
Slide Cooling Flow Adjusting Clamp onto the Cooling Transfer Tube

SETUP, ADJUSTMENT and OPERATION

SETUP:

1. Pre-start Inspection:

Prior to beginning work, a pre-start inspection of the saw should be performed.

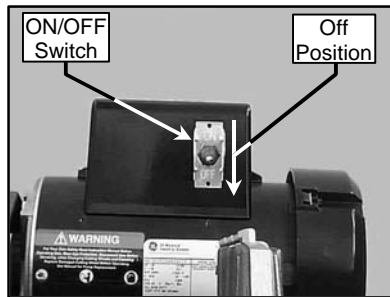

(A)
Ensure the ON/OFF Switch is in the OFF position

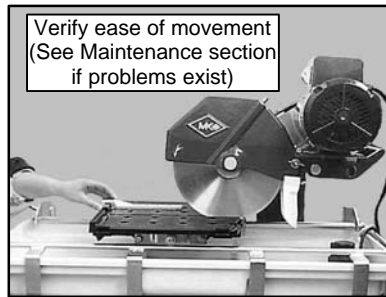

(B)
Verify the Movable Cutting Table moves freely

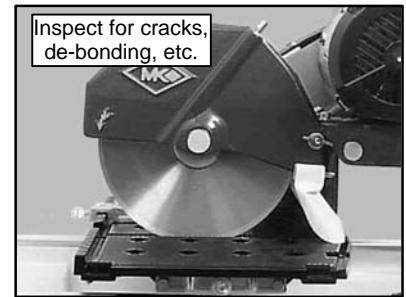

(C)
Inspect the Diamond Blade for damage – verify the blade is correct for the material being cut

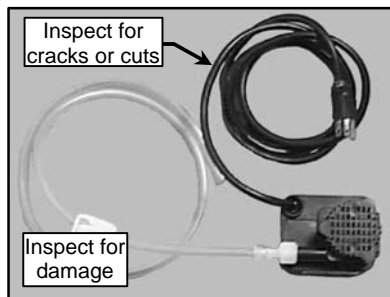

(D)
Inspect the Pump Assembly for damage – ensure the cord is free of cracks or cuts



(E)
Inspect the MK-100 for damage – ensure the cord is free of cracks or cuts

2. Connecting the Water Pump:

⚠WARNING 1. To prevent the possibility electrical shock, the MK-100 MUST be de-energized when connecting the Water Pump.



2. To prevent the possibility of electrical shock, use only MK Diamond qualified replacement parts

NOTE: To prevent pump damage, the Water Pump must be disconnected if cutting with a Dry Blade.

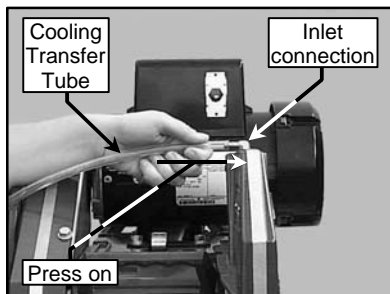

(A)
Connect the Cooling Transfer Tube to the inlet connection of the Blade Guard

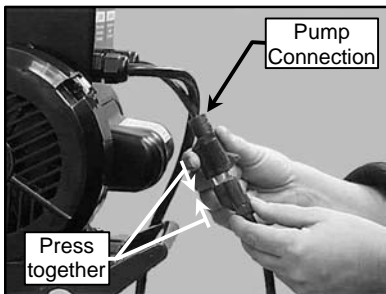

(B)
Connect the Water Pump power cord to the connection found on the back of the motor

SETUP, ADJUSTMENT and OPERATION

3. Water Pump Setup for Operation:

The Water Pump can be setup for operation in two ways, External Water Source or Re-circulation.

NOTE: If using a dry blade for operation, DO NOT connect the water pump.

I. External Water Source:

This is the preferred method of cooling.

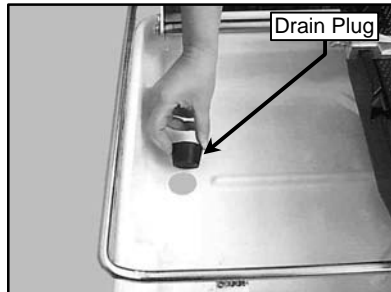

(A)
Remove the Drain plug

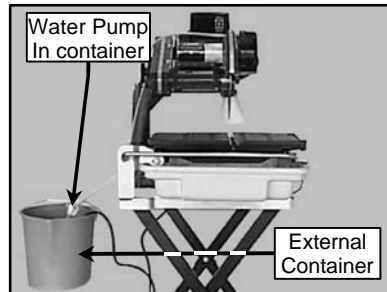

(B)
Place the Water Pump
In an external container

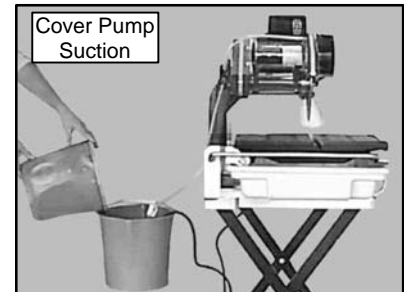

(C)
Fill the external container until
water completely covers the
Water Pump suction

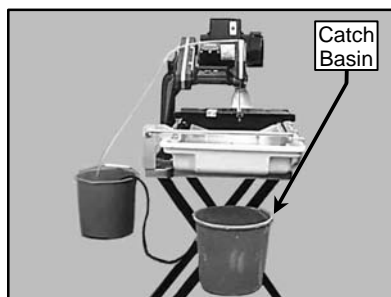

(D)
Place an external catch
basin below the Water
Basin drain hole

II. Re-circulation:

NOTE: When using the re-circulation method, the water should be changed often for longer pump life.

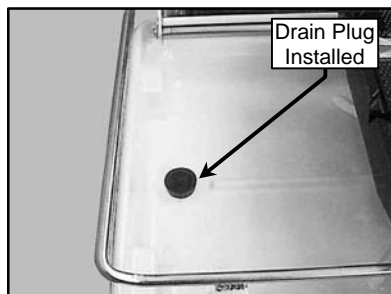

(A)
Ensure the Drain Plug is
Installed in the Water Basin

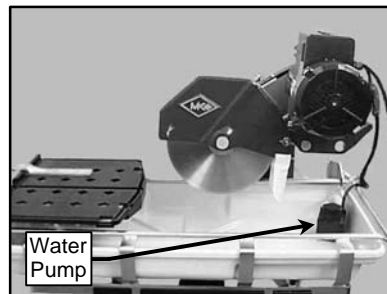

(B)
Place the Water Pump in the
back of the Water Basin

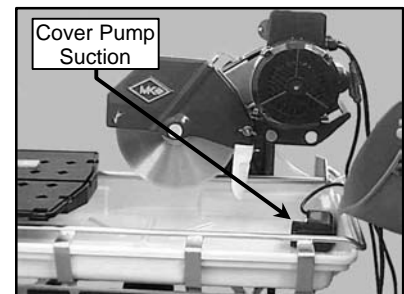

(C)
Fill the Water Basin until water
completely covers the
Water Pump suction

SETUP, ADJUSTMENT and OPERATION

4 MK-100 Setup for Operation:

- ⚠CAUTION** 1. Before powering or starting, check for damage that could prevent this equipment from proper operation or performing its intended function. Check for binding and alignment of moving parts. Check for damaged, broken, or missing parts.
2. Verify the On/Off switch is in the OFF position.
3. Before connecting the MK-100 to a power supply, be sure the voltage, cycle and phase of the job site power source meet the requirements of TABLE 3

VOLTAGE:	115v
CYCLE:	60hz
PHASE:	1-phase

TABLE 3

4. If using an extension power cord, make sure the length and wire gauge correspond to the requirements listed in TABLE 1 on page 9. An extension power cord that is too small in wire gauge (diameter), or too long in length, will cause the motor to overheat and could cause premature failure.
5. Use an approved Ground Fault Circuit Interrupter (GFCI)
6. Do not cover the motor vents as this could lead to motor overheating.

NOTE: In order to avoid breaker tripping, a 20-amp circuit breaker should be used.

Portable Generator:

If using a portable generator to provide power, ensure the generator meets the following minimum requirements:

8 KW

120/240 volts

66.7/33.3 amps

Single Phase

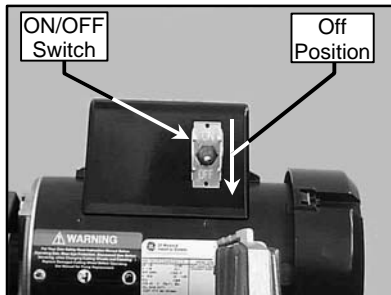

(A)
Ensure the ON/OFF Switch is in the OFF position

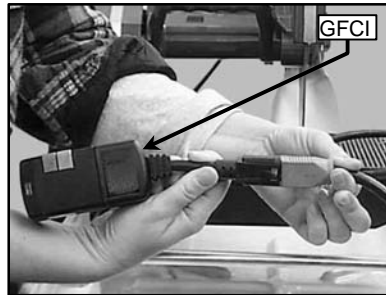

(B)
Plug MK-100 into the GFCI

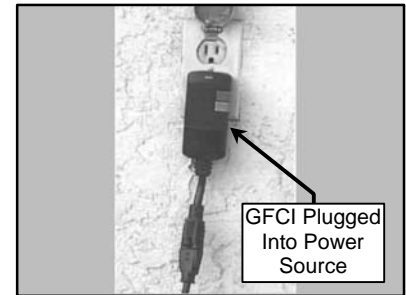

(C)
Plug the GFCI into the Power source

5. Set Cutting Depth:

⚠CAUTION When loosening the Cutting Head Adjusting Knob, the Cutting Head will pivot down unless held.

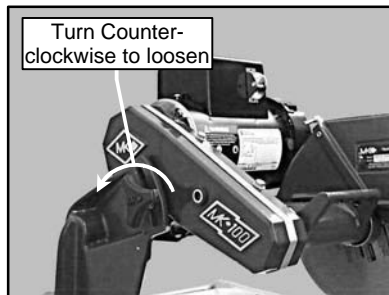

(A)
Loosen Cutting Head Adjusting Knob

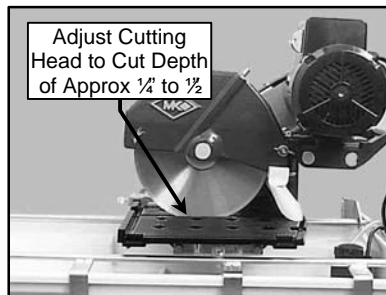

(B)
Set cutting depth approximately 1/4 to 1/2 inch below the Movable Cutting Table

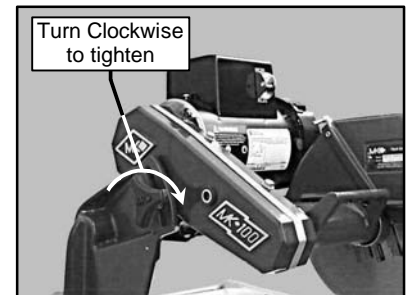

(C)
Ensure the Adjusting Knob is tight

SETUP, ADJUSTMENT and OPERATION

ADJUSTMENT and OPERATION:

1. Cutting Straight Edges:

⚠CAUTION DO NOT FORCE THE TOOL. It will do the job better and safer at the rate for which it was designed.

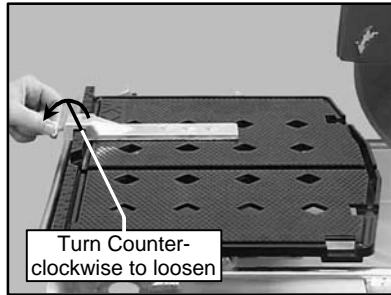

(A)
Loosen the Adjustable Cutting Guide retaining thumbscrew

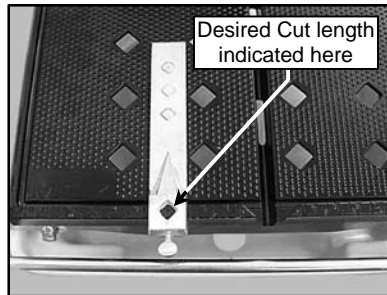

(B)
Position the Adjustable Cutting Guide to desired cut length indicated inside the diamond

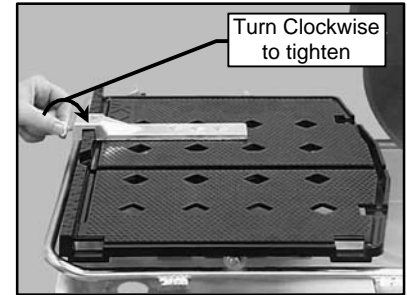

(C)
Tighten the retaining thumbscrew

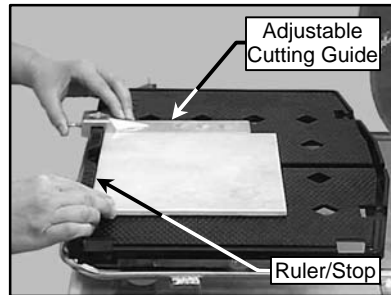

(D)
Place the tile against the Ruler/Stop and Cutting Guide

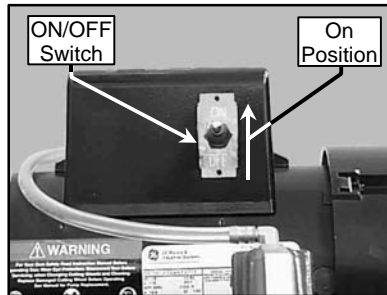

(E)
Turn the motor ON

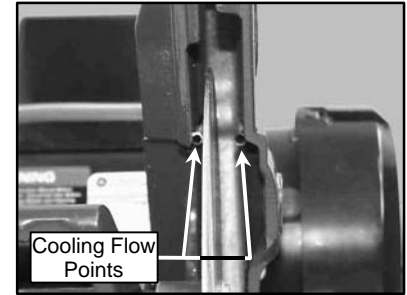

(F)
Verify proper cooling flow on both sides of the blade (See Maintenance Section to increase/decrease flow)

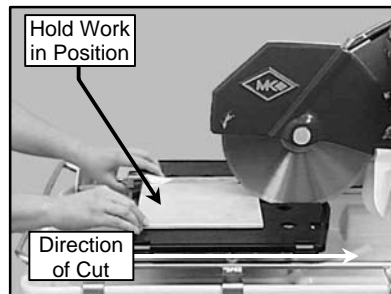

(G)
Perform the cut

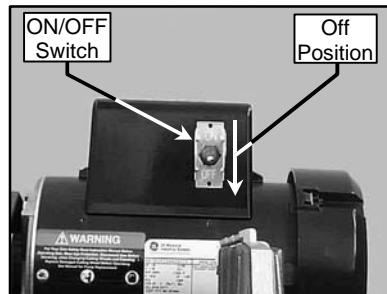

(H)
Turn the motor OFF when work is complete

SETUP, ADJUSTMENT and OPERATION

2. Diagonal Cutting:

NOTE: To cut diagonal, the Dual 45° Flat Angle Guide (MK Diamond Part No. 134557-MK) should be used.

⚠CAUTION DO NOT FORCE THE TOOL. It will do the job better and safer at the rate for which it was designed.

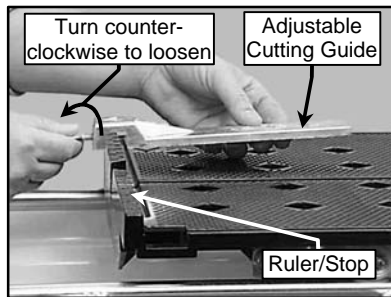

(A)
Remove the Adjustable Cutting Guide

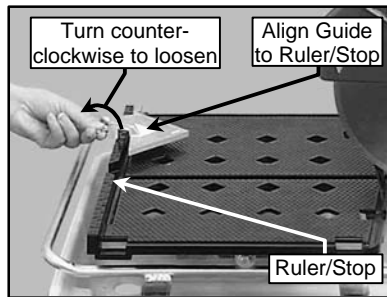

(B)
Place the Dual 45° Flat Angle Guide on the Ruler/Stop

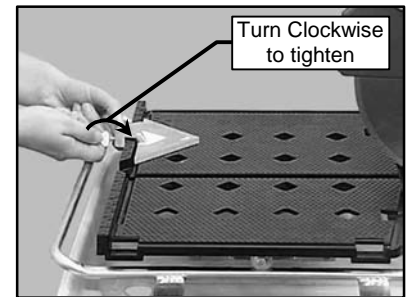

(C)
Position the Dual 45° Flat Angle Guide and tighten the retaining thumbscrew

NOTE: If Cutting the tile in two equal halves, align the tile in the V-notch of the Movable Cutting Table Ruler/Stop.

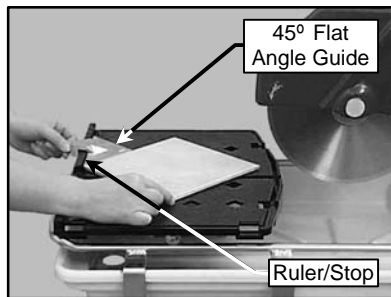

(D)
Position the tile against the Dual 45° Flat Angle Guide and the Ruler/Stop

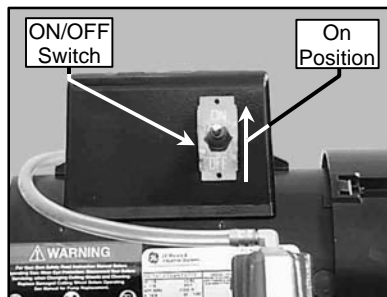

(E)
Turn the motor ON

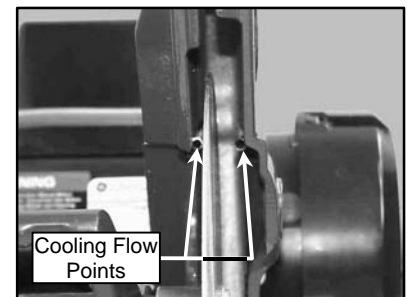

(F)
Verify proper cooling flow on both sides of the blade (See Maintenance Section to increase/decrease flow)

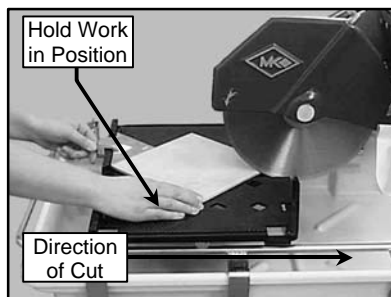

(G)
Perform the cut

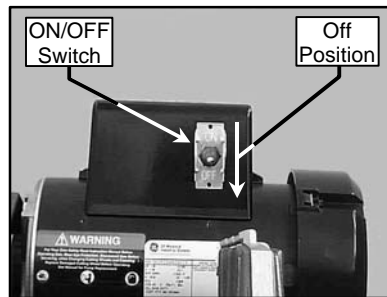

(H)
Turn the motor OFF when work is complete

SETUP, ADJUSTMENT and OPERATION

3. 45° Miter Cutting:

NOTE: To cut 45° Miters, the 45° Bullnose Miter Guide (MK Diamond Part No. 134585-MK) should be used.

⚠CAUTIONDO NOT FORCE THE TOOL. It will do the job better and safer at the rate for which it was designed.

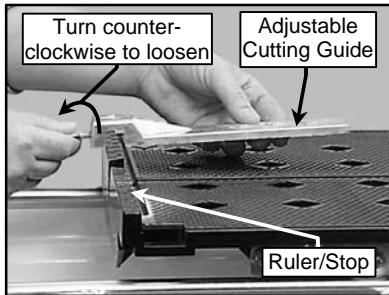

(A)
Remove the Adjustable Cutting Guide

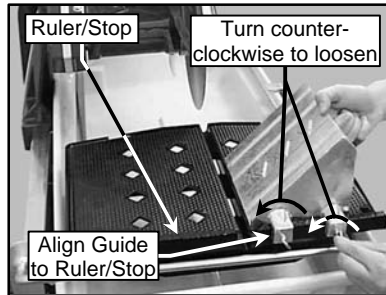

(B)
Place the 45° Bullnose Miter Guide on the Ruler/Stop

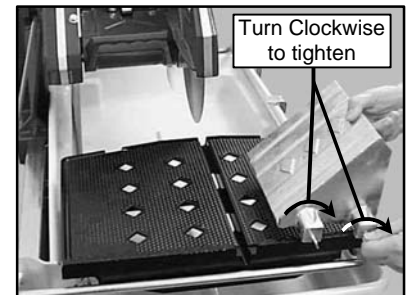

(C)
Position the 45° Bullnose Miter Guide and tighten the retaining thumbscrew

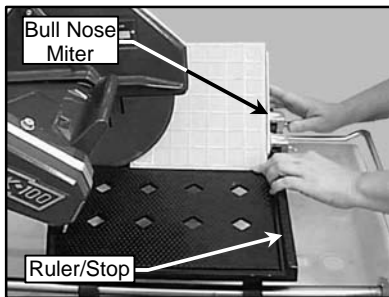

(D)
Position the tile on the 45° Bullnose Miter Guide and the Ruler/Stop

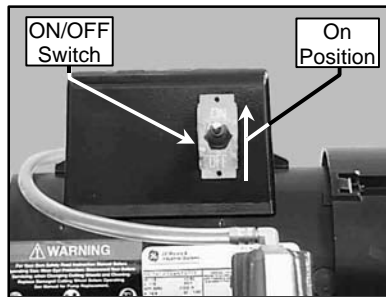

(E)
Turn the motor ON

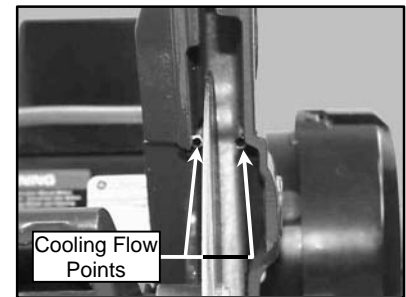

(F)
Verify proper cooling flow on both sides of the blade (See Maintenance Section to increase/decrease flow)

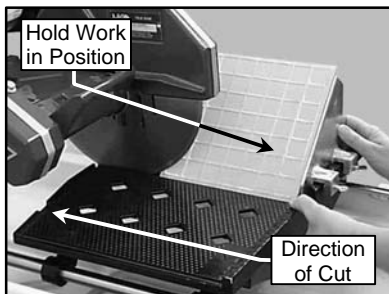

(G)
Perform the cut

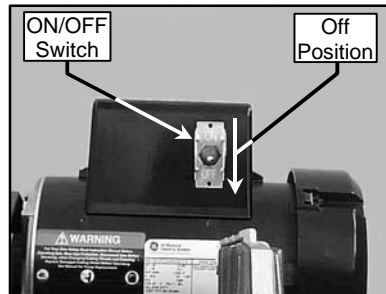

(H)
Turn the motor OFF when work is complete

SETUP, ADJUSTMENT and OPERATION

4. Off-angle Cutting:

NOTE: To cut angles other than 45° angles or Miters, a 90° Protractor (MK Diamond Part No. 134569-MK) should be used.

⚠CAUTION DO NOT FORCE THE TOOL. It will do the job better and safer at the rate for which it was designed.

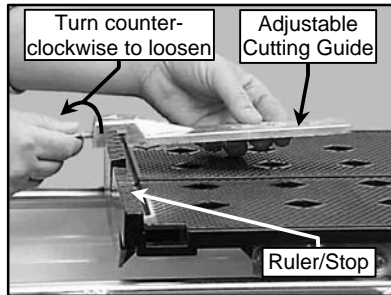

(A)
Remove the Adjustable Cutting Guide

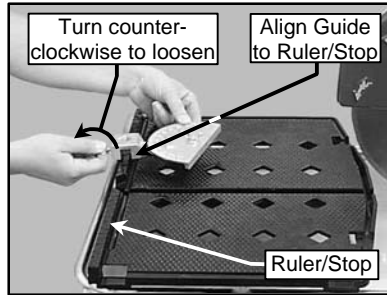

(B)
Place the 90° Protractor on the Ruler/Stop

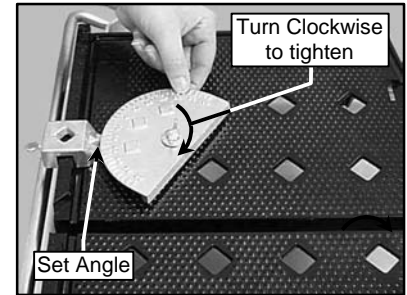

(C)
Set the desired angle and tighten the thumbscrew

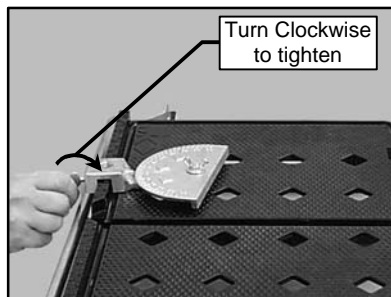

(D)
Position the 90° Protractor and tighten the retaining thumbscrew

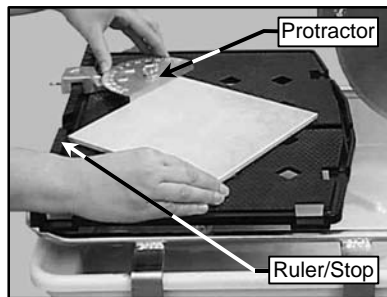

(D)
Position the tile against the 90° Protractor and the Ruler/Stop

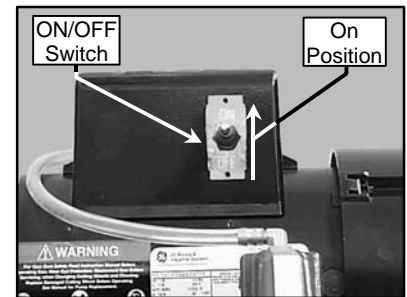

(E)
Turn the motor ON

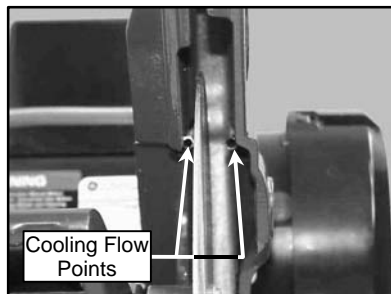

(F)
Verify proper cooling flow on both sides of the blade (See Maintenance Section to increase/decrease flow)

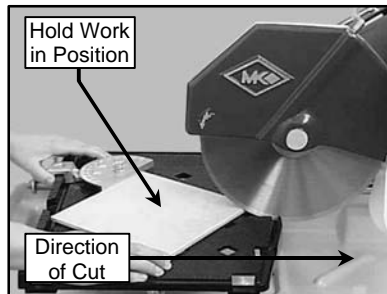

(G)
Perform the cut

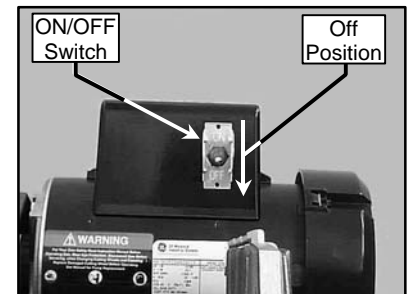

(H)
Turn the motor OFF when work is complete

SETUP, ADJUSTMENT and OPERATION

5. Adjusting the Cutting Head:

⚠CAUTION The Cutting Head is heavy! Care must be used when changing the position of the Cutting Head.

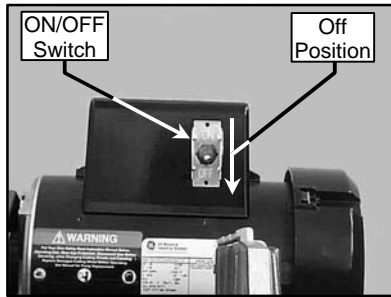

(A)
Ensure the ON/OFF Switch is in the OFF position

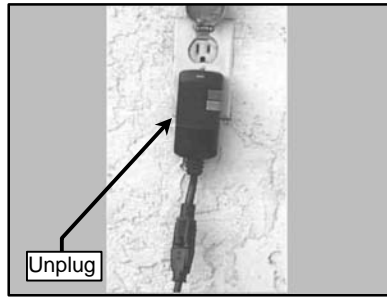

(B)
Unplug the GFCI from the power source

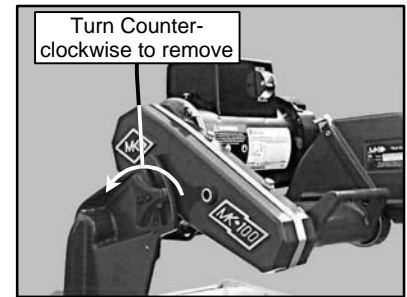

(C)
Remove Adjusting Knob

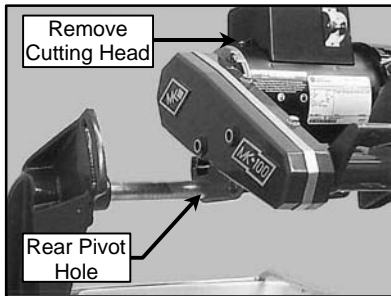

(D)
Remove the Cutting Head from The rear pivot hole

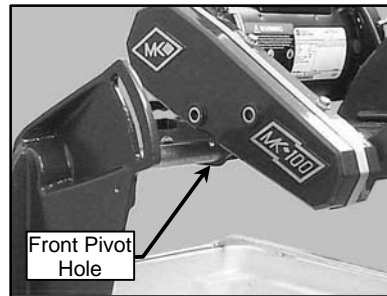

(E)
Install the Cutting Head onto the front pivot hole

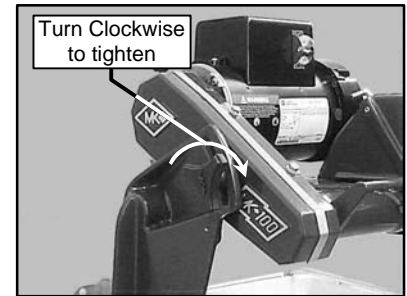

(F)
Install the Adjusting Knob

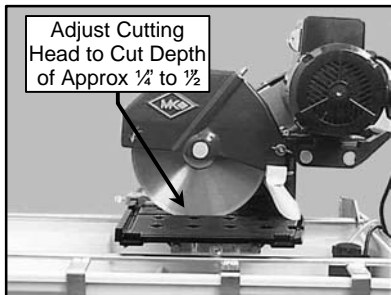

(G)
Set cutting depth approximately 1/4 to 1/2 inch below the Movable Cutting Table

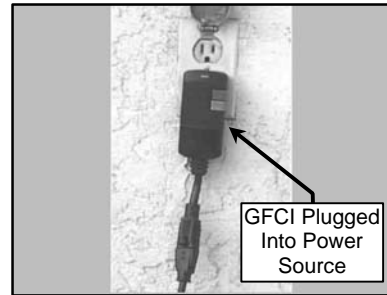

(H)
Plug the GFCI into the power source

SETUP, ADJUSTMENT and OPERATION

6. Adjusting the Post for Maximum Cutting Length:

⚠CAUTION The Cutting Head and Post are heavy! Care must be used when changing the position of the Cutting Head.

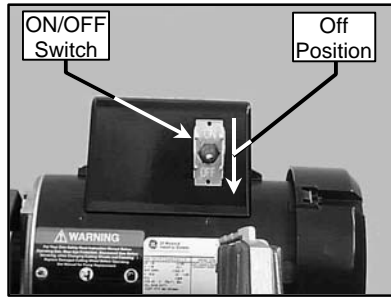

(A)
Ensure the ON/OFF Switch is in the OFF position

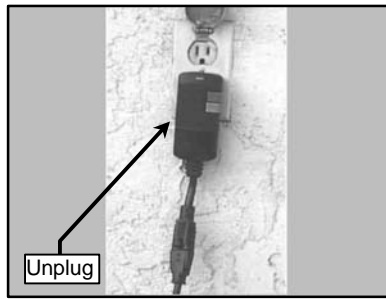

(B)
Unplug the GFCI from the power source

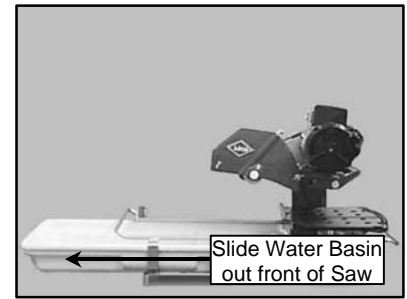

(C)
Remove Water Basin

⚠CAUTION Hold the Post when removing the Post Support Plate.

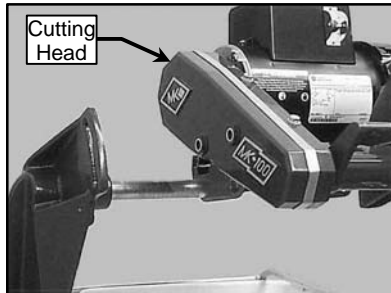

(D)
Remove the Cutting Head (See Adjusting the Cutting Head)

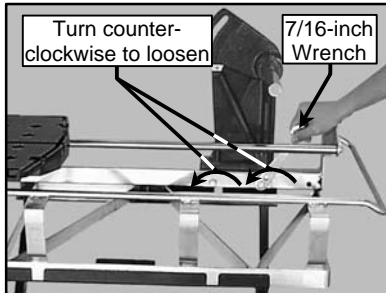

(E)
Loosen the Post Support Plate and retaining bolts

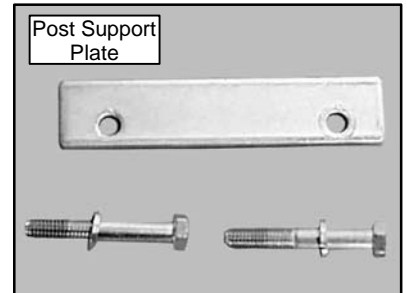

(F)
Remove the Post Support Plate and retaining bolts

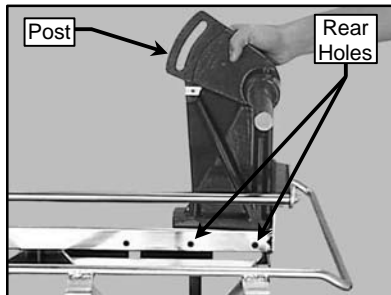

(G)
Relocate the Post to the rear Post retaining holes

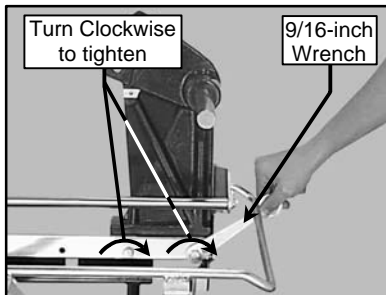

(H)
Install and tighten the Post Support Plate and retaining bolts

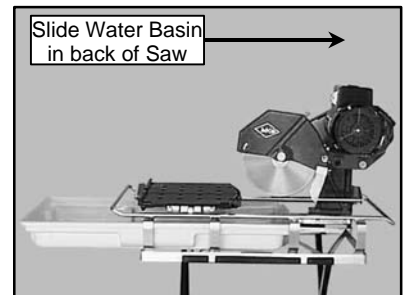

(I)
Install the Water Basin

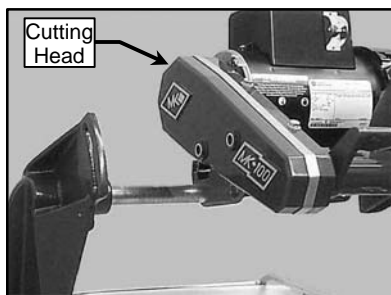

(J)
Install the Cutting Head (See Adjusting the Cutting Head)

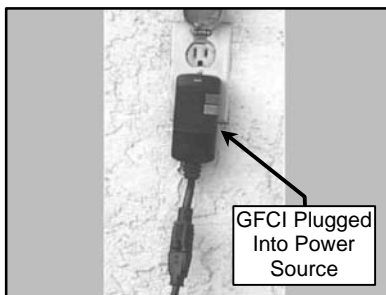

(K)
Plug the GFCI into the power source

SETUP, ADJUSTMENT and OPERATION

7. Cleanup:

NOTE: If an external water source was used, steps A through C may be skipped

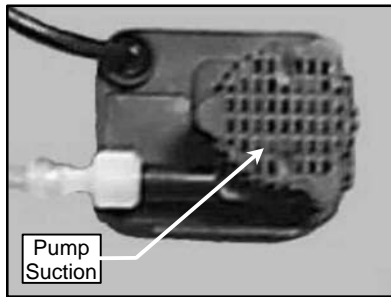

(A)
Clean the Water Pump suction of all debris

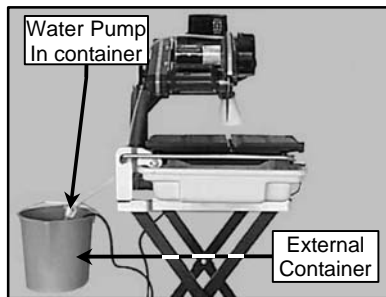

(B)
Place the Water Pump in an external container

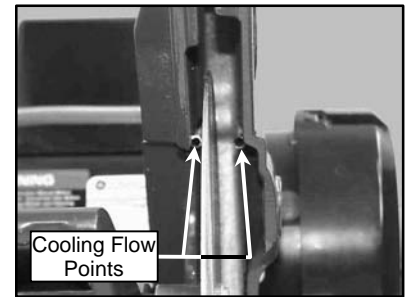

(C)
Run the MK-100 until clear water is seen at the blade cooling ports (Approx. 1 minute)

⚠CAUTION Ensure the saw is disconnected before completing the remainder of the cleanup process.

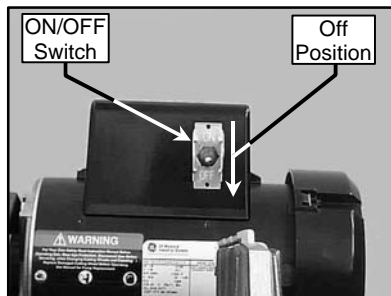

(D)
Ensure the ON/OFF Switch is in the OFF position

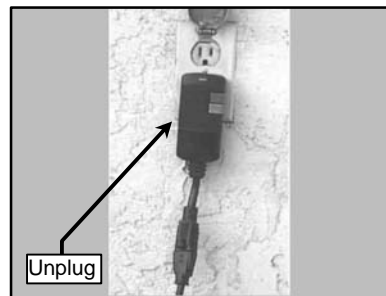

(E)
Unplug the GFCI from the Power source

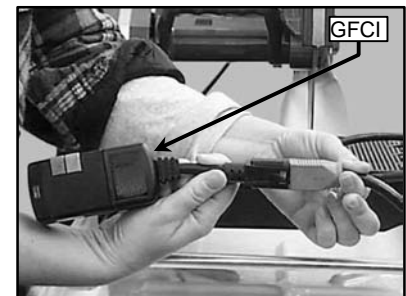

(F)
Unplug MK-100 from the GFCI

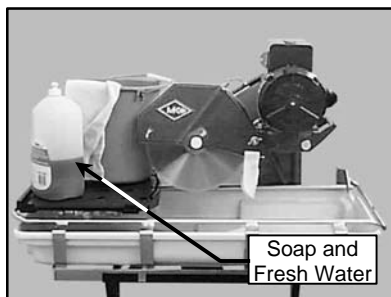

(G)
Clean the MK-100 with soap and clean water

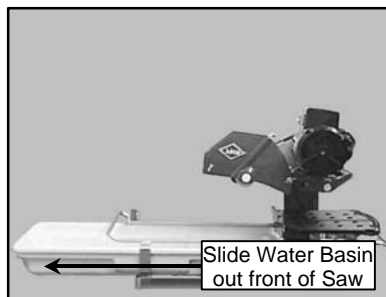

(H)
Remove the Water Basin from the MK-100

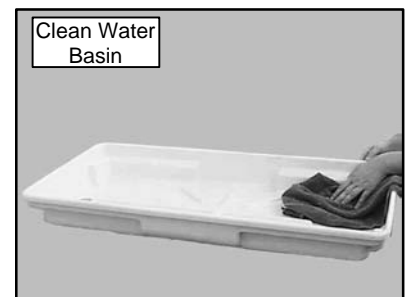

(I)
Clean the Water Basin

SETUP, ADJUSTMENT and OPERATION

⚠CAUTION Ensure water is not forced into the motor casing when cleaning.

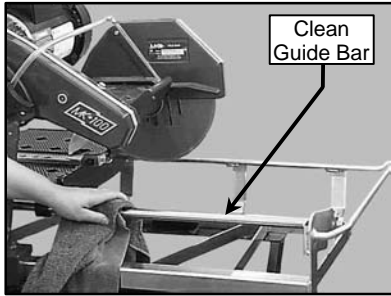

(J)
Clean the Movable Cutting
Table Guide Bar

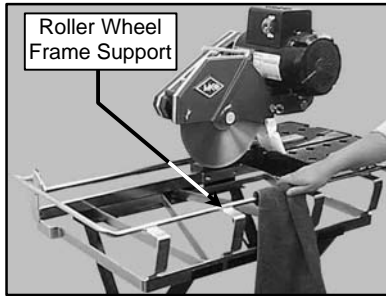

(K)
Clean the Movable Cutting
Table Roller Wheel Frame
Support

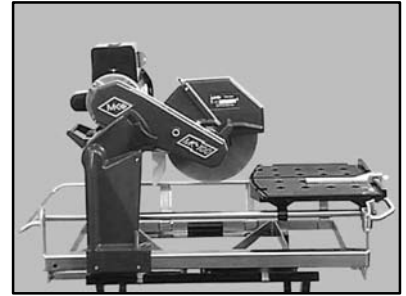

(L)
Clean the remainder of the
MK-100

MAINTENANCE AND TROUBLESHOOTING

MAINTENANCE:

1. New Maintenance:

Perform the following after initial purchase and operation of the MK-100.

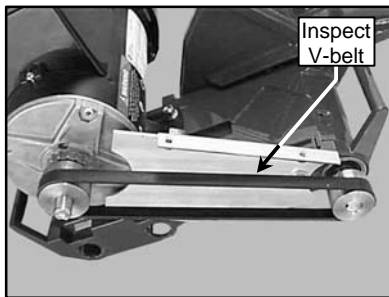

(A)

Check and adjust V-belt tension Following 1st 48 hours of operation (See V-belt Inspection)

2. Maintenance Following Use:

To extend the life of the MK-100, the following procedure should be performed after each use. Lubricate all points listed below with light oils such as, 3 in 1, WD-40, etc.

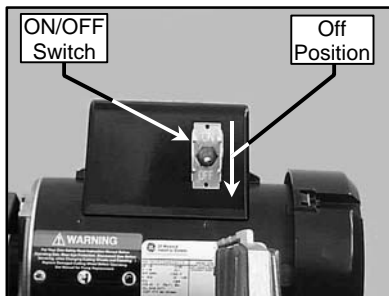

(A)

Ensure the ON/OFF Switch is in the OFF position

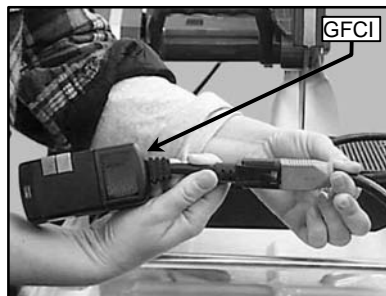

(B)

Unplug MK-100

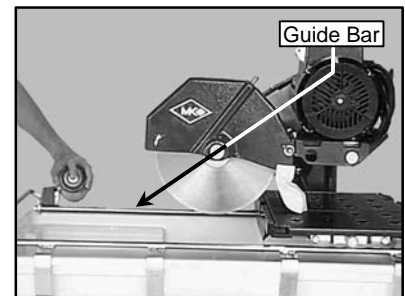

(C)

Lubricate the Guide Bar

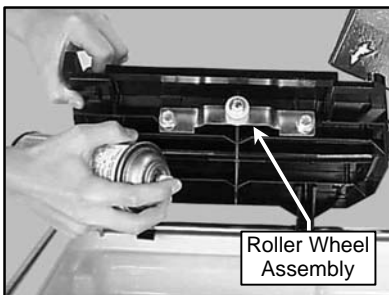

(A)

Lubricate the Roller Wheel Assembly

MAINTENANCE AND TROUBLESHOOTING

3. Monthly Maintenance:

The following maintenance should be performed Monthly.

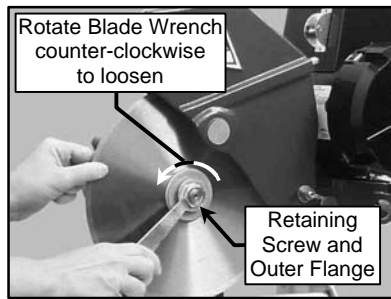

(A)
Remove the Diamond Blade

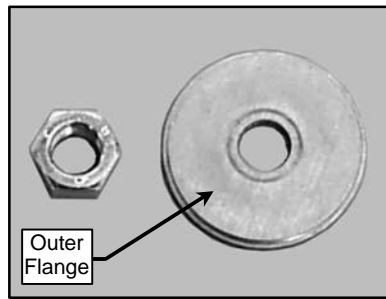

(B)
Lubricate the Outer Flange and Retaining-nut

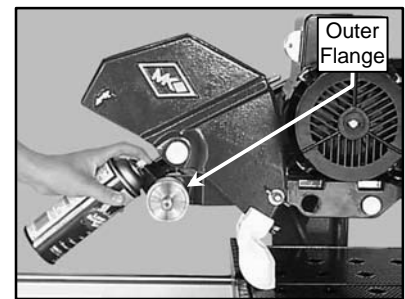

(C)
Lubricate the Inner Flange

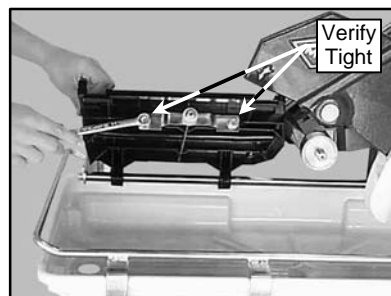

(D)
Verify the Roller Wheel Assembly is tight and in good condition

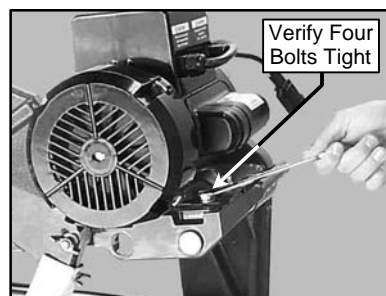

(E)
Verify all motor mounting Bolts are tight

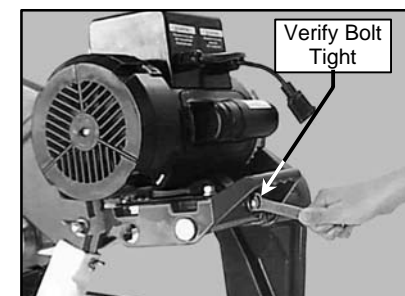

(F)
Verify the Motor Adjustment Strap is tight

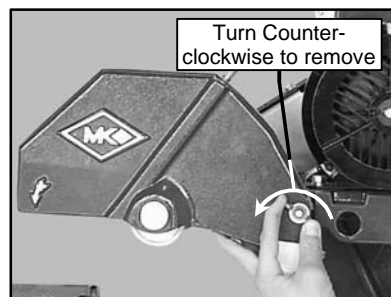

(G)
Remove the Blade Guard

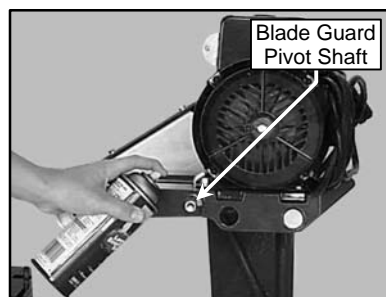

(H)
Lubricate the Blade Guard Pivot Shaft

MAINTENANCE AND TROUBLESHOOTING

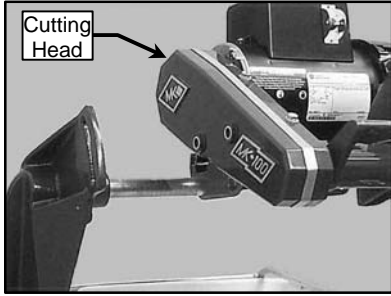

(I)
Remove the Cutting Head (See
Adjusting the Cutting Head)

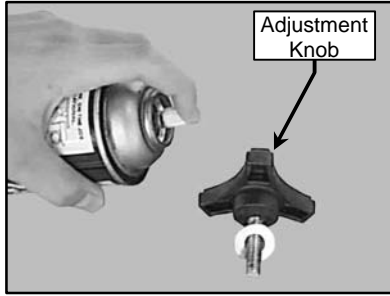

(J)
Lubricate the Cutting Head
Adjustment Knob

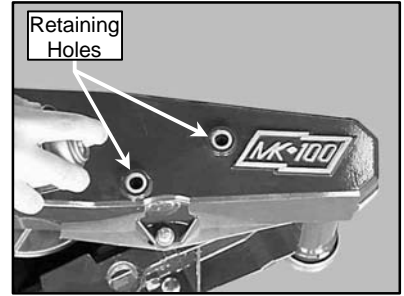

(K)
Lubricate the Cutting Head
Adjustment Knob retaining holes

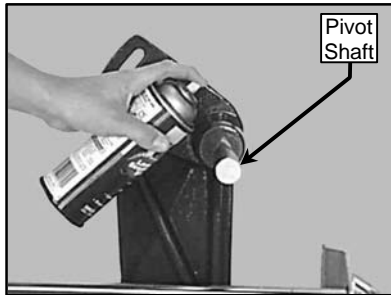

(L)
Lubricate the Cutting Head
Pivot Shaft

4. Flow Adjustment:

NOTE: If flow to the diamond blade requires adjustment, perform the following actions.

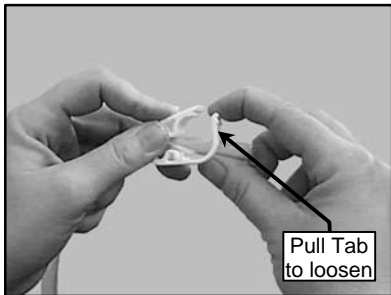

(D)
Increase cooling flow by
releasing the Flow Adjusting
Clamp

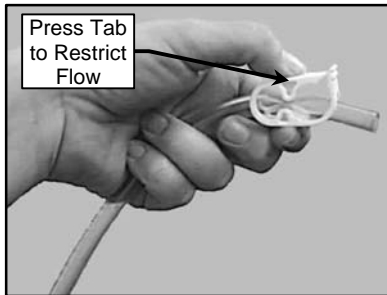

(E)
Reduce cooling flow by
Pressing down on the Flow
Adjusting Clamp

MAINTENANCE AND TROUBLESHOOTING

TROUBLESHOOTING:

1. Blade Dressing:

Like most cutting instruments, a diamond blade performs best when it is dressed. Over time and use, diamonds on the outer edge of the blade will become smoothed or “glazed” over. This will reduce grinding efficiency and may cause the blade to “wander” or bend giving the illusion of an alignment problem. When this occurs, the blade will need to be dressed. The diamond blade can be dressed using the MK Dressing Stick (part number 152972) and by following the steps below.

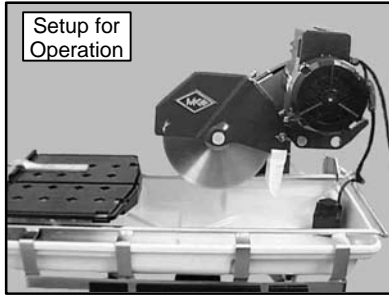

(A)
Setup the MK100 for operation
(See Setup, Adjustment
and Operation)

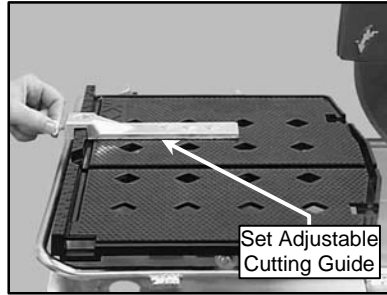

(B)
Set the Adjustable Cutting Guide
to cut a 1/16-strip

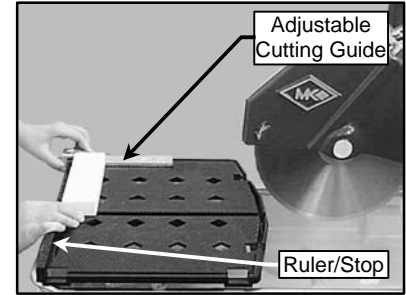

(C)
Position the Dressing Stick

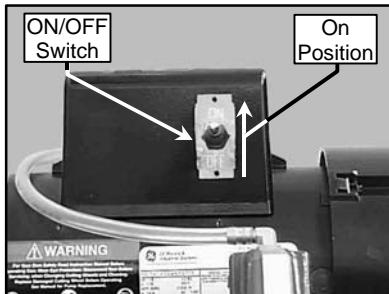

(D)
Turn the motor ON

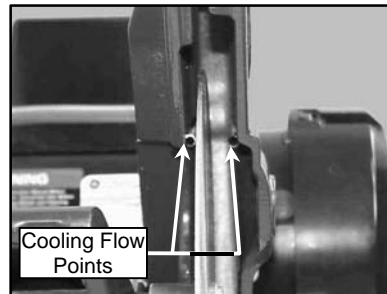

(E)
Verify proper cooling flow on
both sides of the blade (See
Maintenance Section to
increase/decrease flow)

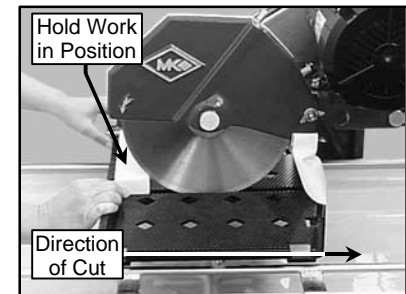

(F)
Cut the Dressing Stick 7 or 8
times to dress the Blade

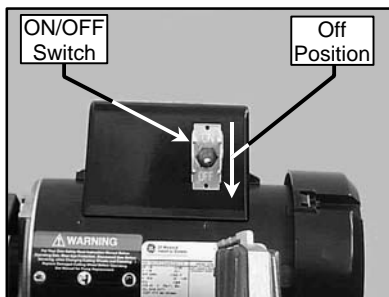

(G)
Ensure the ON/OFF Switch
is in the OFF position

MAINTENANCE AND TROUBLESHOOTING

2. Diamond Blade Change-out:

NOTE: When installing the Retaining Screw, do not "cross-thread" and DO NOT over tighten the screw.

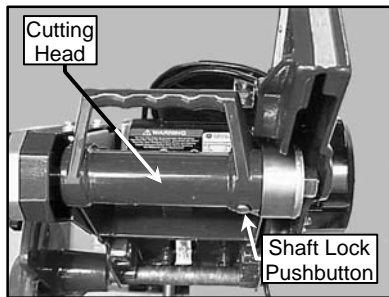

(A)
Locate the Shaft Lock pushbutton on the underside of the Cutting Head

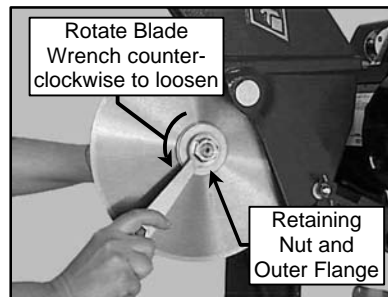

(B)
Remove Retaining Nut and Outer Flange, depress and hold the Shaft Lock pushbutton and loosen

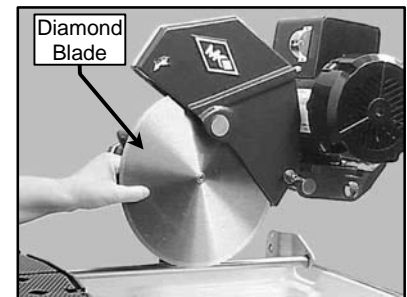

(C)
Remove the Diamond Blade

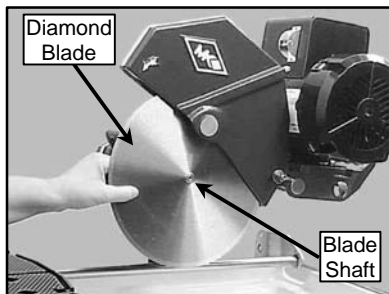

(D)
Install the Diamond Blade onto Blade Shaft

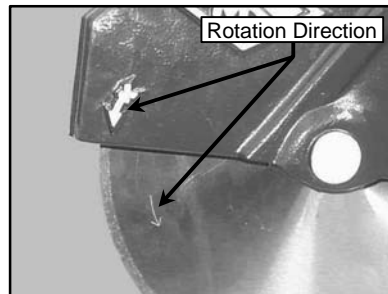

(E)
Verify the Blade is seated on the Blade Shaft and direction of rotation is correct

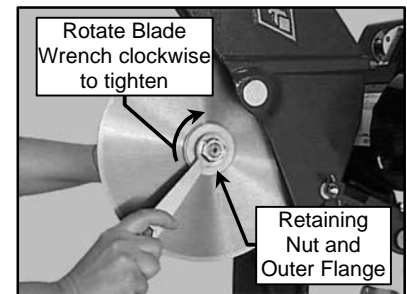

(F)
Install Retaining Nut and Outer Flange, depress and hold the Shaft Lock pushbutton and tighten

MAINTENANCE AND TROUBLESHOOTING

3. V-Belt Inspection, Adjustment and Replacement:

The MK-11 is designed with a power transmission v-belt. In order to ensure the MK-100 operates a peak efficiency, the v-belt should be inspected monthly, and changed if the v-belt shows damage and/or excessive wear.

NOTE: 1. When a new belt is installed, it should be inspected and re-tensioned after the first forty-eight (48) hours of operation.

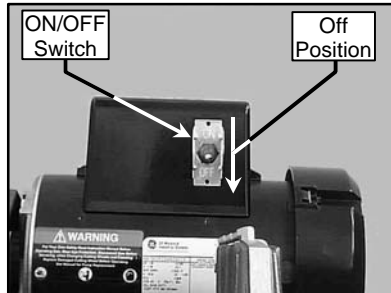

(A)
Ensure the ON/OFF Switch is in the OFF position

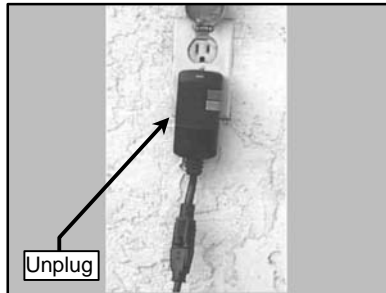

(B)
Unplug the GFCI from the Power source

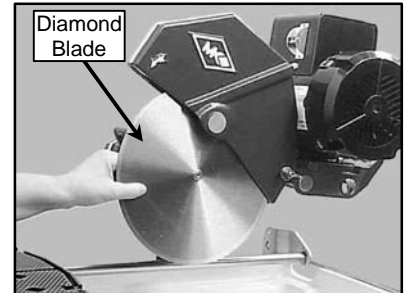

(C)
Remove the Diamond Blade

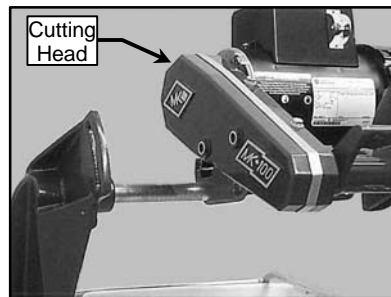

(D)
Remove the Cutting Head (See Adjusting the Cutting Head)

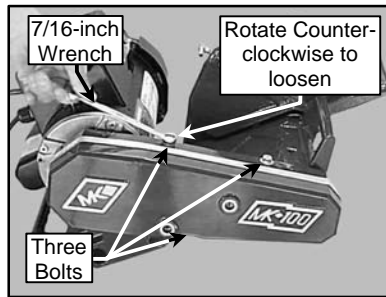

(E)
Remove the Belt Guard

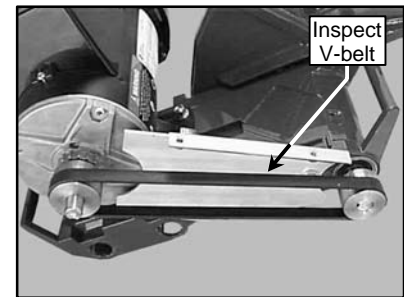

(F)
Inspect the V-belt for cracks, Fraying, separation and wear. Go to step H if replacement required

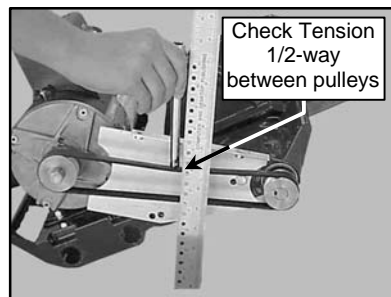

(G)
Check belt for proper tension if tension correct, go to step R (proper tension 1/8-inch)

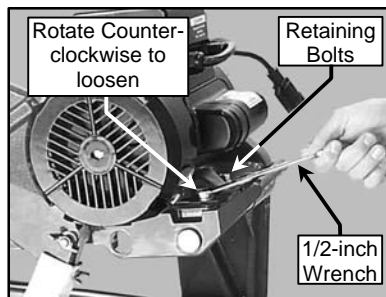

(H)
Loosen motor mounting bolts If re-tensioning only, go to step N

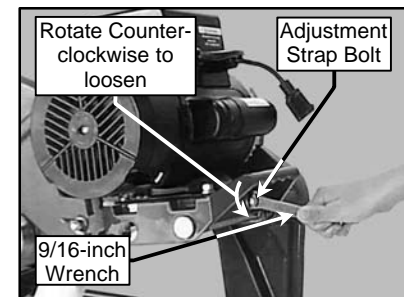

(I)
Loosen the Motor Adjustment Strap

MAINTENANCE AND TROUBLESHOOTING

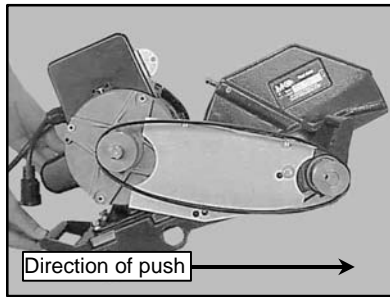

(J)
Push the motor toward the front of the Cutting Head to loosen the V-belt

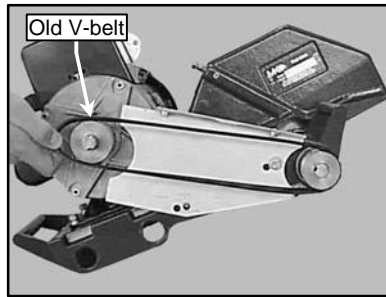

(K)
Remove the V-belt

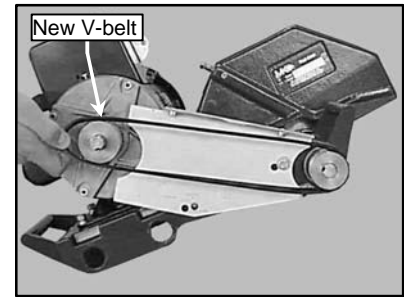

(L)
Install the new V-belt
(MK Diamond Part No. 158194)

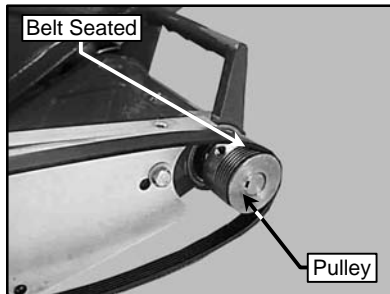

(M)
Verify the V-belt is seated in the grooves of both pulleys

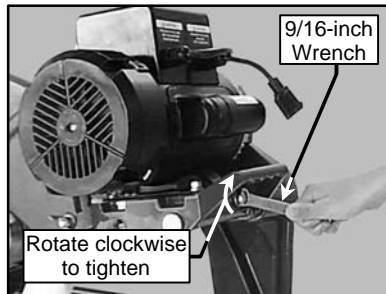

(N)
Tighten the Motor Adjustment Strap to remove slack

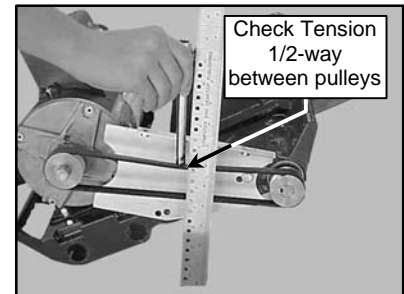

(O)
Check V-belt tension
(proper tension 1/8-inch)

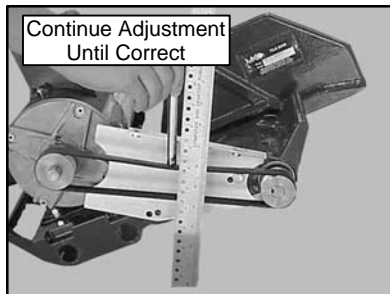

(P)
Repeat steps N and O until proper V-belt tension is achieved

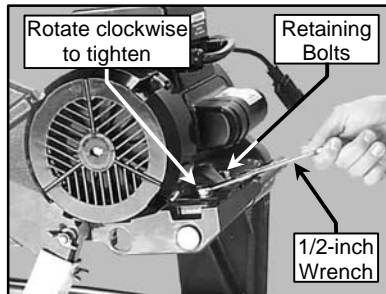

(Q)
Tighten the motor mounting bolts

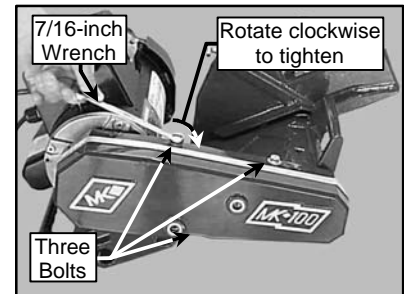

(R)
Install the Belt Guard

MAINTENANCE AND TROUBLESHOOTING

TROUBLESHOOTING:

4. Blade will not cut properly:



(A)
Check for Smoothness
or "Glazing" (Dress blade
if needed)

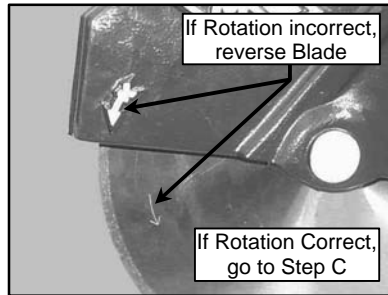

(B)
Check for proper rotation

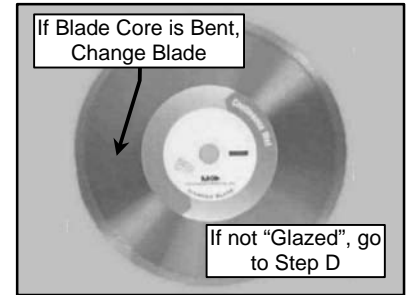

(C)
Ensure the Blade Core
is not bent



(D)
Verify the blade is correct for
the material being used

**Return to
MK Diamond
for Repair**

(E)
Return to MK Diamond

5. Movable Cutting Table Does Not Move Correctly:

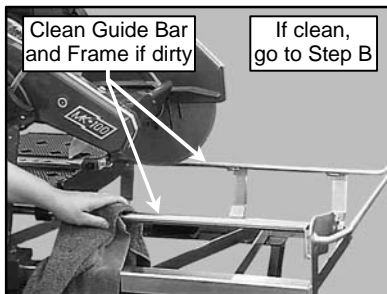

(A)
Check that the Guide Bar
are clean – clean if dirty

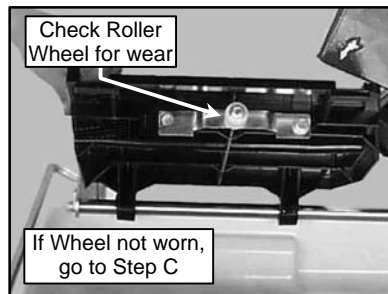

(B)
Check the Movable Cutting Table
Roller Wheels for wear replace
if necessary

**Return to
MK Diamond
for Repair**

(C)
Return to MK Diamond

MAINTENANCE AND TROUBLESHOOTING

6. Cooling Flow:

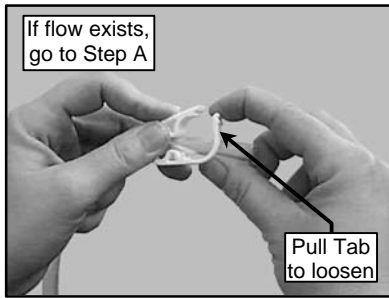

(A)
Check cooling flow
Adjusting Clamp open

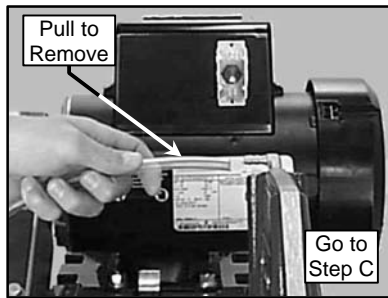

(B)
Remove the Cooling Transfer Tube from the Blade Guard inlet

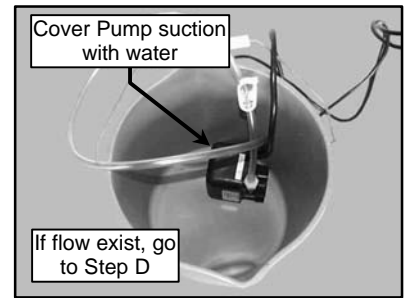

(C)
Place Pump into a bucket of water and check flow

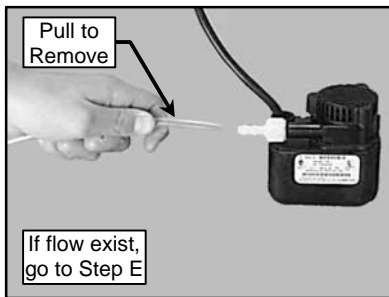

(D)
Remove the Cooling Transfer Tube and check flow

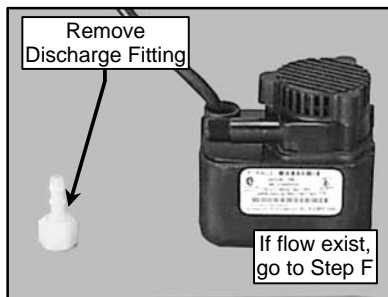

(E)
Remove the Pump Discharge Fitting and check

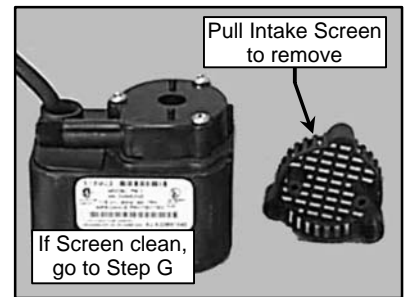

(F)
Remove the Pump Intake Screen and check for debris

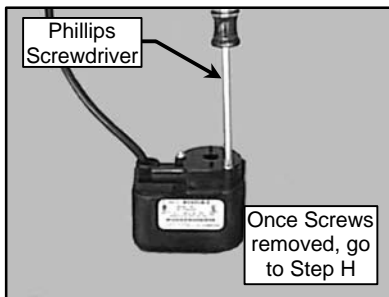

(G)
Remove the 3 Pump Casing Retaining Screws

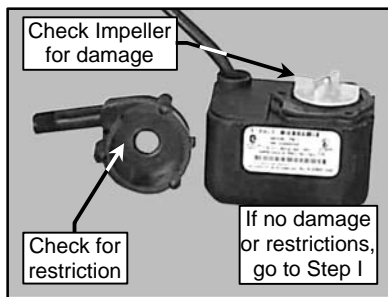

(H)
Remove the Pump Casing and check for restriction; check Impeller damage

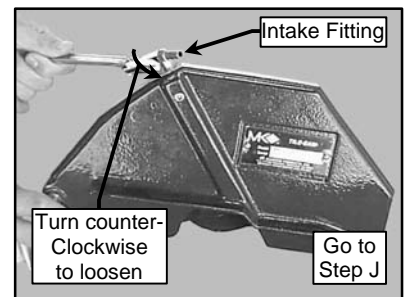

(I)
Remove the Blade Guard Intake Fitting

MAINTENANCE AND TROUBLESHOOTING

NOTE: "Rodding" cooling channels is performed by inserting a small wire rod through the cooling inlet on top of the Blade Guard and directing the rod out through each of the cooling flow tubes located on the underside of the Blade Guard. The cooling channels should be "rodded" until all ports are free of foreign debris.

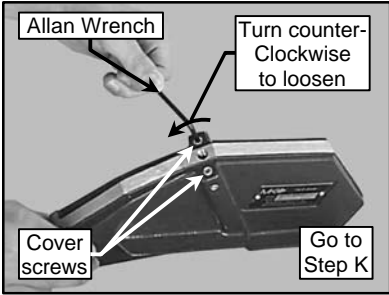

(J)
Remove the Cooling Channel cover screws

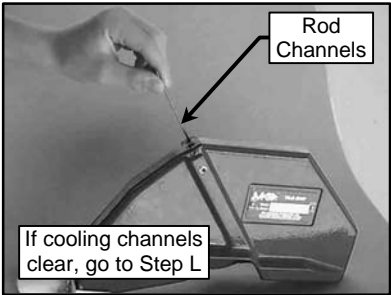

(K)
Rod Cooling Channels and recheck flow

Return to MK Diamond for Repair

(L)
Return to MK Diamond

MAINTENANCE AND TROUBLESHOOTING

7. Blade Stops Turning:

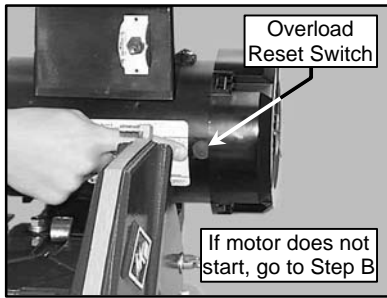

(A)
Allow motor to cool and depress motor Overload Reset Switch

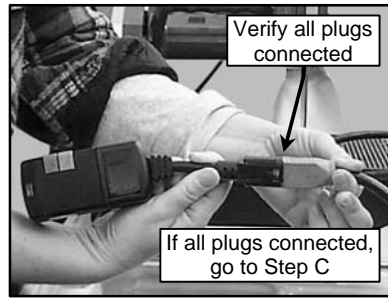

(B)
Verify all plugs fully installed

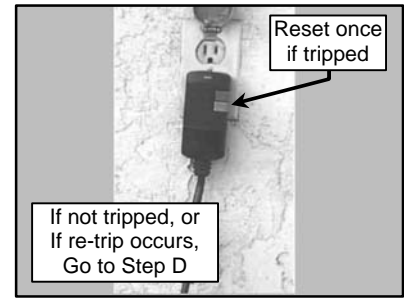

(C)
Check Ground Fault Circuit Interrupter (GFCI) tripped

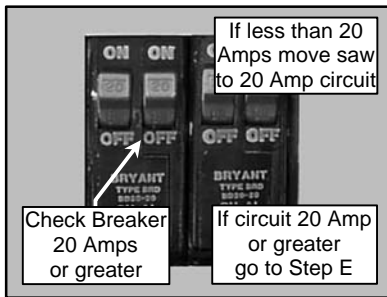

(D)
Verify circuit breaker at least 20 amps – if not, move to 20-amp circuit

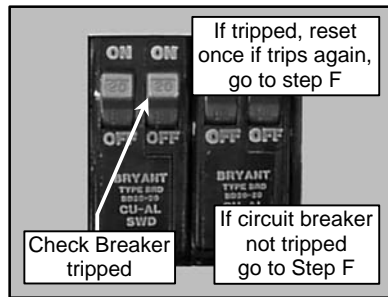

(E)
Verify circuit breaker not tripped
If tripped, reset once

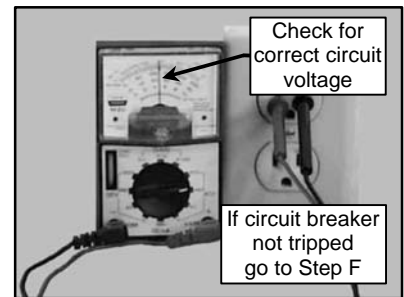

(F)
Check power source voltage is 115V – if not 115v, move to another circuit

**Return to
MK Diamond
for Repair**

(G)
Return to MK Diamond

EXPLODED VIEW AND PARTS LIST

EXPLODED VIEW:

CUTTING HEAD ASSEMBLY (F-J), P/N 158225

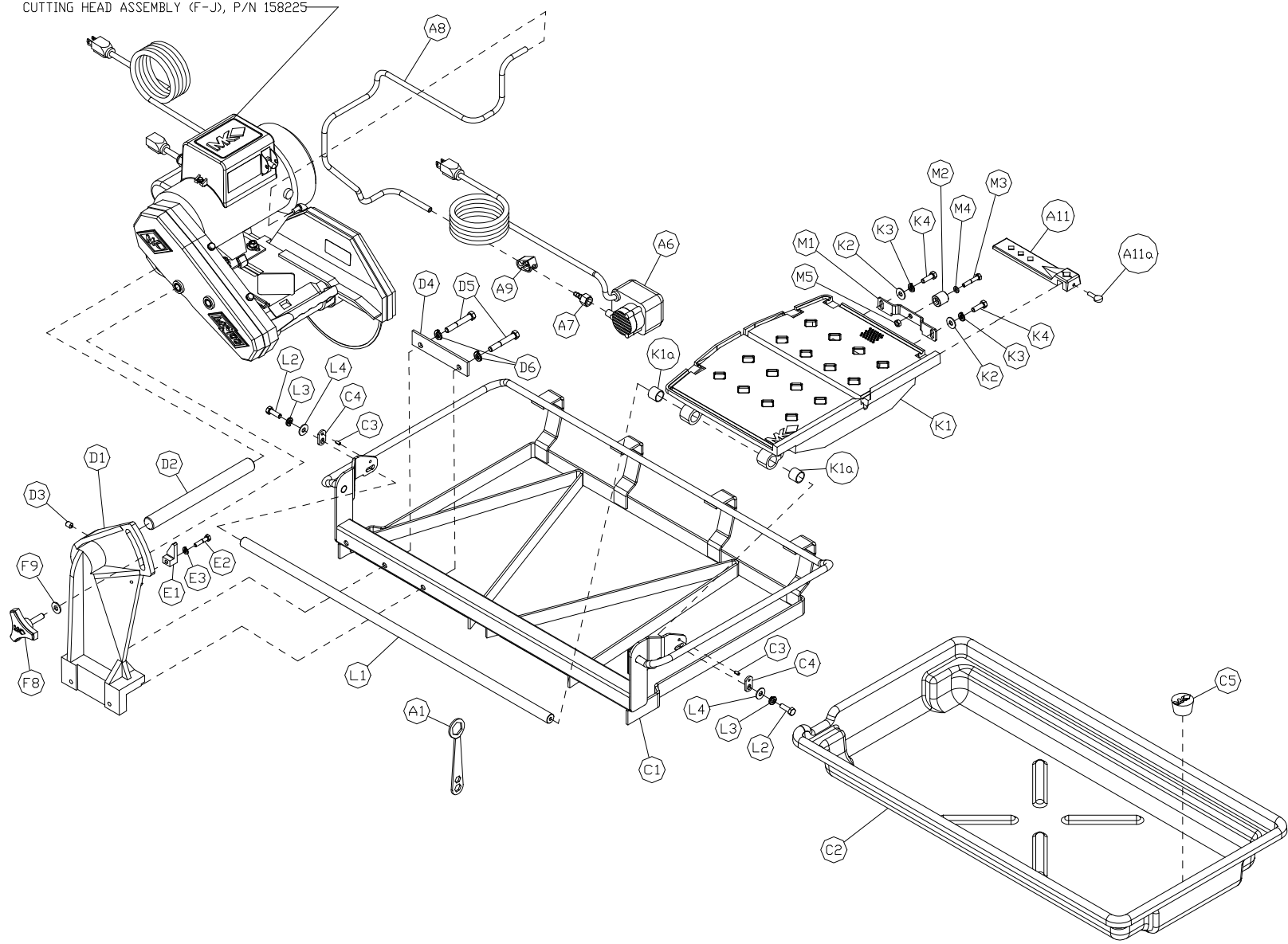

EXPLODED VIEW AND PARTS LIST

PARTS LIST:

Item	Description	Qty	Part #
A Accessory Pack		-	n/a
A1	Wrench, 15/16 Closed End	1	134684
A2	Curtain, Splash	1	134841
A3	Bracket, Splash Curtain	1	152571
A4	Wingscrew, 1/4-20 X 1/2	1	151888
A5	Washer, 1/4 SAE Flat	1	151915
A6	Pump, 115v Water	1	151271
A7	Fitting, Plastic, 1/4 FNPT X 1/4 BARB	1	128397
A8	Hose, Vinyl, 1/4 ID	2'	132951
A9	Clamp, Flow, 1/4-1/2	1	154394
A10	Owner's Manual, Water Pump	1	155745
A11	Rip Guide (comp)	1	134551
A11a	Screw, 1/4-20 X 3/4 Thumb	1	150991
A12	Blade, MK-100, 10 X 060 X 5/8	1	154380
A13	Owner's Manual, MK-100	1	158192
A14	Carton, Accessory Pack, 101	1	153366
A15	Foam, Accessory Pack Carton	1	154022
A16	Card, MK Warranty Registration	1	155037
A17	Label, Do Not Return	1	157063
A18	Sell Sheet, Tile Accessory	1	156915
B Carton		-	n/a
B1	Carton, 101, Plain	1	155306
B2	Insert, Carton, 101	2	151951
B3	Pallet, 101	1	153407
B4	Pad, 6 X 6 X 4 1# EPS Foam	1	154262
C-E Assembly, Frame		-	n/a
C Frame			n/a
C1	Frame, 101	1	153003
C2	Pan, Plastic, 101	1	150634
C3	Pin, 3/16 X 3/8 Roll	2	151783
C4	Plate, Adjustment	2	151758
C5	Plug, Rubber Drain	1	153439
D Post			n/a
D1	Post, 101, MK Red (comp)	1	155670
	Post, MK Red (raw)	1	155669
D2	Shaft, 10.63" Pivot, 101	1	153254
	Steel, 1 Dia C1045 CDS	.92'	156193
D3	Screw, 3/8-16 X 1/2 Socket Head Set	1	153710
D4	Plate, Support	1	155671
D5	Screw, 3/8-16 X 2 1/2	2	156030
D6	Washer, 3/8 Split Lock	2	150925
E1	Stop, 10" Cutting Head	1	157728
E2	Screw, 1/4-20 X 1 1/4 Hex Head Cap	1	157145
E3	Washer, 1/4 Split Lock	1	152591
E4	Sheet, Cutting Head Stop Instruction	1	157728-IS

EXPLODED VIEW AND PARTS LIST

Item	Description	Qty	Part #
F-J	Assembly, 115V Cutting Head, MK-100	1	158225
F	Belt Guard		n/a
F1	Belt Guard, MK-100 (comp)	1	158319-00
	Belt Guard, MK-100 logo (raw)	1	158318-00
	Insert, 3/8-16 AVK	2	158193
F2	Bracket, Inner Belt Guard	1	153260
F3	Screw, ¼20 x 1 Hex Head Cap	3	152370
F4	Screw, ¼20 x 1 Hex Head Cap	1	152676
F5	Washer, ½ Split Lock	4	152591
F6	Washer, ½ SAE Flat	4	151915
F7	Belt, 260J6 Micro-V	1	158194
F8	Knob, 3/8-16 X 1.5 MK Adjustment	1	156770-2
F9	Washer, 3/8 SAE Flat	1	150923
G	Blade Guard	1	n/a
G1	Blade Guard, 101/115 (comp)	1	153659
	Blade Guard, MK logo (raw)	1	152508
G2	Elbow, 1/8 MNPT X ½ BAR B 90° Brass	1	154652
G3	Tube, Water	2	155389
	Tubing, Stainless Steel ½ OD X .028 wall	.75'	152579
G4	Screw, 5/16-18 X ½ Socket Head Set	3	152607
G5	Label, Tilesaw Serial Number	1	157249-01
H	Subassembly, 115V Cutting Head, MK-100	1	158191
H1	Head, 10" Cutting (comp)	1	158224
	Head, 10" Cutting (raw)	1	158223
H2	Pin, Blade Shaft Lock	1	158200
H3	Spring, Blade Guard Lock	1	158201
H4	E-Ring, ½ Retaining	2	158202
H5	Bearing, 17mm X 40mm X 12mm Ball (6203-2NSE)	2	137711
H6	Shaft, Blade 880/101/1080	1	158222
	Steel, Dia C12L14	1'	154188
H7	Flange, 2-3/8 Inner	1	137737
	Steel, 2-3/8 Dia C12L14	.09'	154196
H8	Flange, 2-3/8 Outer	1	135830
H9	Nut, 5/8-18 Hex	1	135848
H10	Pulley, 6J19 X 5/8 Bore	1	158199
	Steel, 2.0 Dia C1215 CD	1.5"	154723
H11	Key, 3/16 x 3/16 x 1 1/8 Square	1	150344
H12	Screw, 5/16-18 X 3/8 Socket Head Set, Cup Point	2	157083
H13	Bumper, Dia Rubber	1	152674
H14	Screw, 5/16-18 X 1 Hex Head Cap	4	151743
H15	Washer, 5/16 SAE Flat	4	151754
H16	Washer, 5/16 Split Lock	4	151747
H17	Nut, 5/16-18 Hex	4	101196
H18	Screw, 5/16-18 X 2 Hex Head Cap, Full Thread	1	151748
H19	Pivot, Blade Guard	1	153208
H20	Washer, 3/8 SAE Flat	2	150923
H21	Wingnut, 5/16-18 Nylock	1	151746
H22	Strap, Motor Adjustment	1	152673
H23	Screw, 3/8-16 X 3 Hex Head Full Thread	1	153147

EXPLODED VIEW AND PARTS LIST

Item	Description	Qty	Part #
J	Assembly, 1.5hp/115V/60Hz GE Motor	1	158297
J1	Motor, 1.5HP\115V\60Hz GE	1	157980
J2	Casting, Conduit Box (comp)	1	157971
	Casting, Conduit Box (raw)	1	158077
J3	Gasket, Conduit Box / Motor	1	158213
J4	Screw, #12 X 5/8 Indented Hex Washer Slotted B	2	158335
J5	Cord, 14/3 SJTW X 5-15P X Power	1	158205
J6	Cord, 18/3 SJTW X 5-15R Pump	1	158253
J7	Switch, 20A DPST Toggle, w/ QD Terminals	1	154310
J8	Plate, Toggle Switch Lockout	1	158211
J9	Boot, Toggle Switch	1	154301
J10	Pulley, 6J17 X 5/8 Bore Steel, 1.75 Dia C1215 CD	1 1.5"	158214 155342
J11	Key, 3/16 x 3/16 x 1-1/8 Square	1	150344
J12	Screw, 5/16-18 X 3/8 Socket Head Set, Cup Point	2	157083
J13	Label, Warning, Read Owner's Manual, 1-3/4 X 3-3/8	1	155806
J14	Label, Caution, GFCI, 1 X 2 1/8	1	155678
J15	Label, Caution, 5 Amp Max., 1 X 2-1/8	1	154822
J16	Label, MK Service Info., 2 1/8 X 1-13/16	1	155038
J17	Screw, 10-32 X 3/8 Hex Washer Head Grounding	1	158209
J18	Washer, #10 Internal Tooth Lock	2	158336
J19	Tie, 12 X #10 Clamp	1	158210
J20	Screw, 10-32 X 1 Socket Head Set, Cup Point	1	158254
J21	Nut, 10-32 Hex	2	156269
J22	Washer, 1/2 Internal Tooth Lock	1	158337
J23	Capacitor, 50mF Run, w/ QD Terminals	1	158242
J24	Capacitor, 270-324mF Start, w/ QD Terminals	1	156206
J25	Switch, Overload Protection	1	156207
K-M	Assembly, Table	-	n/a
K	Table		n/a
K1	Table, 100 (comp)	1	157660
-	Table, 100 (raw)	1	157597
K1a	Bearing, 3/4 ID Multilube	2	152227
K2	Washer, 5/16 SAE Flat	2	151754
K3	Washer, 5/16 Split Lock	2	151747
K4	Screw, 5/16-18 X 1 Hex Head Cap	2	151743
L	Guide Bar		n/a
L1	Bar, 3/4 X 32 Guide, 101 Steel, 3/4 Dia C1045 Chromerod	1 3'	134759 154185
L2	Screw, 5/16-18 X 1 Hex Head Cap	2	151743
L3	Washer, 5/16 Split Lock	2	151747
L4	Washer, 5/16 SAE Flat	2	151754
M	Assembly, Roller Wheel	1	151756
M1	Bracket, Roller Wheel	1	154021
M2	Wheel, Roller	1	151799
M3	Screw, 1/4-20 X 1 1/2 Hex Head Cap	1	151914
M4	Washer, 1/4 SAE Flat	1	151915
M5	Nut, 1/4-20 Hex	1	151893

THEORY

THEORY OF DIAMOND BLADES:

Diamond blades do not really cut; they grind the material through friction. Diamond crystals, often visible at the leading edge and sides of the rim/segment, remove material by scratching out particles of hard, dense materials, or by knocking out larger particles of loosely bonded abrasive material. This process eventually cracks or fractures the diamond particle, breaking it down into smaller pieces. As a result, a diamond blade for cutting soft, abrasive material must have a hard metal matrix composition to resist this erosion long enough for the exposed diamonds to be properly utilized. Conversely, a blade for cutting a hard, non-abrasive material must have a soft bond to ensure that it will erode and expose the diamonds embedded in the matrix. These simple principles are the foundation of “controlled bond erosion”.



Types of Cutting:

There are two basic types of cutting-Dry or Wet. The choice of which type of blade to use depends on:

- The requirements of the job
- The machine/tool utilizing the diamond blade
- The preference of the operator









In the case of DRY cutting, the overwhelming popularity and quantity of hand-held saws and the flexible nature of MK Diamond blades to professionally handle most ceramic, masonry, stone and concrete materials, make the DRY cutting blade a very attractive tool. When using a DRY blade, the user must be aware of distinct operating practices to ensure optimum performance. DRY cutting blades require sufficient airflow about the blade to prevent overheating of the steel core. This is best accomplished by shallow, intermittent cuts of the material with periods of “free-spinning” (for several seconds) between each cut, to maximize the cooling process.

For WET cutting applications, MK has the exact blade to compliment both the material to be cut and the wet cutting machine to be used. During cutting operations, liberal amounts of water act as a coolant to support the cutting effectiveness and longevity of the WET blade. Additionally, using water adds to the overall safety of cutting operations by keeping the dust signature down.

Know All You Can About the Material You Wish to Cut

ACCESSORIES

ACCESSORIES:

ITEM	NUMBER	DESCRIPTION	
1.	137166	MK-200, 10 x 5/8 Arbor	
2.	128074	MK-215, 10 x 5/8 Arbor	
3.	153252	MK-315, 10 x 5/8 Arbor	
4.	134577	Dual 45° Flat Angle Guide	
5.	134585 (small) or 153201 (large)	45° Bullnose Miter	
6.	134569	90° Protractor	
7.	152792	Dressing Stone	
8.	152610	Ground Fault Circuit Interrupter	
9.	151889	Universal Stand	

ORDERING and RETURN INFORMATION

ORDERING INFORMATION:

You may order MK Diamond products through your local MK Diamond distributor or, you may order direct from MK Diamond.

NOTE: There is a \$25.00 minimum order when ordering direct from MK Diamond. All purchases must be made using VISA or MasterCard.

When ordering direct from MK Diamond, please have the following information ready before calling:

- The Model Number of the saw
- The Serial Number of the saw
- Where the saw was purchased and when
- The Part Number for the part(s) being ordered
- The Part Description for the part(s) being ordered

All parts may be ordered by calling toll free to – **800 421-5830** or **310 539-5221** and asking for Customer Service. For technical questions, call – **800 474-5594**.

RETURN MATERIALS POLICY:

To expedite the service relative to the return of a product purchased through MK Diamond, please observe the following:

NOTE: When returning all items, they must have been purchased within the previous twelve (12) months.

- Have the Model Number of the saw
- Have the Serial Number of the saw
- Have the location of where the saw was purchased
- Have the date when the saw was purchased
- Contact Customer Service for approval to return the item(s)
- Obtain a Returned Goods Number (RGA) authorizing the return
- Follow the packaging instructions in the following section
- Ensure your item(s) are prepaid to the destination

For returned items, call toll free to – **800 421-5830** or **310 539-5221** and ask for Customer Service. For technical questions, call – **800 474-5594** or **310 257-2845**.

PACKAGING INSTRUCTIONS:

- Remove the Blade guard and Support Angle Assembly
- Dry the saw before shipping
- When packing, include the following: MK-100, Diamond Blade, Blade guard and Support Angle Assembly and Adjustable Cutting Guide (Other Accessories are not required)
- Package the unit in its original container or one of comparable size (do not ship the unit partially exposed)
- Ensure all parts are secured in the packaging to prevent moving

AUTHORIZED SERVICE CENTERS:

For quicker repair time, you may contact MK Diamond Customer Service, toll free, at – **800 421-5830** or **310 539-5221** for the Authorized Service Center closest to you. For technical questions, call – **800 474-5594**.

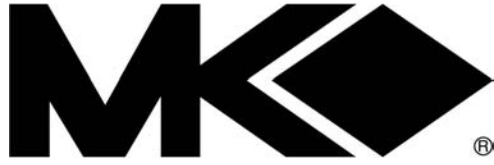

MK-100 SERIES

TILE SAW OWNER'S MANUAL & OPERATING INSTRUCTIONS

CALIFORNIA PROPOSITION 65 MESSAGE:

⚠ WARNING

Some dust created by power sanding, sawing, grinding, drilling, and other construction activities contain chemicals known [to the State of California] to cause cancer, birth defects or other reproductive harm. Some examples of these chemicals are:

- Lead, from lead-based paints
- Crystalline silica, from bricks and cement and other masonry products and
- Arsenic and chromium, from chemically treated lumber

Your risk from these exposures varies depending on how often you do this type of work. To reduce your exposure to these chemicals, work in a well-ventilated area, and work with approved safety equipment, such as those dust masks that are specially designed to filter out microscopic particles.

MK DIAMOND PRODUCTS, INC
1315 STORM PARKWAY, TORRANCE, CA 90509-2803
310 539 5158